

**GigaDevice Semiconductor Inc.**

**GD32F502xx**

**Arm<sup>®</sup> Cortex<sup>®</sup>-M33 32-bit MCU**

**Datasheet**

Revision 0.9RC6

(Mar. 2026)

## Table of Contents

Table of Contents .....	2
List of Figures .....	5
List of Tables .....	7
1. General description .....	9
2. Device overview .....	10
2.1. Device information .....	10
2.2. Block diagram .....	12
2.3. Pinouts and pin assignment.....	13
2.4. Memory map .....	19
2.5. Clock tree.....	23
2.6. Pin definitions .....	24
2.6.1. GD32F502Vx LQFP100 pin definitions .....	24
2.6.2. GD32F502Rx LQFP64 pin definitions .....	31
2.6.3. GD32F502Rx QFN64 pin definitions .....	36
2.6.4. GD32F502Rx BGA64 pin definitions .....	41
2.6.5. GD32F502Cx LQFP48 pin definitions .....	46
2.6.6. GD32F502Cx QFN48 pin definitions .....	50
2.6.7. GD32F502Kx QFN32 pin definitions .....	54
2.6.8. GD32F502xx pin alternate functions .....	57
3. Functional description .....	60
3.1. Arm® Cortex®-M33 core.....	60
3.2. On-chip memory.....	60
3.3. Clock, reset and supply management .....	61
3.4. Boot modes .....	61
3.5. Power saving modes.....	63
3.6. Trigger selection controller (TRIGSEL) .....	63
3.7. General-purpose and alternate-function I/Os (GPIO and AFIO) .....	63
3.8. Direct memory access controller (DMA).....	64
3.9. DMA request multiplexer (DMAMUX) .....	64
3.10. CRC calculation unit (CRC) .....	65
3.11. Analog to digital converter (ADC) .....	65

3.12.	Digital to analog converter (DAC) .....	65
3.13.	Real time clock (RTC) .....	66
3.14.	Timers and PWM generation .....	66
3.15.	Universal synchronous/asynchronous receiver transmitter (USART/UART) ....	67
3.16.	Inter-integrated circuit (I2C) .....	68
3.17.	Controller area network (CAN) .....	68
3.18.	Serial peripheral interface (SPI) .....	69
3.19.	Inter-IC sound (I2S) .....	69
3.20.	Universal serial bus full-speed interface (USBFS).....	69
3.21.	Debug mode .....	70
3.22.	Package and operation temperature.....	70
4.	Electrical characteristics.....	71
4.1.	Parameter introduction.....	71
4.2.	Absolute maximum ratings .....	72
4.3.	General operating conditions.....	73
4.4.	Power supply requirement characteristics.....	74
4.5.	Start-up timings of Operating conditions.....	75
4.6.	Wake-up times from power saving modes .....	76
4.7.	Power consumption .....	76
4.8.	EMC characteristics .....	87
4.9.	Power supply supervisor characteristics.....	88
4.10.	External clock characteristics.....	90
4.11.	Internal clock characteristics .....	94
4.12.	PLL characteristics .....	95
4.13.	Memory characteristics .....	96
4.14.	NRST pin characteristics .....	97
4.15.	GPIO current injection characteristics .....	98
4.16.	GPIO characteristics .....	98
4.17.	Internal reference voltage characteristics.....	101
4.18.	ADC characteristics .....	101
4.19.	Temperature sensor characteristics.....	104
4.20.	DAC characteristics .....	104

4.21.	I2C characteristics .....	106
4.22.	SPI characteristics .....	107
4.23.	I2S characteristics.....	110
4.24.	USART characteristics.....	112
4.25.	CAN characteristics .....	113
4.26.	TIMER characteristics.....	113
4.27.	USBFS characteristics .....	114
4.28.	WDGT characteristics .....	115
4.29.	JTAG Timing.....	116
4.30.	SWD Timing.....	117
5.	Package information.....	119
5.1.	LQFP100 package outline dimensions .....	119
5.2.	LQFP64 package outline dimensions .....	121
5.3.	QFN64 package outline dimensions .....	123
5.4.	BGA64 package outline dimensions.....	125
5.5.	LQFP48 package outline dimensions .....	127
5.6.	QFN48 package outline dimensions .....	129
5.7.	QFN32 package outline dimensions .....	131
5.8.	Thermal characteristics .....	133
6.	Ordering information .....	135
7.	Revision history .....	136

## List of Figures

Figure 2-1. GD32F502xx block diagram .....	12
Figure 2-2. GD32F502Vx LQFP100 pinouts.....	13
Figure 2-3. GD32F502Rx LQFP64 pinouts .....	14
Figure 2-4. GD32F502Rx QFN64 pinouts .....	15
Figure 2-5. GD32F502Rx BGA64 pinouts .....	16
Figure 2-6. GD32F502Cx LQFP48 pinouts .....	17
Figure 2-7. GD32F502Cx QFN48 pinouts .....	17
Figure 2-8. GD32F502Kx QFN32 pinouts .....	18
Figure 2-9. GD32F502xx clock tree.....	23
Figure 4-1. Recommended power supply decoupling capacitors <sup>(1)(2)</sup> .....	74
Figure 4-2. Rise and fall gradient and ripple frequency characteristics .....	75
Figure 4-3. Power consumption measurement diagram .....	77
Figure 4-4. Internal structure diagram of OSCIN and OSCOUT pin .....	90
Figure 4-5. High-speed external clock source AC timing diagram.....	91
Figure 4-6. Low-speed external clock source AC timing diagram.....	93
Figure 4-7. Recommended external OSCIN and OSCOUT pins circuit for crystal .....	93
Figure 4-8. Recommended external OSCIN and OSCOUT pins circuit for oscillator .....	93
Figure 4-9. Recommended external NRST pin circuit <sup>(1)</sup> .....	97
Figure 4-10. Differential linearity error .....	103
Figure 4-11. Integral linearity error .....	103
Figure 4-12. 12-bit buffered /non-buffered DAC .....	106
Figure 4-13. I2C bus timing diagram.....	107
Figure 4-14. SPI timing diagram - master mode .....	108
Figure 4-15. SPI timing diagram - slave mode(CKPH=0) .....	108
Figure 4-16. SPI timing diagram - slave mode(CKPH=1) .....	109
Figure 4-17. I2S timing diagram - master mode .....	111
Figure 4-18. I2S timing diagram - slave mode .....	111
Figure 4-19. USBFS timings: definition of data signal rise and fall time .....	114
Figure 4-20. JTAG timing diagram .....	117
Figure 4-21. SWD timing diagram .....	118
Figure 5-1. LQFP100 package outline .....	119
Figure 5-2. LQFP100 recommended footprint .....	120
Figure 5-3. LQFP64 package outline .....	121
Figure 5-4. LQFP64 recommended footprint .....	122
Figure 5-5. QFN64 package outline .....	123
Figure 5-6. QFN64 recommended footprint .....	124
Figure 5-7. BGA64 package outline .....	125
Figure 5-8. BGA64 recommended footprint.....	126
Figure 5-9. LQFP48 package outline .....	127
Figure 5-10. LQFP48 recommended footprint .....	128
Figure 5-11. QFN48 package outline .....	129

<b>Figure 5-12. QFN48 recommended footprint .....</b>	<b>130</b>
<b>Figure 5-13. QFN32 package outline .....</b>	<b>131</b>
<b>Figure 5-14. QFN32 recommended footprint .....</b>	<b>132</b>

## List of Tables

Table 2-1. GD32F502xx devices features and peripheral list .....	10
Table 2-2. GD32F502xx memory map .....	19
Table 2-3. GD32F502Vx LQFP100 pin definitions .....	24
Table 2-4. GD32F502Rx LQFP64 pin definitions .....	31
Table 2-5. GD32F502Rx QFN64 pin definitions .....	36
Table 2-6. GD32F502Rx BGA64 pin definitions .....	41
Table 2-7. GD32F502Cx LQFP48 pin definitions .....	46
Table 2-8. GD32F502Cx QFN48 pin definitions .....	50
Table 2-9. GD32F502Kx QFN32 pin definitions .....	54
Table 2-10. Port A alternate functions summary .....	57
Table 2-11. Port B alternate functions summary .....	57
Table 2-12. Port C alternate functions summary .....	58
Table 2-13. Port D alternate functions summary .....	58
Table 2-14. Port E alternate functions summary .....	59
Table 2-15. Boot modes .....	62
Table 4-1. Abbreviations .....	71
Table 4-2. Absolute maximum ratings <sup>(1)</sup> .....	72
Table 4-3. General operating conditions <sup>(1)</sup> .....	73
Table 4-4. Power supply requirement characteristics <sup>(1)</sup> .....	74
Table 4-5. Start-up timings of Operating conditions <sup>(1)(2)</sup> .....	75
Table 4-6. Wake-up times from power saving modes <sup>(3)</sup> .....	76
Table 4-7. Power consumption in Run mode <sup>(1)</sup> .....	78
Table 4-8. Power consumption in Run mode with different codes <sup>(1)(2)</sup> .....	80
Table 4-9. Power consumption in Sleep mode <sup>(1)</sup> .....	81
Table 4-10. Power consumption in Deep-sleep mode <sup>(1)</sup> .....	82
Table 4-11. Power consumption in Standby mode .....	84
Table 4-12. Power consumption in BKP_ONLY mode .....	85
Table 4-13. Peripheral current consumption characteristics <sup>(1)</sup> .....	86
Table 4-14. System level ESD and EFT characteristics <sup>(1)</sup> .....	87
Table 4-15. EMI characteristics <sup>(1)</sup> .....	88
Table 4-16. Power supply supervisor characteristics <sup>(1)</sup> .....	88
Table 4-17. High speed external clock (HXTAL) generated from a crystal/ceramic characteristics <sup>(1)</sup> .....	91
Table 4-18. High speed external clock characteristics (HXTAL in bypass mode) <sup>(1)</sup> .....	91
Table 4-19. Low speed external clock (LXTAL) generated from a crystal/ceramic characteristics <sup>(1)</sup> .....	92
Table 4-20. Low speed external user clock characteristics (LXTAL in bypass mode) <sup>(1)</sup> .....	92
Table 4-21. High speed internal clock (IRC48M) characteristics .....	94
Table 4-22. High speed internal clock (IRC8M) characteristics .....	94
Table 4-23. Low speed internal clock (IRC40K) characteristics .....	95
Table 4-24. PLL0 characteristics <sup>(1)</sup> .....	95
Table 4-25. PLL1 characteristics <sup>(1)</sup> .....	96

Table 4-26. Flash memory characteristics <sup>(1)</sup> .....	96
Table 4-27. NRST pin characteristics <sup>(1)</sup> .....	97
Table 4-28. GPIO current injection susceptibility <sup>(1)</sup> .....	98
Table 4-29. I/O static characteristics .....	98
Table 4-30. Output voltage characteristics for all I/Os except PC13, PC14, PC15 <sup>(1)(2)</sup> .....	99
Table 4-31. I/O port AC characteristics <sup>(1)(2)(3)</sup> .....	100
Table 4-32. Internal reference voltage characteristics <sup>(1)</sup> .....	101
Table 4-33. Internal reference voltage calibration values .....	101
Table 4-34. ADC operating conditions <sup>(1)</sup> .....	101
Table 4-35. ADC characteristics <sup>(1)</sup> .....	101
Table 4-36. ADC R <sub>AIN max</sub> for f <sub>ADC</sub> = 42 MHz <sup>(1)</sup> .....	102
Table 4-37. ADC performance characteristics <sup>(1)(2)(3)(4)</sup> .....	102
Table 4-38. Temperature sensor characteristics <sup>(1)</sup> .....	104
Table 4-39. Temperature sensor calibration values .....	104
Table 4-40. DAC characteristics <sup>(1)</sup> .....	104
Table 4-41. DAC characteristics <sup>(1)</sup> .....	105
Table 4-42. DAC performance characteristics .....	105
Table 4-43. I2C characteristics <sup>(1)(2)</sup> .....	106
Table 4-44. Standard SPI characteristics <sup>(1)</sup> .....	107
Table 4-45. I2S characteristics <sup>(1)</sup> .....	110
Table 4-46. USART0 characteristics in Synchronous mode <sup>(1)</sup> .....	112
Table 4-47. USART1/2 characteristics in Synchronous mode <sup>(1)</sup> .....	112
Table 4-48. USART0 characteristics in Smartcard mode <sup>(1)</sup> .....	112
Table 4-49. USART1/2 characteristics in Smartcard mode <sup>(1)</sup> .....	112
Table 4-50. UART3/4 characteristics <sup>(1)</sup> .....	112
Table 4-51. TIMER characteristics <sup>(1)</sup> .....	113
Table 4-52. USBFS start up time <sup>(1)</sup> .....	114
Table 4-53. USBFS DC electrical characteristics <sup>(1)</sup> .....	114
Table 4-54. USBFS full speed-electrical characteristics <sup>(1)</sup> .....	114
Table 4-55. FWDGT min/max timeout period at 40 kHz (IRC40K) <sup>(1)</sup> .....	115
Table 4-56. WWDGT min-max timeout value at 100 MHz (f <sub>PCLK1</sub> ) <sup>(1)</sup> .....	116
Table 4-57. JTAG Scan Interface Timing <sup>(1)</sup> .....	116
Table 4-58. SWD Interface Timing <sup>(1)</sup> .....	117
Table 5-1. LQFP100 package dimensions .....	119
Table 5-2. LQFP64 package dimensions .....	121
Table 5-3. QFN64 package dimensions .....	123
Table 5-4. BGA64 package dimensions .....	125
Table 5-5. LQFP48 package dimensions .....	127
Table 5-6. QFN48 package dimensions .....	129
Table 5-7. QFN32 package dimensions .....	131
Table 5-8. Package thermal characteristics <sup>(1)</sup> .....	133
Table 6-1. Part ordering code for GD32F502xx devices .....	135
Table 7-1. Revision history .....	136

## 1. General description

The GD32F502xx device belongs to the high-performance line of GD32 MCU family. It is a new 32-bit general-purpose microcontroller based on the Arm® Cortex®-M33 core. The Cortex®-M33 processor is a 32-bit processor that possesses low interrupt latency and low-cost debug. The characteristics of integrated and advanced make the Cortex®-M33 processor suitable for market products that require microcontrollers with high performance and low power consumption. The Cortex®-M33 processor is based on the Armv8 architecture and supports a powerful and scalable instruction set including general data processing I/O control tasks, advanced data processing bit field manipulations and DSP.

The GD32F502xx device incorporates the Arm® Cortex®-M33 32-bit processor core operating at 200 MHz frequency with Flash security protection to prevent illegal code/data access. It provides up to 1024 KB main Flash memory, 128KB SRAM memory. An extensive range of enhanced I/Os and peripherals connected to two APB buses. The devices offer three 12-bit ADCs, two 12-bit DAC, five general 16-bit timers, two 16-bit PWM advanced timers, one 32-bit general timer, and two 16-bit basic timers, as well as standard and advanced communication interfaces: up to three SPIs, two I2Ss, two I2Cs, three USARTs and two UARTs, two CANs and a USBFS. Additional peripherals as CRC calculation unit (CRC) and a trigger selection controller (TRIGSEL) are included.

The device operates from a 2.6V to 3.6V power supply and available in –40 to +85 °C temperature range. Three power saving modes provide the flexibility for maximum optimization of power consumption, an especially important consideration in low power applications.

The above features make GD32F502xx devices suitable for a wide range of interconnection and advanced applications, especially in areas such as industrial control, consumer and handheld equipment, embedded modules, human machine interface, security and alarm systems, graphic display, audio player, automotive navigation, drone, IoT and so on.



## 2. Device overview

### 2.1. Device information

Table 2-1. GD32F502xx devices features and peripheral list

Part Number			GD32F502																						
			KBU6	KCU6	KEU6	CCO6	CEO6	CGO6	CBT6	CCT6	CET6	CGT6	RCO6	REO6	RGO6	RBT6	RCT6	RET6	RGT6	RCL6	REL6	RGL6	VCT6	VET6	VGT6
FLASH (KB)	BANK 0	Code area	128	256	256	256	256	192	128	256	256	192	256	256	192	128	256	256	192	256	256	192	256	192	
	BANK 0	Data area	0	0	256	0	256	320	0	0	256	320	0	256	320	0	0	256	320	0	256	320	0	256	320
	BANK 1	Data area	0	0	0	0	0	512	0	0	0	512	0	0	512	0	0	0	512	0	0	512	0	0	512
	Total			128	256	512	256	512	1024	128	256	512	1024	256	512	1024	128	256	512	1024	256	512	1024	256	512
SRAM (KB)			64	64	64	64	64	128	64	64	64	128	64	64	128	64	64	64	128	64	64	128	64	64	128
Timers	General timer (16-bit)		5 <small>(2-4,15-16)</small>	5 <small>(2-4,15-16)</small>	5 <small>(2-4,15-16)</small>	5 <small>(2-4,15-16)</small>	5 <small>(2-4,15-16)</small>	5 <small>(2-4,15-16)</small>	5 <small>(2-4,15-16)</small>	5 <small>(2-4,15-16)</small>	5 <small>(2-4,15-16)</small>	5 <small>(2-4,15-16)</small>	5 <small>(2-4,15-16)</small>	5 <small>(2-4,15-16)</small>	5 <small>(2-4,15-16)</small>	5 <small>(2-4,15-16)</small>	5 <small>(2-4,15-16)</small>	5 <small>(2-4,15-16)</small>	5 <small>(2-4,15-16)</small>	5 <small>(2-4,15-16)</small>	5 <small>(2-4,15-16)</small>	5 <small>(2-4,15-16)</small>	5 <small>(2-4,15-16)</small>	5 <small>(2-4,15-16)</small>	
	General timer (32-bit)		1 <small>(1)</small>	1 <small>(1)</small>	1 <small>(1)</small>	1 <small>(1)</small>	1 <small>(1)</small>	1 <small>(1)</small>	1 <small>(1)</small>	1 <small>(1)</small>	1 <small>(1)</small>	1 <small>(1)</small>	1 <small>(1)</small>	1 <small>(1)</small>	1 <small>(1)</small>	1 <small>(1)</small>	1 <small>(1)</small>	1 <small>(1)</small>	1 <small>(1)</small>	1 <small>(1)</small>	1 <small>(1)</small>	1 <small>(1)</small>	1 <small>(1)</small>	1 <small>(1)</small>	
	Advanced timer(16-bit)		2 <small>(0,7)</small>	2 <small>(0,7)</small>	2 <small>(0,7)</small>	2 <small>(0,7)</small>	2 <small>(0,7)</small>	2 <small>(0,7)</small>	2 <small>(0,7)</small>	2 <small>(0,7)</small>	2 <small>(0,7)</small>	2 <small>(0,7)</small>	2 <small>(0,7)</small>	2 <small>(0,7)</small>	2 <small>(0,7)</small>	2 <small>(0,7)</small>	2 <small>(0,7)</small>	2 <small>(0,7)</small>	2 <small>(0,7)</small>	2 <small>(0,7)</small>	2 <small>(0,7)</small>	2 <small>(0,7)</small>	2 <small>(0,7)</small>	2 <small>(0,7)</small>	
	Basic timer (16-bit)		2 <small>(5,6)</small>	2 <small>(5,6)</small>	2 <small>(5,6)</small>	2 <small>(5,6)</small>	2 <small>(5,6)</small>	2 <small>(5,6)</small>	2 <small>(5,6)</small>	2 <small>(5,6)</small>	2 <small>(5,6)</small>	2 <small>(5,6)</small>	2 <small>(5,6)</small>	2 <small>(5,6)</small>	2 <small>(5,6)</small>	2 <small>(5,6)</small>	2 <small>(5,6)</small>	2 <small>(5,6)</small>	2 <small>(5,6)</small>	2 <small>(5,6)</small>	2 <small>(5,6)</small>	2 <small>(5,6)</small>	2 <small>(5,6)</small>	2 <small>(5,6)</small>	

Part Number		GD32F502																							
		KBU6	KCU6	KEU6	CCO6	CEO6	CGO6	CBT6	CCT6	CET6	CGT6	RCO6	REO6	RG06	RBT6	RCT6	RET6	RGT6	RCL6	REL6	RGL6	VCT6	VET6	VGT6	
	SysTick	1	1	1	1	1	1	1	1	1	1	1	1	1	1	1	1	1	1	1	1	1	1		
	Watchdog	2	2	2	2	2	2	2	2	2	2	2	2	2	2	2	2	2	2	2	2	2	2		
	RTC	3	1	1	1	1	1	1	1	1	1	1	1	1	1	1	1	1	1	1	1	1	1		
Connectivity	USART	2 <small>(0-1)</small>	2 <small>(0-1)</small>	2 <small>(0-1)</small>	3 <small>(0-2)</small>	3 <small>(0-2)</small>	3 <small>(0-2)</small>	3 <small>(0-2)</small>	3 <small>(0-2)</small>	3 <small>(0-2)</small>	3 <small>(0-2)</small>	3 <small>(0-2)</small>	3 <small>(0-2)</small>	3 <small>(0-2)</small>	3 <small>(0-2)</small>	3 <small>(0-2)</small>	3 <small>(0-2)</small>	3 <small>(0-2)</small>	3 <small>(0-2)</small>	3 <small>(0-2)</small>	3 <small>(0-2)</small>	3 <small>(0-2)</small>	3 <small>(0-2)</small>		
	UART	0	0	0	0	0	0	0	0	0	2 <small>(3,4)</small>	2 <small>(3,4)</small>	2 <small>(3,4)</small>	2 <small>(3,4)</small>	2 <small>(3,4)</small>	2 <small>(3,4)</small>	2 <small>(3,4)</small>	2 <small>(3,4)</small>	2 <small>(3,4)</small>	2 <small>(3,4)</small>	2 <small>(3,4)</small>	2 <small>(3,4)</small>	2 <small>(3,4)</small>		
	I2C	1 <small>(0)</small>	1 <small>(0)</small>	1 <small>(0)</small>	2 <small>(0-1)</small>	2 <small>(0-1)</small>	2 <small>(0-1)</small>	2 <small>(0-1)</small>	2 <small>(0-1)</small>	2 <small>(0-1)</small>	2 <small>(0-1)</small>	2 <small>(0-1)</small>	2 <small>(0-1)</small>	2 <small>(0-1)</small>	2 <small>(0-1)</small>	2 <small>(0-1)</small>	2 <small>(0-1)</small>	2 <small>(0-1)</small>	2 <small>(0-1)</small>	2 <small>(0-1)</small>	2 <small>(0-1)</small>	2 <small>(0-1)</small>	2 <small>(0-1)</small>	2 <small>(0-1)</small>	
	SPI/I2S	2/1 <small>(0,2)/(2)</small>	2/1 <small>(0,2)/(2)</small>	2/1 <small>(0,2)/(2)</small>	3/2 <small>(0,2)/(1-2)</small>	3/2 <small>(0,2)/(1-2)</small>	3/2 <small>(0,2)/(1-2)</small>	3/2 <small>(0,2)/(1-2)</small>	3/2 <small>(0,2)/(1-2)</small>	3/2 <small>(0,2)/(1-2)</small>	3/2 <small>(0,2)/(1-2)</small>	3/2 <small>(0,2)/(1-2)</small>	3/2 <small>(0,2)/(1-2)</small>	3/2 <small>(0,2)/(1-2)</small>	3/2 <small>(0,2)/(1-2)</small>	3/2 <small>(0,2)/(1-2)</small>	3/2 <small>(0,2)/(1-2)</small>	3/2 <small>(0,2)/(1-2)</small>	3/2 <small>(0,2)/(1-2)</small>	3/2 <small>(0,2)/(1-2)</small>	3/2 <small>(0,2)/(1-2)</small>	3/2 <small>(0,2)/(1-2)</small>	3/2 <small>(0,2)/(1-2)</small>	3/2 <small>(0,2)/(1-2)</small>	
	CAN	2	2	2	2	2	2	2	2	2	2	2	2	2	2	2	2	2	2	2	2	2	2	2	
	USBFS	1	1	1	1	1	1	1	1	1	1	1	1	1	1	1	1	1	1	1	1	1	1	1	
	GPIO		26	26	26	41	41	41	37	37	37	37	56	56	56	51	51	51	51	51	51	51	80	80	80
5VT GPIO		13	13	13	24	24	24	21	21	21	21	34	34	34	29	29	29	29	29	29	29	60	60	60	
TRIGSEL		1	1	1	1	1	1	1	1	1	1	1	1	1	1	1	1	1	1	1	1	1	1	1	
CRC		1	1	1	1	1	1	1	1	1	1	1	1	1	1	1	1	1	1	1	1	1	1	1	
12bit	Units	3	3	3	3	3	3	3	3	3	3	3	3	3	3	3	3	3	3	3	3	3	3	3	
	Channels	10	10	10	14	14	14	12	12	12	12	19	19	19	18	18	18	18	18	18	18	25	25	25	
DAC	Units	1	1	1	1	1	1	1	1	1	1	1	1	1	1	1	1	1	1	1	1	1	1	1	
	Channels	1	1	1	1	1	1	1	1	1	1	1	1	1	1	1	1	1	1	1	1	1	1	1	
Package		QFN32			QFN48			LQFP48				QFN64			LQFP64				BGA64			LQFP100			

## 2.2. Block diagram

Figure 2-1. GD32F502xx block diagram

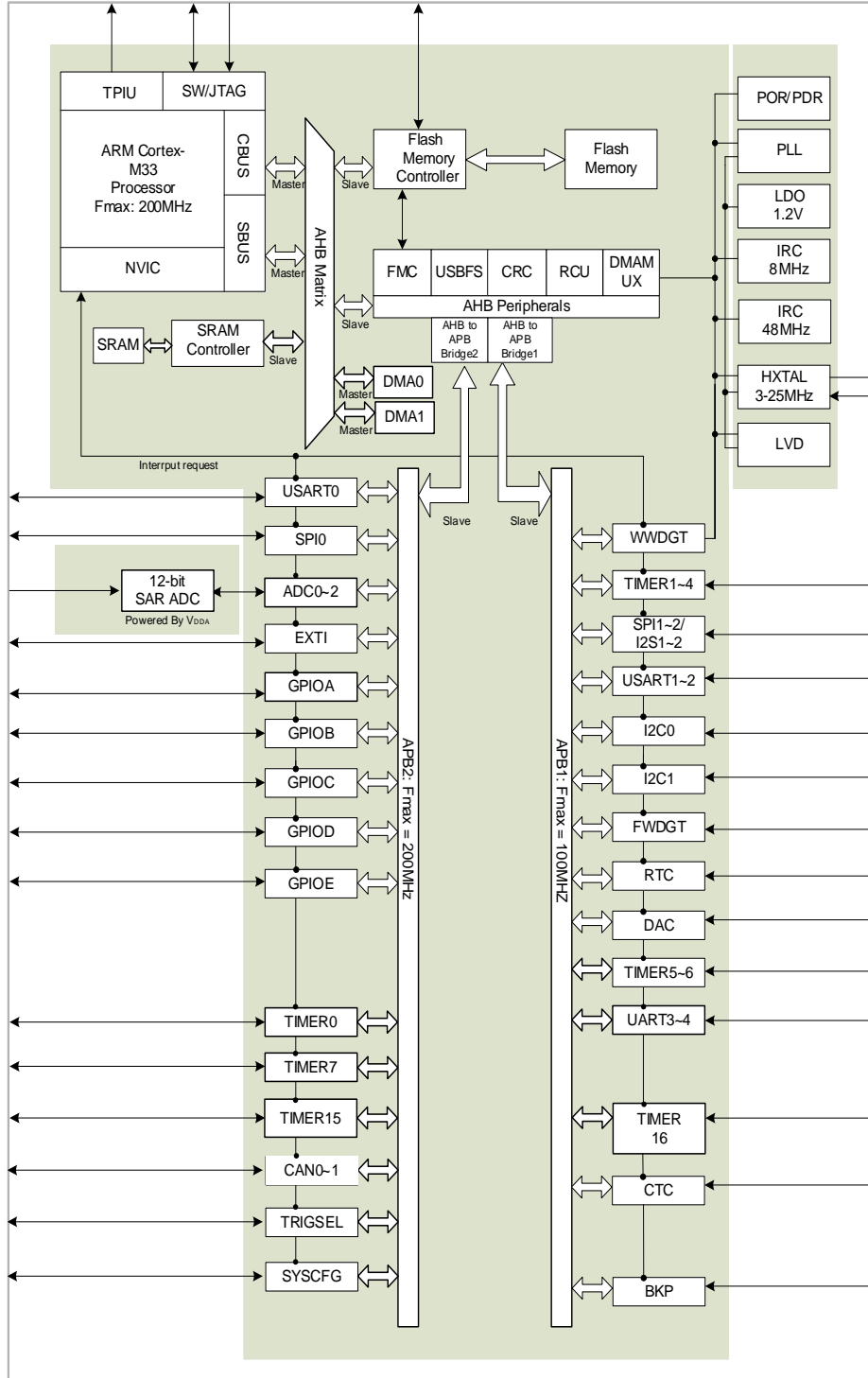

### 2.3. Pinouts and pin assignment

Figure 2-2. GD32F502Vx LQFP100 pinouts

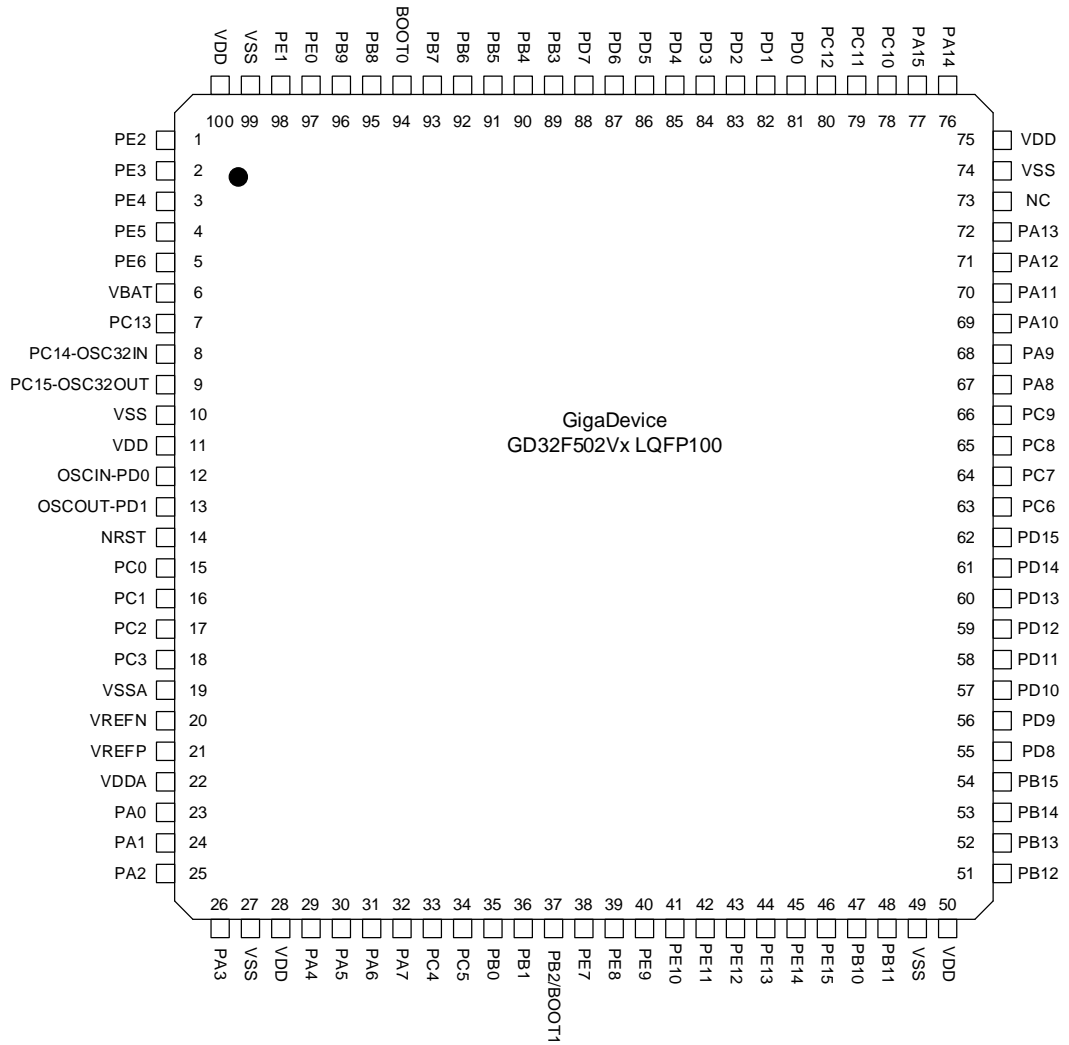

Figure 2-3. GD32F502Rx LQFP64 pinouts

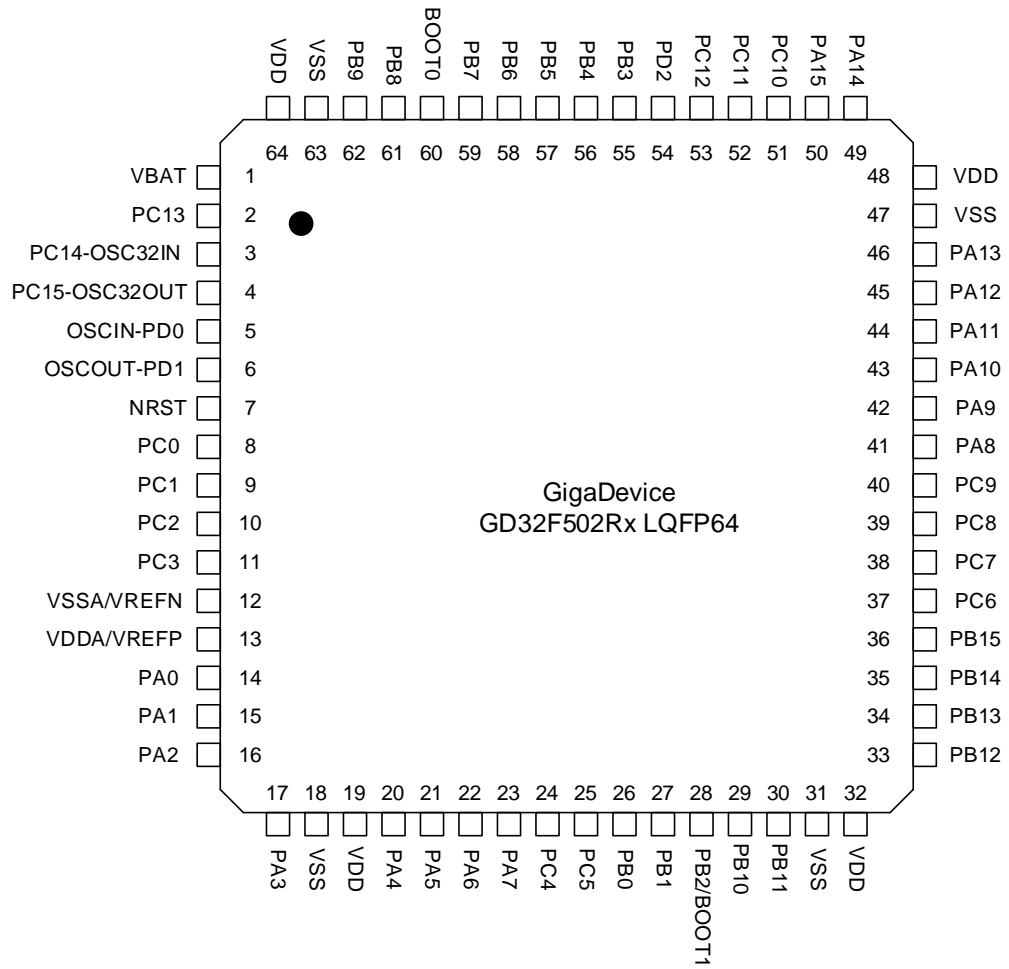

Figure 2-4. GD32F502Rx QFN64 pinouts

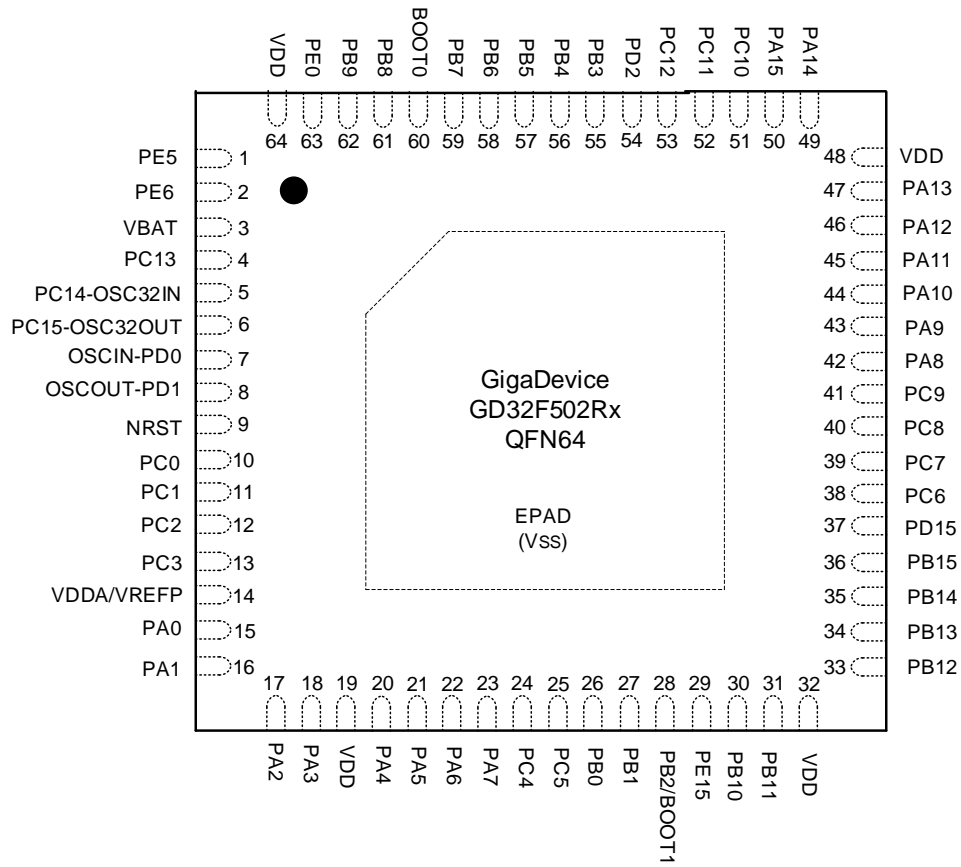

Figure 2-5. GD32F502Rx BGA64 pinouts

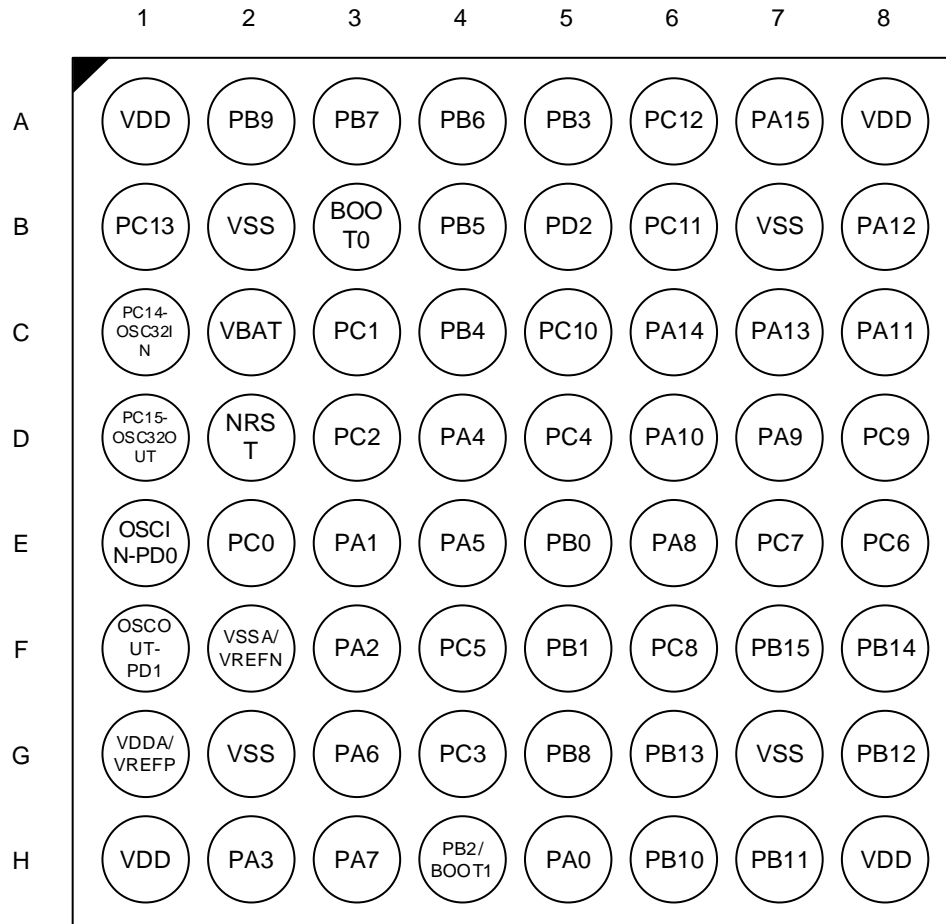

Figure 2-6. GD32F502Cx LQFP48 pinouts

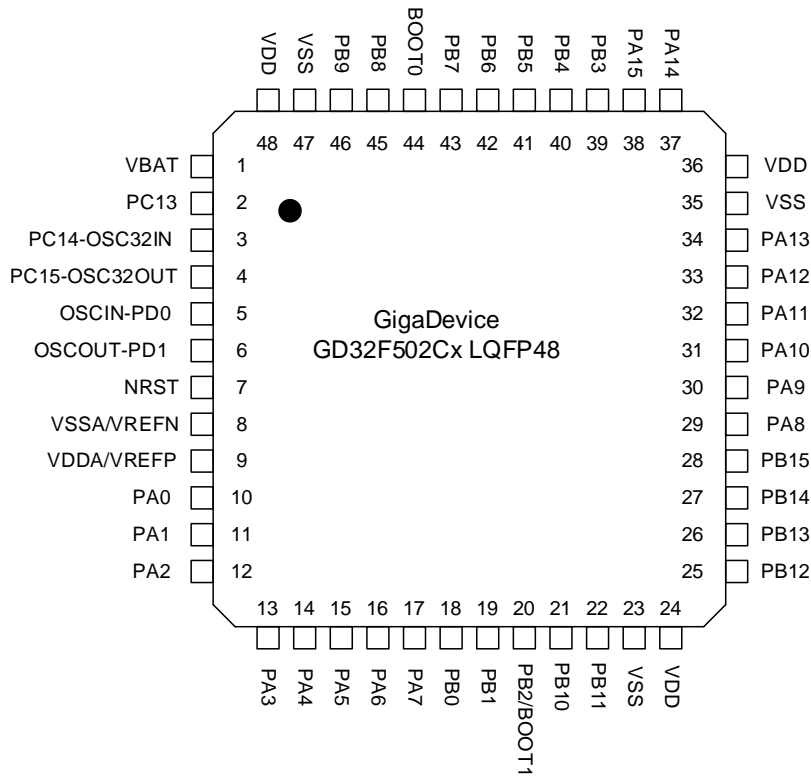

Figure 2-7. GD32F502Cx QFN48 pinouts

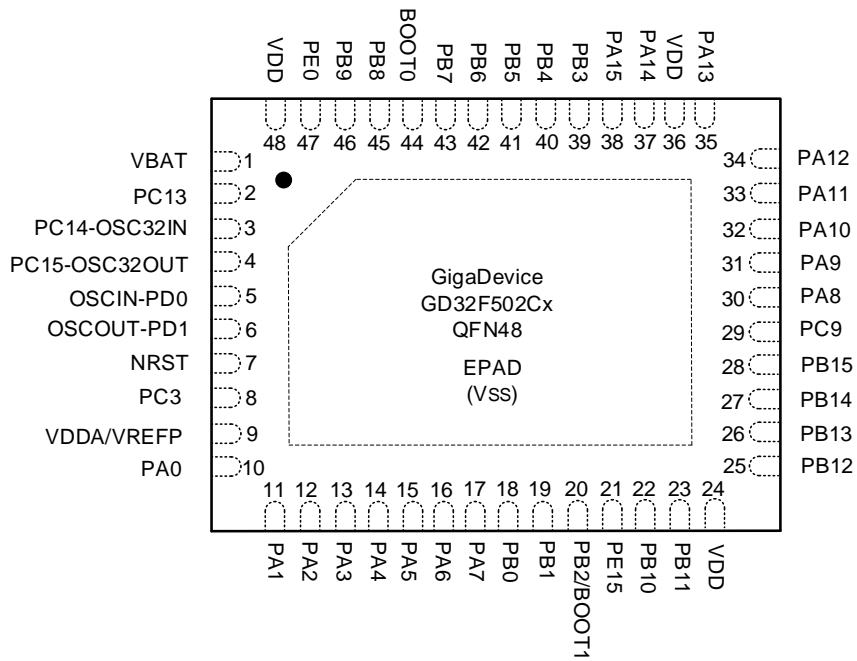
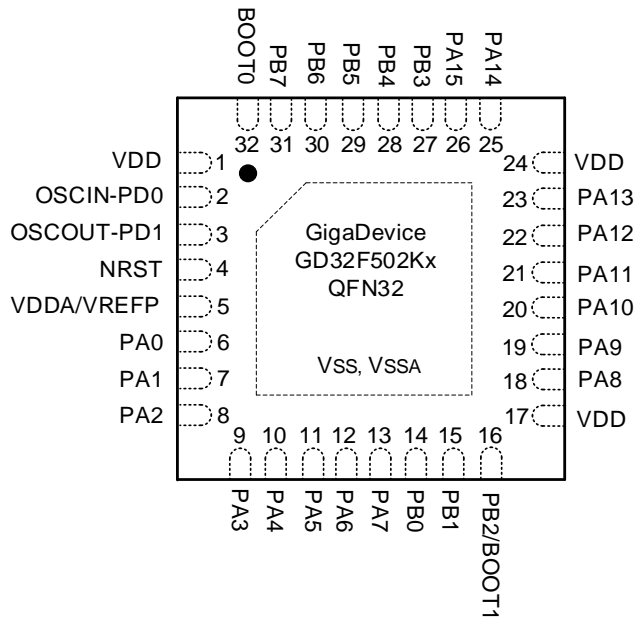

Figure 2-8. GD32F502Kx QFN32 pinouts



## 2.4. Memory map

**Table 2-2. GD32F502xx memory map**

Pre-defined Regions	Bus	Address	Peripherals
Peripheral	AHB1	0x5000 0000 - 0x5003 FFFF	USBFS
		0x4008 0000 - 0x4FFF FFFF	Reserved
		0x4004 0000 - 0x4007 FFFF	Reserved
		0x4002 BC00 - 0x4003 FFFF	Reserved
		0x4002 B000 - 0x4002 BBFF	Reserved
		0x4002 A000 - 0x4002 AFFF	Reserved
		0x4002 8000 - 0x4002 9FFF	Reserved
		0x4002 6800 - 0x4002 7FFF	Reserved
		0x4002 6400 - 0x4002 67FF	Reserved
		0x4002 6000 - 0x4002 63FF	Reserved
		0x4002 5000 - 0x4002 5FFF	Reserved
		0x4002 4000 - 0x4002 4FFF	Reserved
		0x4002 3C00 - 0x4002 3FFF	Reserved
		0x4002 3800 - 0x4002 3BFF	Reserved
		0x4002 3400 - 0x4002 37FF	Reserved
		0x4002 3000 - 0x4002 33FF	CRC
		0x4002 2C00 - 0x4002 2FFF	Reserved
		0x4002 2800 - 0x4002 2BFF	Reserved
		0x4002 2400 - 0x4002 27FF	Reserved
		0x4002 2000 - 0x4002 23FF	FMC
		0x4002 1C00 - 0x4002 1FFF	Reserved
		0x4002 1800 - 0x4002 1BFF	Reserved
		0x4002 1400 - 0x4002 17FF	Reserved
		0x4002 1000 - 0x4002 13FF	RCU
		0x4002 0C00 - 0x4002 0FFF	Reserved
		0x4002 0800 - 0x4002 0BFF	DMAMUX
		0x4002 0400 - 0x4002 07FF	DMA1
		0x4002 0000 - 0x4002 03FF	DMA0
		0x4001 8400 - 0x4001 FFFF	Reserved
		0x4001 8000 - 0x4001 83FF	Reserved
	APB2	0x4001 7C00 - 0x4001 7FFF	Reserved
		0x4001 7800 - 0x4001 7BFF	Reserved
		0x4001 7400 - 0x4001 77FF	Reserved
0x4001 7000 - 0x4001 73FF		Reserved	
0x4001 6C00 - 0x4001 6FFF		Reserved	
0x4001 6800 - 0x4001 6BFF		Reserved	
0x4001 6500 - 0x4001 67FF		Reserved	

Pre-defined Regions	Bus	Address	Peripherals
		0x4001 6400 - 0x4001 64FF	Shared CAN/APB SRAM1
		0x4001 6000 - 0x4001 63FF	Shared CAN/APB SRAM0
		0x4001 5C00 - 0x4001 5FFF	CAN1
		0x4001 5800 - 0x4001 5BFF	CAN0
		0x4001 5400 - 0x4001 57FF	Reserved
		0x4001 5000 - 0x4001 53FF	TIMER15
		0x4001 4C00 - 0x4001 4FFF	Reserved
		0x4001 4800 - 0x4001 4BFF	Reserved
		0x4001 4400 - 0x4001 47FF	TRIGSEL
		0x4001 4000 - 0x4001 43FF	SYSCFG
		0x4001 3C00 - 0x4001 3FFF	ADC2
		0x4001 3800 - 0x4001 3BFF	USART0
		0x4001 3400 - 0x4001 37FF	TIMER7
		0x4001 3000 - 0x4001 33FF	SPI0
		0x4001 2C00 - 0x4001 2FFF	TIMER0
		0x4001 2800 - 0x4001 2BFF	ADC1
		0x4001 2400 - 0x4001 27FF	ADC0
		0x4001 2000 - 0x4001 23FF	Reserved
		0x4001 1C00 - 0x4001 1FFF	Reserved
		0x4001 1800 - 0x4001 1BFF	GPIOE
		0x4001 1400 - 0x4001 17FF	GPIOD
		0x4001 1000 - 0x4001 13FF	GPIOC
		0x4001 0C00 - 0x4001 0FFF	GPIOB
		0x4001 0800 - 0x4001 0BFF	GPIOA
	0x4001 0400 - 0x4001 07FF	EXTI	
	0x4001 0000 - 0x4001 03FF	AFIO	
	APB1	0x4000 CC00 - 0x4000 FFFF	Reserved
		0x4000 C800 - 0x4000 CBFF	CTC
		0x4000 C400 - 0x4000 C7FF	Reserved
		0x4000 C000 - 0x4000 C3FF	Reserved
		0x4000 8000 - 0x4000 BFFF	Reserved
		0x4000 7C00 - 0x4000 7FFF	Reserved
0x4000 7800 - 0x4000 7BFF		Reserved	
0x4000 7400 - 0x4000 77FF		DAC	
0x4000 7000 - 0x4000 73FF		PMU	
0x4000 6C00 - 0x4000 6FFF		BKP	
0x4000 6800 - 0x4000 6BFF		Reserved	
0x4000 6400 - 0x4000 67FF		Reserved	
0x4000 6000 - 0x4000 63FF	Reserved		

Pre-defined Regions	Bus	Address	Peripherals
		0x4000 5C00 - 0x4000 5FFF	Reserved
		0x4000 5800 - 0x4000 5BFF	I2C1
		0x4000 5400 - 0x4000 57FF	I2C0
		0x4000 5000 - 0x4000 53FF	UART4
		0x4000 4C00 - 0x4000 4FFF	UART3
		0x4000 4800 - 0x4000 4BFF	USART2
		0x4000 4400 - 0x4000 47FF	USART1
		0x4000 4000 - 0x4000 43FF	Reserved
		0x4000 3C00 - 0x4000 3FFF	SPI2/I2S2
		0x4000 3800 - 0x4000 3BFF	SPI1/I2S1
		0x4000 3400 - 0x4000 37FF	Reserved
		0x4000 3000 - 0x4000 33FF	FWDGT
		0x4000 2C00 - 0x4000 2FFF	WWDGT
		0x4000 2800 - 0x4000 2BFF	RTC
		0x4000 2400 - 0x4000 27FF	Reserved
		0x4000 2000 - 0x4000 23FF	Reserved
		0x4000 1C00 - 0x4000 1FFF	Reserved
		0x4000 1800 - 0x4000 1BFF	TIMER16
		0x4000 1400 - 0x4000 17FF	TIMER6
		0x4000 1000 - 0x4000 13FF	TIMER5
		0x4000 0C00 - 0x4000 0FFF	TIMER4
		0x4000 0800 - 0x4000 0BFF	TIMER3
		0x4000 0400 - 0x4000 07FF	TIMER2
0x4000 0000 - 0x4000 03FF	TIMER1		
SRAM	AHB	0x2007 0000 - 0x3FFF FFFF	Reserved
		0x2006 0000 - 0x2006 FFFF	Reserved
		0x2003 0000 - 0x2005 FFFF	Reserved
		0x2000 0000 - 0x2002 FFFF	SRAM
Code	AHB	0x1FFF F810 - 0x1FFF FFFF	Reserved
		0x1FFF F800 - 0x1FFF F80F	Option Bytes
		0x1FFF B000 - 0x1FFF F7FF	Boot loader
		0x1FFF 7A10 - 0x1FFF AFFF	Reserved
		0x1FFF 7940 - 0x1FFF 7A0F	Reserved
		0x1FFF 7930 - 0x1FFF 793F	OTP3(lock area)
		0x1FFF 7900 - 0x1FFF 792F	OTP3(data area)
		0x1FFF 7880 - 0x1FFF 788F	Reserved
		0x1FFF 7840 - 0x1FFF 787F	OTP0(lock area)
		0x1FFF 7800 - 0x1FFF 783F	OTP0(data area)

Pre-defined Regions	Bus	Address	Peripherals
		0x1FFF 0000 - 0x1FFF 77FF	Reserved
		0x1FFE C010 - 0x1FFE FFFF	Reserved
		0x1FFE C000 - 0x1FFE C00F	Reserved
		0x1FF2 0190 - 0x1FFE BFFF	Reserved
		0x1FF2 0110 - 0x1FF2 018F	OTP2 (lock area)
		0x1FF2 0100 - 0x1FF2 010F	OTP1 (lock area)
		0x1FF2 0000 - 0x1FF2 00FF	OTP2 (data area)
		0x1FF0 0000 - 0x1FF1 FFFF	OTP1 (data area)
		0x1001 0000 - 0x1FEF FFFF	Reserved
		0x1000 0000 - 0x1000 FFFF	Reserved
		0x083C 0000 - 0x0FFF FFFF	Reserved
		0x0830 0000 - 0x083B FFFF	Reserved
		0x0810 0000 - 0x082F FFFF	Reserved
		0x0800 0000 - 0x080F FFFF	Main Flash
		0x0030 0000 - 0x07FF FFFF	Reserved
		0x0010 0000 - 0x002F FFFF	Aliased to Main Flash or Boot loader
		0x0002 0000 - 0x000F FFFF	
		0x0000 0000 - 0x0001 FFFF	

## 2.5. Clock tree

Figure 2-9. GD32F502xx clock tree

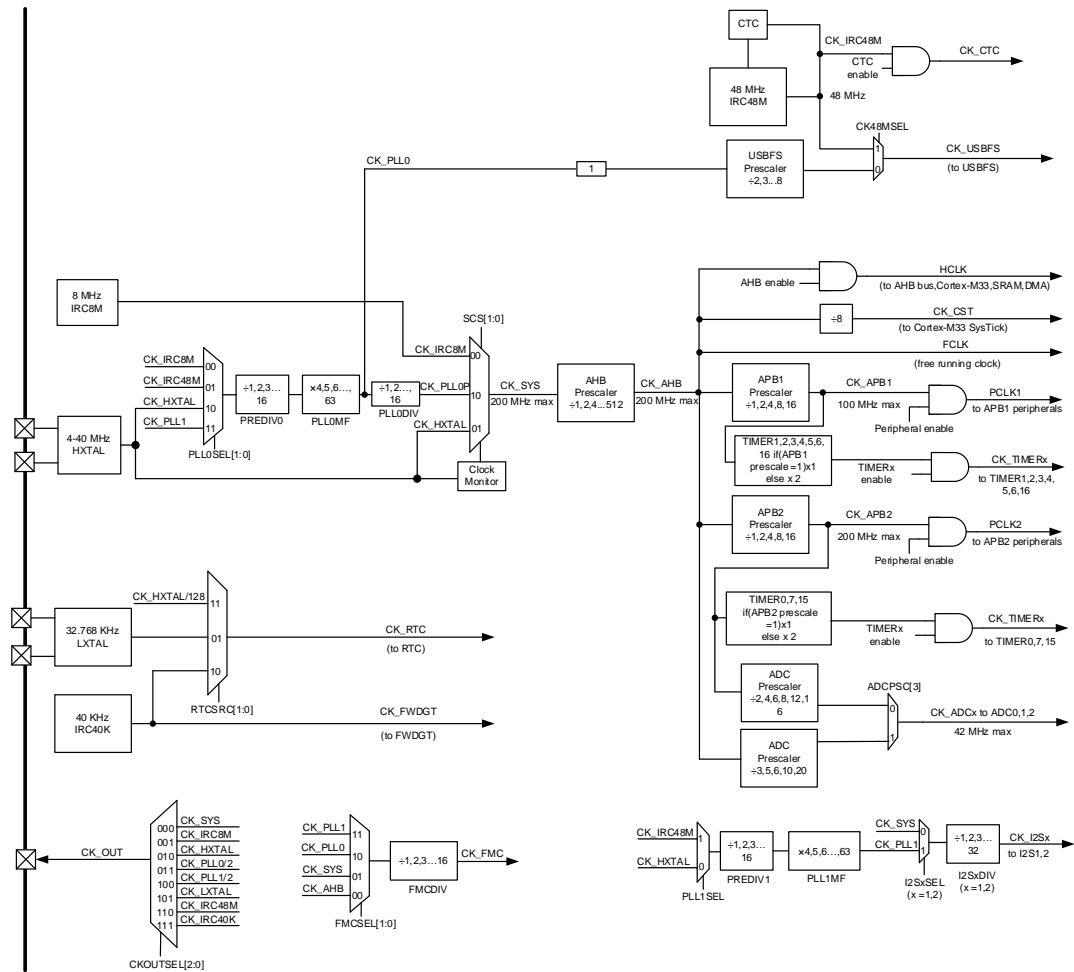

### Legend:

- HXTAL: High speed crystal oscillator
- LXTAL: Low speed crystal oscillator
- IRC8M: Internal 8M RC oscillators
- IRC40K: Internal 40K RC oscillator
- IRC48M: Internal 48M RC oscillators

## 2.6. Pin definitions

### 2.6.1. GD32F502Vx LQFP100 pin definitions

**Table 2-3. GD32F502Vx LQFP100 pin definitions**

GD32F502Vx LQFP100				
Pin Name	Pins	Pin Type <sup>(1)</sup>	I/O Level <sup>(2)</sup>	Functions description
PE2	1	I/O	5VT	Default: PE2 Alternate: EVENTOUT
PE3	2	I/O	5VT	Default: PE3 Alternate: TIMER15_BRKIN, EVENTOUT
PE4	3	I/O	5VT	Default: PE4 Alternate: TIMER15_MCH0, EVENTOUT
PE5	4	I/O	5VT	Default: PE5 Alternate, TIMER15_CH0, EVENTOUT
PE6	5	I/O	5VT	Default: PE6 Alternate: TIMER15_CH1, EVENTOUT
VBAT	6	P	-	Default: VBAT
PC13	7	I/O	-	Default: PC13 Alternate: EVENTOUT Additional: TAMPER-RTC
PC14- OSC32IN	8	I/O	-	Default: PC14, OSC32IN Alternate: EVENTOUT Additional: OSC32IN
PC15- OSC32OUT	9	I/O	-	Default: PC15, OSC32OUT Alternate: EVENTOUT Additional: OSC32OUT
VSS	10	P	-	Default: VSS
VDD	11	P	-	Default: VDD
OSCIN-PD0	12	I/O	-	Default: OSCIN, PD0 Alternate: EVENTOUT Additional: OSCIN
OSCOU- PD1	13	I/O	-	Default: OSCOUT, PD1 Alternate: EVENTOUT Additional: OSCOUT
NRST	14	-	-	Default: NRST
PC0	15	I/O	-	Default: PC0 Alternate: TIMER7_CH0_ON, EVENTOUT Additional: ADC012_IN10
PC1	16	I/O	-	Default: PC1 Alternate: TIMER7_CH1_ON, EVENTOUT Additional: ADC012_IN11
PC2	17	I/O	-	Default: PC2 Alternate: TIMER7_CH2_ON, EVENTOUT Additional: ADC012_IN12

GD32F502Vx LQFP100				
Pin Name	Pins	Pin Type <sup>(1)</sup>	I/O Level <sup>(2)</sup>	Functions description
PC3	18	I/O	-	Default: PC3 Alternate: TIMER7_CH3_ON, EVENTOUT Additional: ADC012_IN13
VSSA	19	P	-	Default: VSSA
VREFN	20	P	-	Default: VREFN
VREFP	21	P	-	Default: VREFP
VDDA	22	P	-	Default: VDDA
PA0	23	I/O	-	Default: PA0 Alternate: USART1_CTS, TIMER1_CH0, TIMER1_ETI, TIMER16_BRKIN, TIMER4_CH0, TIMER7_ETI, TRGSEL_IN5, EVENTOUT Additional: ADC012_IN0, WKUP
PA1	24	I/O	-	Default: PA1 Alternate: USART1_RTS, TIMER1_CH1, TIMER16_MCH0, TIMER4_CH1, TRGSEL_IN6, EVENTOUT Additional: ADC012_IN1
PA2	25	I/O	-	Default: PA2 Alternate: USART1_TX, TIMER1_CH2, TIMER16_CH0, TIMER4_CH2, SPI0_IO2, TRGSEL_OUT0, EVENTOUT Additional: ADC012_IN2
PA3	26	I/O	-	Default: PA3 Alternate: USART1_RX, TIMER1_CH3, TIMER16_CH1, TIMER4_CH3, TIMER0_CH3_ON, SPI0_IO3, TRGSEL_OUT1, EVENTOUT Additional: ADC012_IN3
VSS	27	P	-	Default: VSS
VDD	28	P	-	Default: VDD
PA4	29	I/O	-	Default: PA4 Alternate: SPI0_NSS, USART1_CK, SPI2_NSS, I2S2_WS, TIMER15_BRKIN, TIMER7_CH1BRKIN, EVENTOUT Additional: ADC01_IN4, DAC0_OUT0
PA5	30	I/O	-	Default: PA5 Alternate: SPI0_SCK, TIMER4_ETI, TIMER15_MCH0, TIMER7_CH0BRKIN, EVENTOUT Additional: ADC01_IN5, DAC0_OUT0
PA6	31	I/O	-	Default: PA6 Alternate: SPI0_MISO, TIMER2_CH0, TIMER0_BRKIN, TIMER15_CH0, TIMER7_BRKIN, TRGSEL_OUT2, EVENTOUT Additional: ADC01_IN6
PA7	32	I/O	-	Default: PA7 Alternate: SPI0_MOSI, TIMER2_CH1,

GD32F502Vx LQFP100				
Pin Name	Pins	Pin Type <sup>(1)</sup>	I/O Level <sup>(2)</sup>	Functions description
				TIMER0_CH0_ON, TIMER15_CH1, TIMER7_CH0_ON, TRGSEL_OUT3, EVENTOUT Additional: ADC01_IN7
PC4	33	I/O	-	Default: PC4 Alternate: TIMER7_CH3, EVENTOUT Additional: ADC01_IN14
PC5	34	I/O	-	Default: PC5 Alternate: EVENTOUT Additional: ADC01_IN15
PB0	35	I/O	-	Default: PB0 Alternate: TIMER0_CH1_ON, TIMER2_CH2, TIMER7_CH1_ON, EVENTOUT Additional: ADC01_IN8
PB1	36	I/O	-	Default: PB1 Alternate: TIMER0_CH2_ON, TIMER2_CH3, TIMER7_CH2_ON, EVENTOUT Additional: ADC01_IN9
PB2/BOOT1	37	I/O	5VT	Default: BOOT1 Alternate: EVENTOUT
PE7	38	I/O	5VT	Default: PE7 Alternate: TIMER0_ETI, EVENTOUT Additional: ADC2_IN4
PE8	39	I/O	5VT	Default: PE8 Alternate: TIMER0_CH0_ON, EVENTOUT Additional: ADC2_IN5
PE9	40	I/O	5VT	Default: PE9 Alternate: TIMER0_CH0, EVENTOUT Additional: ADC2_IN6
PE10	41	I/O	5VT	Default: PE10 Alternate: TIMER0_CH1_ON, EVENTOUT Additional: ADC2_IN7
PE11	42	I/O	5VT	Default: PE11 Alternate: TIMER0_CH1, TRGSEL_IN4, EVENTOUT Additional: ADC2_IN8
PE12	43	I/O	5VT	Default: PE12 Alternate: TIMER0_CH2_ON, EVENTOUT Additional: ADC2_IN9
PE13	44	I/O	5VT	Default: PE13 Alternate: TIMER0_CH2, EVENTOUT
PE14	45	I/O	5VT	Default: PE14 Alternate: TIMER0_CH3, TIMER0_CH2BRKIN, EVENTOUT
PE15	46	I/O	5VT	Default: PE15 Alternate: TIMER0_BRKIN, EVENTOUT Additional: ADC2_IN14

GD32F502Vx LQFP100				
Pin Name	Pins	Pin Type <sup>(1)</sup>	I/O Level <sup>(2)</sup>	Functions description
PB10	47	I/O	5VT	Default: PB10 Alternate: TIMER1_CH2, USART2_TX, I2C1_SCL, TIMER0_CH0BRKIN, EVENTOUT Additional: ADC2_IN15, ADC1_IN16
PB11	48	I/O	5VT	Default: PB11 Alternate: TIMER1_CH3, USART2_RX, I2C1_SDA, TIMER0_CH1BRKIN, TRGSEL_IN1, EVENTOUT Additional: ADC2_IN16, ADC1_IN17
VSS	49	P	-	Default: VSS
VDD	50	P	-	Default: VDD
PB12	51	I/O	5VT	Default: PB12 Alternate: USART2_CK, SPI1_NSS, I2S1_WS, I2C1_SMBA, CAN1_RX, TIMER0_BRKIN, TIMER16_CH0, EVENTOUT
PB13	52	I/O	5VT	Default: PB13 Alternate: USART2_CTS, SPI1_SCK, I2S1_CK, TIMER0_CH0_ON, CAN1_TX, TIMER16_CH1, EVENTOUT
PB14	53	I/O	5VT	Default: PB14 Alternate: USART2_RTS, SPI1_MISO, TIMER0_CH1_ON, TIMER15_CH0, EVENTOUT
PB15	54	I/O	5VT	Default: PB15 Alternate: SPI1_MOSI, I2S1_SD, TIMER0_CH2_ON, TIMER15_CH1, EVENTOUT
PD8	55	I/O	5VT	Default: PD8 Alternate: USART2_TX, TIMER0_CH0BRKIN, EVENTOUT
PD9	56	I/O	5VT	Default: PD9 Alternate: USART2_RX, TIMER0_CH1BRKIN, EVENTOUT
PD10	57	I/O	5VT	Default: PD10 Alternate: USART2_CK, TIMER0_CH2BRKIN, EVENTOUT
PD11	58	I/O	5VT	Default: PD11 Alternate: USART2_CTS, TRGSEL_IN3, EVENTOUT
PD12	59	I/O	5VT	Default: PD12 Alternate: USART2_RTS, TIMER3_CH0, EVENTOUT
PD13	60	I/O	5VT	Default: PD13 Alternate: TIMER3_CH1, EVENTOUT
PD14	61	I/O	5VT	Default: PD14 Alternate: TIMER3_CH2, EVENTOUT
PD15	62	I/O	5VT	Default: PD15 Alternate: TIMER3_CH3, CTC_SYNC, EVENTOUT
PC6	63	I/O	5VT	Default: PC6

GD32F502Vx LQFP100				
Pin Name	Pins	Pin Type <sup>(1)</sup>	I/O Level <sup>(2)</sup>	Functions description
				Alternate: TIMER2_CH0, I2S1_MCK, TIMER7_CH0, EVENTOUT
PC7	64	I/O	5VT	Default: PC7 Alternate: TIMER2_CH1, I2S2_MCK, TIMER7_CH3_ON, TIMER7_CH1, EVENTOUT
PC8	65	I/O	5VT	Default: PC8 Alternate: TIMER2_CH2, TIMER7_CH2, EVENTOUT
PC9	66	I/O	5VT	Default: PC9 Alternate: TIMER2_CH3, TIMER7_CH3, EVENTOUT
PA8	67	I/O	5VT	Default: PA8 Alternate: USART0_CK, TIMER0_CH0, USBFS_SOF, CK_OUT, TIMER7_CH0BRKIN, CTC_SYNC, TRGSEL_OUT4, EVENTOUT
PA9	68	I/O	5VT	Default: PA9 Alternate: USART0_TX, TIMER0_CH1, TIMER7_CH1BRKIN, TRGSEL_OUT5, EVENTOUT
PA10	69	I/O	5VT	Default: PA10 Alternate: USART0_RX, TIMER0_CH2, TIMER0_CH3_ON, TIMER15_BRKIN, TIMER15_CH1, TIMER7_CH2BRKIN, EVENTOUT
PA11	70	I/O	5VT	Default: PA11 Alternate: USART0_CTS, CAN0_RX, TIMER0_CH3, TIMER7_CH0, TIMER15_CH0, TRGSEL_IN0, EVENTOUT Additional: USBFS_DM
PA12	71	I/O	5VT	Default: PA12 Alternate: USART0_RTS, CAN0_TX, TIMER0_ETI, TIMER7_CH1, TIMER15_MCH0, EVENTOUT Additional: USBFS_DP
PA13	72	I/O	5VT	Default: JTMS, SWDIO, PA13 Alternate: EVENTOUT
NC	73	-	-	Default: NC
VSS	74	P	-	Default: VSS
VDD	75	P	-	Default: VDD
PA14	76	I/O	5VT	Default: JTCK, SWCLK, PA14 Alternate: EVENTOUT
PA15	77	I/O	5VT	Default: JTDI, PA15 Alternate: TIMER1_CH0, TIMER1_ETI, SPI0_NSS, SPI2_NSS, I2S2_WS, TIMER15_BRKIN, TIMER16_BRKIN, EVENTOUT
PC10	78	I/O	5VT	Default: PC10 Alternate: USART2_TX, UART3_TX, SPI2_SCK, I2S2_CK, TIMER7_CH0BRKIN, TIMER0_CH0BRKIN, EVENTOUT
PC11	79	I/O	5VT	Default: PC11

GD32F502Vx LQFP100				
Pin Name	Pins	Pin Type <sup>(1)</sup>	I/O Level <sup>(2)</sup>	Functions description
				Alternate: USART2_RX, UART3_RX, SPI2_MISO, TIMER7_CH2BRKIN, TIMER16_CH1, TRGSEL_IN2, EVENTOUT
PC12	80	I/O	5VT	Default: PC12 Alternate: USART2_CK, UART4_TX, SPI2_MOSI, I2S2_SD, TIMER16_CH0, EVENTOUT
PD0	81	I/O	5VT	Default: PD0 Alternate: CAN0_RX, EVENTOUT
PD1	82	I/O	5VT	Default: PD1 Alternate: CAN0_TX, EVENTOUT
PD2	83	I/O	5VT	Default: PD2 Alternate: TIMER2_ETI, UART4_RX, TIMER16_MCH0, EVENTOUT
PD3	84	I/O	5VT	Default: PD3 Alternate: USART1_CTS, EVENTOUT
PD4	85	I/O	5VT	Default: PD4 Alternate: USART1_RTS, EVENTOUT
PD5	86	I/O	5VT	Default: PD5 Alternate: USART1_TX, EVENTOUT
PD6	87	I/O	5VT	Default: PD6 Alternate: USART1_RX, EVENTOUT
PD7	88	I/O	5VT	Default: PD7 Alternate: USART1_CK, EVENTOUT
PB3	89	I/O	5VT	Default: JTDO, PB3 Alternate: TRACESWO, TIMER1_CH1, SPI0_SCK, SPI2_SCK, I2S2_CK, CK_OUT, EVENTOUT
PB4	90	I/O	5VT	Default: NJTRST, PB4 Alternate: TIMER2_CH0, SPI0_MISO, SPI2_MISO, TIMER7_CH2, TRGSEL_OUT6, EVENTOUT
PB5	91	I/O	-	Default: PB5 Alternate: TIMER2_CH1, SPI0_MOSI, I2C0_SMBA, CAN1_RX, TIMER7_CH0BRKIN, SPI2_MOSI, I2S2_SD, TIMER0_CH0BRKIN, EVENTOUT
PB6	92	I/O	5VT	Default: PB6 Alternate: USART0_TX, I2C0_SCL, TIMER3_CH0, CAN1_TX, TIMER7_CH1BRKIN, SPI0_IO2, TIMER0_CH1BRKIN, EVENTOUT
PB7	93	I/O	5VT	Default: PB7 Alternate: USART0_RX, I2C0_SDA, TIMER3_CH1, TIMER7_CH2BRKIN, SPI0_IO3, TRGSEL_OUT7, TIMER0_CH2BRKIN, EVENTOUT
BOOT0	94	I/O	-	Default: BOOT0
PB8	95	I/O	5VT	Default: PB8 Alternate: TIMER3_CH2, I2C0_SCL, CAN0_RX, TIMER15_CH0, EVENTOUT

GD32F502Vx LQFP100				
Pin Name	Pins	Pin Type <sup>(1)</sup>	I/O Level <sup>(2)</sup>	Functions description
PB9	96	I/O	5VT	Default: PB9 Alternate: I2C0_SDA, CAN0_TX, TIMER3_CH3, TIMER16_CH0, EVENTOUT
PE0	97	I/O	5VT	Default: PE0 Alternate: TIMER3_ETI, TRGSEL_IN7, EVENTOUT
PE1	98	I/O	5VT	Default: PE1 Alternate: EVENTOUT
VSS	99	P	-	Default: VSS
VDD	100	P	-	Default: VDD

(1) Type: I = input, O = output, P = power.

(2) I/O Level: 5VT = 5 V tolerant.

## 2.6.2. GD32F502Rx LQFP64 pin definitions

**Table 2-4. GD32F502Rx LQFP64 pin definitions**

GD32F502Rx LQFP64				
Pin Name	Pins	Pin Type <sup>(1)</sup>	I/O Level <sup>(2)</sup>	Functions description
VBAT	1	P	-	Default: VBAT
PC13	2	I/O	-	Default: PC13 Alternate: EVENTOUT Additional: TAMPER-RTC
PC14- OSC32IN	3	I/O	-	Default: PC14, OSC32IN Alternate: EVENTOUT Additional: OSC32IN
PC15- OSC32OUT	4	I/O	-	Default: PC15, OSC32OUT Alternate: EVENTOUT Additional: OSC32OUT
OSCIN-PD0	5	I/O	-	Default: OSCIN, PD0 Alternate: EVENTOUT Additional: OSCIN
OSCOUT- PD1	6	I/O	-	Default: OSCOUT, PD1 Alternate: EVENTOUT Additional: OSCOUT
NRST	7	-	-	Default: NRST
PC0	8	I/O	-	Default: PC0 Alternate: TIMER7_CH0_ON, EVENTOUT Additional: ADC012_IN10
PC1	9	I/O	-	Default: PC1 Alternate: TIMER7_CH1_ON, EVENTOUT Additional: ADC012_IN11
PC2	10	I/O	-	Default: PC2 Alternate: TIMER7_CH2_ON, EVENTOUT Additional: ADC012_IN12
PC3	11	I/O	-	Default: PC3 Alternate: TIMER7_CH3_ON, EVENTOUT Additional: ADC012_IN13
VSSA/VREF N	12	P	-	Default: VSSA
VDDA/VREF P	13	P	-	Default: VDDA
PA0	14	I/O	-	Default: PA0 Alternate: USART1_CTS, TIMER1_CH0, TIMER1_ETI, TIMER16_BRKIN, TIMER4_CH0, TIMER7_ETI, TRGSEL_IN5, EVENTOUT Additional: ADC012_IN0, WKUP
PA1	15	I/O	-	Default: PA1

GD32F502Rx LQFP64				
Pin Name	Pins	Pin Type <sup>(1)</sup>	I/O Level <sup>(2)</sup>	Functions description
				Alternate: USART1_RTS, TIMER1_CH1, TIMER16_MCH0, TIMER4_CH1, TRGSEL_IN6, EVENTOUT Additional: ADC012_IN1
PA2	16	I/O	-	Default: PA2 Alternate: USART1_TX, TIMER1_CH2, TIMER16_CH0, TIMER4_CH2, SPI0_IO2, TRGSEL_OUT0, EVENTOUT Additional: ADC012_IN2
PA3	17	I/O	-	Default: PA3 Alternate: USART1_RX, TIMER1_CH3, TIMER16_CH1, TIMER4_CH3, TIMER0_CH3_ON, SPI0_IO3, TRGSEL_OUT1, EVENTOUT Additional: ADC012_IN3
VSS	18	P	-	Default: VSS
VDD	19	P	-	Default: VDD
PA4	20	I/O	-	Default: PA4 Alternate: SPI0_NSS, USART1_CK, SPI2_NSS, I2S2_WS, TIMER15_BRKIN, TIMER7_CH1BRKIN, EVENTOUT Additional: ADC01_IN4, DAC0_OUT0
PA5	21	I/O	-	Default: PA5 Alternate: SPI0_SCK, TIMER4_ETI, TIMER15_MCH0, TIMER7_CH0BRKIN, EVENTOUT Additional: ADC01_IN5, DAC0_OUT0
PA6	22	I/O	-	Default: PA6 Alternate: SPI0_MISO, TIMER2_CH0, TIMER0_BRKIN, TIMER15_CH0, TIMER7_BRKIN, TRGSEL_OUT2, EVENTOUT Additional: ADC01_IN6
PA7	23	I/O	-	Default: PA7 Alternate: SPI0_MOSI, TIMER2_CH1, TIMER0_CH0_ON, TIMER15_CH1, TIMER7_CH0_ON, TRGSEL_OUT3, EVENTOUT Additional: ADC01_IN7
PC4	24	I/O	-	Default: PC4 Alternate: TIMER7_CH3, EVENTOUT Additional: ADC01_IN14
PC5	25	I/O	-	Default: PC5 Alternate: EVENTOUT Additional: ADC01_IN15
PB0	26	I/O	-	Default: PB0 Alternate: TIMER0_CH1_ON, TIMER2_CH2, TIMER7_CH1_ON, EVENTOUT Additional: ADC01_IN8
PB1	27	I/O	-	Default: PB1

GD32F502Rx LQFP64				
Pin Name	Pins	Pin Type <sup>(1)</sup>	I/O Level <sup>(2)</sup>	Functions description
				Alternate: TIMER0_CH2_ON, TIMER2_CH3, TIMER7_CH2_ON, EVENTOUT Additional: ADC01_IN9
PB2/BOOT1	28	I/O	5VT	Default: BOOT1 Alternate: EVENTOUT
PB10	29	I/O	5VT	Default: PB10 Alternate: TIMER1_CH2, USART2_TX, I2C1_SCL, TIMER0_CH0BRKIN, EVENTOUT Additional: ADC2_IN15, ADC1_IN16
PB11	30	I/O	5VT	Default: PB11 Alternate: TIMER1_CH3, USART2_RX, I2C1_SDA, TIMER0_CH1BRKIN, TRGSEL_IN1, EVENTOUT Additional: ADC2_IN16, ADC1_IN17
VSS	31	P	-	Default: VSS
VDD	32	P	-	Default: VDD
PB12	33	I/O	5VT	Default: PB12 Alternate: USART2_CK, SPI1_NSS, I2S1_WS, I2C1_SMBA, CAN1_RX, TIMER0_BRKIN, TIMER16_CH0, EVENTOUT
PB13	34	I/O	5VT	Default: PB13 Alternate: USART2_CTS, SPI1_SCK, I2S1_CK, TIMER0_CH0_ON, CAN1_TX, TIMER16_CH1, EVENTOUT
PB14	35	I/O	5VT	Default: PB14 Alternate: USART2_RTS, SPI1_MISO, TIMER0_CH1_ON, TIMER15_CH0, EVENTOUT
PB15	36	I/O	5VT	Default: PB15 Alternate: SPI1_MOSI, I2S1_SD, TIMER0_CH2_ON, TIMER15_CH1, EVENTOUT
PC6	37	I/O	5VT	Default: PC6 Alternate: TIMER2_CH0, I2S1_MCK, TIMER7_CH0, EVENTOUT
PC7	38	I/O	5VT	Default: PC7 Alternate: TIMER2_CH1, I2S2_MCK, TIMER7_CH3_ON, TIMER7_CH1, EVENTOUT
PC8	39	I/O	5VT	Default: PC8 Alternate: TIMER2_CH2, TIMER7_CH2, EVENTOUT
PC9	40	I/O	5VT	Default: PC9 Alternate: TIMER2_CH3, TIMER7_CH3, EVENTOUT
PA8	41	I/O	5VT	Default: PA8 Alternate: USART0_CK, TIMER0_CH0, USBFS_SOF, CK_OUT, TIMER7_CH0BRKIN, CTC_SYNC, TRGSEL_OUT4, EVENTOUT
PA9	42	I/O	5VT	Default: PA9 Alternate: USART0_TX, TIMER0_CH1,

GD32F502Rx LQFP64				
Pin Name	Pins	Pin Type <sup>(1)</sup>	I/O Level <sup>(2)</sup>	Functions description
				TIMER7_CH1BRKIN, TRGSEL_OUT5, EVENTOUT
PA10	43	I/O	5VT	Default: PA10 Alternate: USART0_RX, TIMER0_CH2, TIMER0_CH3_ON, TIMER15_BRKIN, TIMER15_CH1, TIMER7_CH2BRKIN, EVENTOUT
PA11	44	I/O	5VT	Default: PA11 Alternate: USART0_CTS, CAN0_RX, TIMER0_CH3, TIMER7_CH0, TIMER15_CH0, TRGSEL_IN0, EVENTOUT Additional: USBFS_DM
PA12	45	I/O	5VT	Default: PA12 Alternate: USART0_RTS, CAN0_TX, TIMER0_ETI, TIMER7_CH1, TIMER15_MCH0, EVENTOUT Additional: USBFS_DP
PA13	46	I/O	5VT	Default: JTMS, SWDIO, PA13 Alternate: EVENTOUT
VSS	47	P	-	Default: VSS
VDD	48	P	-	Default: VDD
PA14	49	I/O	5VT	Default: JTCK, SWCLK, PA14 Alternate: EVENTOUT
PA15	50	I/O	5VT	Default: JTDI, PA15 Alternate: TIMER1_CH0, TIMER1_ETI, SPI0_NSS, SPI2_NSS, I2S2_WS, TIMER15_BRKIN, TIMER16_BRKIN, EVENTOUT
PC10	51	I/O	5VT	Default: PC10 Alternate: USART2_TX, UART3_TX, SPI2_SCK, I2S2_CK, TIMER7_CH0BRKIN, TIMER0_CH0BRKIN, EVENTOUT
PC11	52	I/O	5VT	Default: PC11 Alternate: USART2_RX, UART3_RX, SPI2_MISO, TIMER7_CH2BRKIN, TIMER16_CH1, TRGSEL_IN2, EVENTOUT
PC12	53	I/O	5VT	Default: PC12 Alternate: USART2_CK, UART4_TX, SPI2_MOSI, I2S2_SD, TIMER16_CH0, EVENTOUT
PD2	54	I/O	5VT	Default: PD2 Alternate: TIMER2_ETI, UART4_RX, TIMER16_MCH0, EVENTOUT
PB3	55	I/O	5VT	Default: JTDO, PB3 Alternate: TRACESWO, TIMER1_CH1, SPI0_SCK, SPI2_SCK, I2S2_CK, CK_OUT, EVENTOUT
PB4	56	I/O	5VT	Default: NJTRST, PB4 Alternate: TIMER2_CH0, SPI0_MISO, SPI2_MISO, TIMER7_CH2, TRGSEL_OUT6, EVENTOUT
PB5	57	I/O	-	Default: PB5

GD32F502Rx LQFP64				
Pin Name	Pins	Pin Type <sup>(1)</sup>	I/O Level <sup>(2)</sup>	Functions description
				Alternate: TIMER2_CH1, SPI0_MOSI, I2C0_SMBA, CAN1_RX, TIMER7_CH0BRKIN, SPI2_MOSI, I2S2_SD, TIMER0_CH0BRKIN, EVENTOUT
PB6	58	I/O	5VT	Default: PB6 Alternate: USART0_TX, I2C0_SCL, TIMER3_CH0, CAN1_TX, TIMER7_CH1BRKIN, SPI0_IO2, TIMER0_CH1BRKIN, EVENTOUT
PB7	59	I/O	5VT	Default: PB7 Alternate: USART0_RX, I2C0_SDA, TIMER3_CH1, TIMER7_CH2BRKIN, SPI0_IO3, TRGSEL_OUT7, TIMER0_CH2BRKIN, EVENTOUT
BOOT0	60	I/O	-	Default: BOOT0
PB8	61	I/O	5VT	Default: PB8 Alternate: TIMER3_CH2, I2C0_SCL, CAN0_RX, TIMER15_CH0, EVENTOUT
PB9	62	I/O	5VT	Default: PB9 Alternate: I2C0_SDA, CAN0_TX, TIMER3_CH3, TIMER16_CH0, EVENTOUT
VSS	63	P	-	Default: VSS
VDD	64	P	-	Default: VDD

(1) Type: I = input, O = output, P = power.

(2) I/O Level: 5VT = 5 V tolerant.

### 2.6.3. GD32F502Rx QFN64 pin definitions

**Table 2-5. GD32F502Rx QFN64 pin definitions**

GD32F502Rx QFN64				
Pin Name	Pins	Pin Type <sup>(1)</sup>	I/O Level <sup>(2)</sup>	Functions description
PE5	1	I/O	5VT	Default: PE5 Alternate: TIMER15_CH0, EVENTOUT
PE6	2	I/O	5VT	Default: PE6 Alternate: TIMER15_CH1, EVENTOUT
VBAT	3	P	-	Default: VBAT
PC13	4	I/O	-	Default: PC13 Alternate: EVENTOUT Additional: TAMPER-RTC
PC14- OSC32IN	5	I/O	-	Default: PC14, OSC32IN Alternate: EVENTOUT Additional: OSC32IN
PC15- OSC32OUT	6	I/O	-	Default: PC15, OSC32OUT Alternate: EVENTOUT Additional: OSC32OUT
OSCIN-PD0	7	I/O	-	Default: OSCIN, PD0 Alternate: EVENTOUT Additional: OSCIN
OSCOU- PD1	8	I/O	-	Default: OSCOUT, PD1 Alternate: EVENTOUT Additional: OSCOUT
NRST	9	-	-	Default: NRST
PC0	10	I/O	-	Default: PC0 Alternate: TIMER7_CH0_ON, EVENTOUT Additional: ADC012_IN10
PC1	11	I/O	-	Default: PC1 Alternate: TIMER7_CH1_ON, EVENTOUT Additional: ADC012_IN11
PC2	12	I/O	-	Default: PC2 Alternate: TIMER7_CH2_ON, EVENTOUT Additional: ADC012_IN12
PC3	13	I/O	-	Default: PC3 Alternate: TIMER7_CH3_ON, EVENTOUT Additional: ADC012_IN13
VDDA/VREF P	14	P	-	Default: VDDA
PA0	15	I/O	-	Default: PA0 Alternate: USART1_CTS, TIMER1_CH0, TIMER1_ETI, TIMER16_BRKIN, TIMER4_CH0, TIMER7_ETI, TRGSEL_IN5, EVENTOUT Additional: ADC012_IN0, WKUP
PA1	16	I/O	-	Default: PA1

GD32F502Rx QFN64				
Pin Name	Pins	Pin Type <sup>(1)</sup>	I/O Level <sup>(2)</sup>	Functions description
				Alternate: USART1_RTS, TIMER1_CH1, TIMER16_MCH0, TIMER4_CH1, TRGSEL_IN6, EVENTOUT Additional: ADC012_IN1
PA2	17	I/O	-	Default: PA2 Alternate: USART1_TX, TIMER1_CH2, TIMER16_CH0, TIMER4_CH2, SPI0_IO2, TRGSEL_OUT0, EVENTOUT Additional: ADC012_IN2
PA3	18	I/O	-	Default: PA3 Alternate: USART1_RX, TIMER1_CH3, TIMER16_CH1, TIMER4_CH3, TIMER0_CH3_ON, SPI0_IO3, TRGSEL_OUT1, EVENTOUT Additional: ADC012_IN3
VDD	19	P	-	Default: VDD
PA4	20	I/O	-	Default: PA4 Alternate: SPI0_NSS, USART1_CK, SPI2_NSS, I2S2_WS, TIMER15_BRKIN, TIMER7_CH1BRKIN, EVENTOUT Additional: ADC01_IN4, DAC0_OUT0
PA5	21	I/O	-	Default: PA5 Alternate: SPI0_SCK, TIMER4_ETI, TIMER15_MCH0, TIMER7_CH0BRKIN, EVENTOUT Additional: ADC01_IN5, DAC0_OUT0
PA6	22	I/O	-	Default: PA6 Alternate: SPI0_MISO, TIMER2_CH0, TIMER0_BRKIN, TIMER15_CH0, TIMER7_BRKIN, TRGSEL_OUT2, EVENTOUT Additional: ADC01_IN6
PA7	23	I/O	-	Default: PA7 Alternate: SPI0_MOSI, TIMER2_CH1, TIMER0_CH0_ON, TIMER15_CH1, TIMER7_CH0_ON, TRGSEL_OUT3, EVENTOUT Additional: ADC01_IN7
PC4	24	I/O	-	Default: PC4 Alternate: TIMER7_CH3, EVENTOUT Additional: ADC01_IN14
PC5	25	I/O	-	Default: PC5 Alternate: EVENTOUT Additional: ADC01_IN15
PB0	26	I/O	-	Default: PB0 Alternate: TIMER0_CH1_ON, TIMER2_CH2, TIMER7_CH1_ON, EVENTOUT Additional: ADC01_IN8
PB1	27	I/O	-	Default: PB1

GD32F502Rx QFN64				
Pin Name	Pins	Pin Type <sup>(1)</sup>	I/O Level <sup>(2)</sup>	Functions description
				Alternate: TIMER0_CH2_ON, TIMER2_CH3, TIMER7_CH2_ON, EVENTOUT Additional: ADC01_IN9
PB2/BOOT1	28	I/O	5VT	Default: BOOT1 Alternate: EVENTOUT
PE15	29	I/O	5VT	Default: PE15 Alternate: TIMER0_BRKIN, EVENTOUT Additional: ADC2_IN14
PB10	30	I/O	5VT	Default: PB10 Alternate: TIMER1_CH2, USART2_TX, I2C1_SCL, TIMER0_CH0BRKIN, EVENTOUT Additional: ADC2_IN15, ADC1_IN16
PB11	31	I/O	5VT	Default: PB11 Alternate: TIMER1_CH3, USART2_RX, I2C1_SDA, TIMER0_CH1BRKIN, TRGSEL_IN1, EVENTOUT Additional: ADC2_IN16, ADC1_IN17
VDD	32	P	-	Default: VDD
PB12	33	I/O	5VT	Default: PB12 Alternate: USART2_CK, SPI1_NSS, I2S1_WS, I2C1_SMBA, CAN1_RX, TIMER0_BRKIN, TIMER16_CH0, EVENTOUT
PB13	34	I/O	5VT	Default: PB13 Alternate: USART2_CTS, SPI1_SCK, I2S1_CK, TIMER0_CH0_ON, CAN1_TX, TIMER16_CH1, EVENTOUT
PB14	35	I/O	5VT	Default: PB14 Alternate: USART2_RTS, SPI1_MISO, TIMER0_CH1_ON, TIMER15_CH0, EVENTOUT
PB15	36	I/O	5VT	Default: PB15 Alternate: SPI1_MOSI, I2S1_SD, TIMER0_CH2_ON, TIMER15_CH1, EVENTOUT
PD15	37	I/O	5VT	Default: PD15 Alternate: TIMER3_CH3, CTC_SYNC, EVENTOUT
PC6	38	I/O	5VT	Default: PC6 Alternate: TIMER2_CH0, I2S1_MCK, TIMER7_CH0, EVENTOUT
PC7	39	I/O	5VT	Default: PC7 Alternate: TIMER2_CH1, I2S2_MCK, TIMER7_CH3_ON, TIMER7_CH1, EVENTOUT
PC8	40	I/O	5VT	Default: PC8 Alternate: TIMER2_CH2, TIMER7_CH2, EVENTOUT
PC9	41	I/O	5VT	Default: PC9 Alternate: TIMER2_CH3, TIMER7_CH3, EVENTOUT
PA8	42	I/O	5VT	Default: PA8 Alternate: USART0_CK, TIMER0_CH0, USBFS_SOF,

GD32F502Rx QFN64				
Pin Name	Pins	Pin Type <sup>(1)</sup>	I/O Level <sup>(2)</sup>	Functions description
				CK_OUT, TIMER7_CH0BRKIN, CTC_SYNC, TRGSEL_OUT4, EVENTOUT
PA9	43	I/O	5VT	Default: PA9 Alternate: USART0_TX, TIMER0_CH1, TIMER7_CH1BRKIN, TRGSEL_OUT5, EVENTOUT
PA10	44	I/O	5VT	Default: PA10 Alternate: USART0_RX, TIMER0_CH2, TIMER0_CH3_ON, TIMER15_BRKIN, TIMER15_CH1, TIMER7_CH2BRKIN, EVENTOUT
PA11	45	I/O	5VT	Default: PA11 Alternate: USART0_CTS, CAN0_RX, TIMER0_CH3, TIMER7_CH0, TIMER15_CH0, TRGSEL_IN0, EVENTOUT Additional: USBFS_DM
PA12	46	I/O	5VT	Default: PA12 Alternate: USART0_RTS, CAN0_TX, TIMER0_ETI, TIMER7_CH1, TIMER15_MCH0, EVENTOUT Additional: USBFS_DP
PA13	47	I/O	5VT	Default: JTMS, SWDIO, PA13 Alternate: EVENTOUT
VDD	48	P	-	Default: VDD
PA14	49	I/O	5VT	Default: JTCK, SWCLK, PA14 Alternate: EVENTOUT
PA15	50	I/O	5VT	Default: JTDI, PA15 Alternate: TIMER1_CH0, TIMER1_ETI, SPI0_NSS, SPI2_NSS, I2S2_WS, TIMER15_BRKIN, TIMER16_BRKIN, EVENTOUT
PC10	51	I/O	5VT	Default: PC10 Alternate: USART2_TX, UART3_TX, SPI2_SCK, I2S2_CK, TIMER7_CH0BRKIN, TIMER0_CH0BRKIN, EVENTOUT
PC11	52	I/O	5VT	Default: PC11 Alternate: USART2_RX, UART3_RX, SPI2_MISO, TIMER7_CH2BRKIN, TIMER16_CH1, TRGSEL_IN2, EVENTOUT
PC12	53	I/O	5VT	Default: PC12 Alternate: USART2_CK, UART4_TX, SPI2_MOSI, I2S2_SD, TIMER16_CH0, EVENTOUT
PD2	54	I/O	5VT	Default: PD2 Alternate: TIMER2_ETI, UART4_RX, TIMER16_MCH0, EVENTOUT
PB3	55	I/O	5VT	Default: JTDO, PB3 Alternate: TRACESWO, TIMER1_CH1, SPI0_SCK, SPI2_SCK, I2S2_CK, CK_OUT, EVENTOUT
PB4	56	I/O	5VT	Default: NJTRST, PB4

GD32F502Rx QFN64				
Pin Name	Pins	Pin Type <sup>(1)</sup>	I/O Level <sup>(2)</sup>	Functions description
				Alternate: TIMER2_CH0, SPI0_MISO, SPI2_MISO, TIMER7_CH2, TRGSEL_OUT6, EVENTOUT
PB5	57	I/O	-	Default: PB5 Alternate: TIMER2_CH1, SPI0_MOSI, I2C0_SMBA, CAN1_RX, TIMER7_CH0BRKIN, SPI2_MOSI, I2S2_SD, TIMER0_CH0BRKIN, EVENTOUT
PB6	58	I/O	5VT	Default: PB6 Alternate: USART0_TX, I2C0_SCL, TIMER3_CH0, CAN1_TX, TIMER7_CH1BRKIN, SPI0_IO2, TIMER0_CH1BRKIN, EVENTOUT
PB7	59	I/O	5VT	Default: PB7 Alternate: USART0_RX, I2C0_SDA, TIMER3_CH1, TIMER7_CH2BRKIN, SPI0_IO3, TRGSEL_OUT7, TIMER0_CH2BRKIN, EVENTOUT
BOOT0	60	I/O	-	Default: BOOT0
PB8	61	I/O	5VT	Default: PB8 Alternate: TIMER3_CH2, I2C0_SCL, CAN0_RX, TIMER15_CH0, EVENTOUT
PB9	62	I/O	5VT	Default: PB9 Alternate: I2C0_SDA, CAN0_TX, TIMER3_CH3, TIMER16_CH0, EVENTOUT
PE0	63	I/O	5VT	Default: PE0 Alternate: TIMER3_ETI, TRGSEL_IN7, EVENTOUT
VDD	64	P	-	Default: VDD

(1) Type: I = input, O = output, P = power.

(2) I/O Level: 5VT = 5 V tolerant.

## 2.6.4. GD32F502Rx BGA64 pin definitions

**Table 2-6. GD32F502Rx BGA64 pin definitions**

GD32F502Rx BGA64				
Pin Name	Pins	Pin Type <sup>(1)</sup>	I/O Level <sup>(2)</sup>	Functions description
VBAT	C2	P	-	Default: VBAT
PC13	B1	I/O	-	Default: PC13 Alternate: EVENTOUT Additional: TAMPER-RTC
PC14- OSC32IN	C1	I/O	-	Default: PC14, OSC32IN Alternate: EVENTOUT Additional: OSC32IN
PC15- OSC32OUT	D1	I/O	-	Default: PC15, OSC32OUT Alternate: EVENTOUT Additional: OSC32OUT
OSCIN-PD0	E1	I/O	-	Default: OSCIN, PD0 Alternate: EVENTOUT Additional: OSCIN
OSCOU- PD1	F1	I/O	-	Default: OSCOUT, PD1 Alternate: EVENTOUT Additional: OSCOUT
NRST	D2	-	-	Default: NRST
PC0	E2	I/O	-	Default: PC0 Alternate: TIMER7_CH0_ON, EVENTOUT Additional: ADC012_IN10
PC1	C3	I/O	-	Default: PC1 Alternate: TIMER7_CH1_ON, EVENTOUT Additional: ADC012_IN11
PC2	D3	I/O	-	Default: PC2 Alternate: TIMER7_CH2_ON, EVENTOUT Additional: ADC012_IN12
PC3	G4	I/O	-	Default: PC3 Alternate: TIMER7_CH3_ON, EVENTOUT Additional: ADC012_IN13
VSSA/VREF N	F2	P	-	Default: VSSA
VDDA/VREF P	G1	P	-	Default: VDDA
PA0	H5	I/O	-	Default: PA0 Alternate: USART1_CTS, TIMER1_CH0, TIMER1_ETI, TIMER16_BRKIN, TIMER4_CH0, TIMER7_ETI, TRGSEL_IN5, EVENTOUT Additional: ADC012_IN0, WKUP
PA1	E3	I/O	-	Default: PA1

GD32F502Rx BGA64				
Pin Name	Pins	Pin Type <sup>(1)</sup>	I/O Level <sup>(2)</sup>	Functions description
				Alternate: USART1_RTS, TIMER1_CH1, TIMER16_MCH0, TIMER4_CH1, TRGSEL_IN6, EVENTOUT Additional: ADC012_IN1
PA2	F3	I/O	-	Default: PA2 Alternate: USART1_TX, TIMER1_CH2, TIMER16_CH0, TIMER4_CH2, SPI0_IO2, TRGSEL_OUT0, EVENTOUT Additional: ADC012_IN2
PA3	H2	I/O	-	Default: PA3 Alternate: USART1_RX, TIMER1_CH3, TIMER16_CH1, TIMER4_CH3, TIMER0_CH3_ON, SPI0_IO3, TRGSEL_OUT1, EVENTOUT Additional: ADC012_IN3
VSS	G2	P	-	Default: VSS
VDD	H1	P	-	Default: VDD
PA4	D4	I/O	-	Default: PA4 Alternate: SPI0_NSS, USART1_CK, SPI2_NSS, I2S2_WS, TIMER15_BRKIN, TIMER7_CH1BRKIN, EVENTOUT Additional: ADC01_IN4, DAC0_OUT0
PA5	E4	I/O	-	Default: PA5 Alternate: SPI0_SCK, TIMER4_ETI, TIMER15_MCH0, TIMER7_CH0BRKIN, EVENTOUT Additional: ADC01_IN5, DAC0_OUT0
PA6	G3	I/O	-	Default: PA6 Alternate: SPI0_MISO, TIMER2_CH0, TIMER0_BRKIN, TIMER15_CH0, TIMER7_BRKIN, TRGSEL_OUT2, EVENTOUT Additional: ADC01_IN6
PA7	H3	I/O	-	Default: PA7 Alternate: SPI0_MOSI, TIMER2_CH1, TIMER0_CH0_ON, TIMER15_CH1, TIMER7_CH0_ON, TRGSEL_OUT3, EVENTOUT Additional: ADC01_IN7
PC4	D5	I/O	-	Default: PC4 Alternate: TIMER7_CH3, EVENTOUT Additional: ADC01_IN14
PC5	F4	I/O	-	Default: PC5 Alternate: EVENTOUT Additional: ADC01_IN15
PB0	E5	I/O	-	Default: PB0 Alternate: TIMER0_CH1_ON, TIMER2_CH2, TIMER7_CH1_ON, EVENTOUT Additional: ADC01_IN8
PB1	F5	I/O	-	Default: PB1

GD32F502Rx BGA64				
Pin Name	Pins	Pin Type <sup>(1)</sup>	I/O Level <sup>(2)</sup>	Functions description
				Alternate: TIMER0_CH2_ON, TIMER2_CH3, TIMER7_CH2_ON, EVENTOUT Additional: ADC01_IN9
PB2/BOOT1	H4	I/O	5VT	Default: BOOT1 Alternate: EVENTOUT
PB10	H6	I/O	5VT	Default: PB10 Alternate: TIMER1_CH2, USART2_TX, I2C1_SCL, TIMER0_CH0BRKIN, EVENTOUT Additional: ADC2_IN15, ADC1_IN16
PB11	H7	I/O	5VT	Default: PB11 Alternate: TIMER1_CH3, USART2_RX, I2C1_SDA, TIMER0_CH1BRKIN, TRGSEL_IN1, EVENTOUT Additional: ADC2_IN16, ADC1_IN17
VSS	G7	P	-	Default: VSS
VDD	H8	P	-	Default: VDD
PB12	G8	I/O	5VT	Default: PB12 Alternate: USART2_CK, SPI1_NSS, I2S1_WS, I2C1_SMBA, CAN1_RX, TIMER0_BRKIN, TIMER16_CH0, EVENTOUT
PB13	G6	I/O	5VT	Default: PB13 Alternate: USART2_CTS, SPI1_SCK, I2S1_CK, TIMER0_CH0_ON, CAN1_TX, TIMER16_CH1, EVENTOUT
PB14	F8	I/O	5VT	Default: PB14 Alternate: USART2_RTS, SPI1_MISO, TIMER0_CH1_ON, TIMER15_CH0, EVENTOUT
PB15	F7	I/O	5VT	Default: PB15 Alternate: SPI1_MOSI, I2S1_SD, TIMER0_CH2_ON, TIMER15_CH1, EVENTOUT
PC6	E8	I/O	5VT	Default: PC6 Alternate: TIMER2_CH0, I2S1_MCK, TIMER7_CH0, EVENTOUT
PC7	E7	I/O	5VT	Default: PC7 Alternate: TIMER2_CH1, I2S2_MCK, TIMER7_CH3_ON, TIMER7_CH1, EVENTOUT
PC8	F6	I/O	5VT	Default: PC8 Alternate: TIMER2_CH2, TIMER7_CH2, EVENTOUT
PC9	D8	I/O	5VT	Default: PC9 Alternate: TIMER2_CH3, TIMER7_CH3, EVENTOUT
PA8	E6	I/O	5VT	Default: PA8 Alternate: USART0_CK, TIMER0_CH0, USBFS_SOF, CK_OUT, TIMER7_CH0BRKIN, CTC_SYNC, TRGSEL_OUT4, EVENTOUT
PA9	D7	I/O	5VT	Default: PA9 Alternate: USART0_TX, TIMER0_CH1,

GD32F502Rx BGA64				
Pin Name	Pins	Pin Type <sup>(1)</sup>	I/O Level <sup>(2)</sup>	Functions description
				TIMER7_CH1BRKIN, TRGSEL_OUT5, EVENTOUT
PA10	D6	I/O	5VT	Default: PA10 Alternate: USART0_RX, TIMER0_CH2, TIMER0_CH3_ON, TIMER15_BRKIN, TIMER15_CH1, TIMER7_CH2BRKIN, EVENTOUT
PA11	C8	I/O	5VT	Default: PA11 Alternate: USART0_CTS, CAN0_RX, TIMER0_CH3, TIMER7_CH0, TIMER15_CH0, TRGSEL_IN0, EVENTOUT Additional: USBFS_DM
PA12	B8	I/O	5VT	Default: PA12 Alternate: USART0_RTS, CAN0_TX, TIMER0_ETI, TIMER7_CH1, TIMER15_MCH0, EVENTOUT Additional: USBFS_DP
PA13	C7	I/O	5VT	Default: JTMS, SWDIO, PA13 Alternate: EVENTOUT
VSS	B7	P	-	Default: VSS
VDD	A8	P	-	Default: VDD
PA14	C6	I/O	5VT	Default: JTCK, SWCLK, PA14 Alternate: EVENTOUT
PA15	A7	I/O	5VT	Default: JTDI, PA15 Alternate: TIMER1_CH0, TIMER1_ETI, SPI0_NSS, SPI2_NSS, I2S2_WS, TIMER15_BRKIN, TIMER16_BRKIN, EVENTOUT
PC10	C5	I/O	5VT	Default: PC10 Alternate: USART2_TX, UART3_TX, SPI2_SCK, I2S2_CK, TIMER7_CH0BRKIN, TIMER0_CH0BRKIN, EVENTOUT
PC11	B6	I/O	5VT	Default: PC11 Alternate: USART2_RX, UART3_RX, SPI2_MISO, TIMER7_CH2BRKIN, TIMER16_CH1, TRGSEL_IN2, EVENTOUT
PC12	A6	I/O	5VT	Default: PC12 Alternate: USART2_CK, UART4_TX, SPI2_MOSI, I2S2_SD, TIMER16_CH0, EVENTOUT
PD2	B5	I/O	5VT	Default: PD2 Alternate: TIMER2_ETI, UART4_RX, TIMER16_MCH0, EVENTOUT
PB3	A5	I/O	5VT	Default: JTDO, PB3 Alternate: TRACESWO, TIMER1_CH1, SPI0_SCK, SPI2_SCK, I2S2_CK, CK_OUT, EVENTOUT
PB4	C4	I/O	5VT	Default: NJTRST, PB4 Alternate: TIMER2_CH0, SPI0_MISO, SPI2_MISO, TIMER7_CH2, TRGSEL_OUT6, EVENTOUT
PB5	B4	I/O	-	Default: PB5

GD32F502Rx BGA64				
Pin Name	Pins	Pin Type <sup>(1)</sup>	I/O Level <sup>(2)</sup>	Functions description
				Alternate: TIMER2_CH1, SPI0_MOSI, I2C0_SMBA, CAN1_RX, TIMER7_CH0BRKIN, SPI2_MOSI, I2S2_SD, TIMER0_CH0BRKIN, EVENTOUT
PB6	A4	I/O	5VT	Default: PB6 Alternate: USART0_TX, I2C0_SCL, TIMER3_CH0, CAN1_TX, TIMER7_CH1BRKIN, SPI0_IO2, TIMER0_CH1BRKIN, EVENTOUT
PB7	A3	I/O	5VT	Default: PB7 Alternate: USART0_RX, I2C0_SDA, TIMER3_CH1, TIMER7_CH2BRKIN, SPI0_IO3, TRGSEL_OUT7, TIMER0_CH2BRKIN, EVENTOUT
BOOT0	B3	I/O	-	Default: BOOT0
PB8	G5	I/O	5VT	Default: PB8 Alternate: TIMER3_CH2, I2C0_SCL, CAN0_RX, TIMER15_CH0, EVENTOUT
PB9	A2	I/O	5VT	Default: PB9 Alternate: I2C0_SDA, CAN0_TX, TIMER3_CH3, TIMER16_CH0, EVENTOUT
VSS	B2	P	-	Default: VSS
VDD	A1	P	-	Default: VDD

(1) Type: I = input, O = output, P = power.

(2) I/O Level: 5VT = 5 V tolerant.

### 2.6.5. GD32F502Cx LQFP48 pin definitions

**Table 2-7. GD32F502Cx LQFP48 pin definitions**

GD32F502Cx LQFP48				
Pin Name	Pins	Pin Type <sup>(1)</sup>	I/O Level <sup>(2)</sup>	Functions description
VBAT	1	P	-	Default: VBAT
PC13	2	I/O	-	Default: PC13 Alternate: EVENTOUT Additional: TAMPER-RTC
PC14-OSC32IN	3	I/O	-	Default: PC14, OSC32IN Alternate: EVENTOUT Additional: OSC32IN
PC15-OSC32OUT	4	I/O	-	Default: PC15, OSC32OUT Alternate: EVENTOUT Additional: OSC32OUT
OSCIN-PD0	5	I/O	-	Default: OSCIN, PD0 Alternate: EVENTOUT Additional: OSCIN
OSCOUT-PD1	6	I/O	-	Default: OSCOUT, PD1 Alternate: EVENTOUT Additional: OSCOUT
NRST	7	-	-	Default: NRST
VSSA/VREFN	8	P	-	Default: VSSA
VDDA/VREFP	9	P	-	Default: VDDA
PA0	10	I/O	-	Default: PA0 Alternate: USART1_CTS, TIMER1_CH0, TIMER1_ETI, TIMER16_BRKIN, TIMER4_CH0, TIMER7_ETI, TRGSEL_IN5, EVENTOUT Additional: ADC012_IN0, WKUP
PA1	11	I/O	-	Default: PA1 Alternate: USART1_RTS, TIMER1_CH1, TIMER16_MCH0, TIMER4_CH1, TRGSEL_IN6, EVENTOUT Additional: ADC012_IN1
PA2	12	I/O	-	Default: PA2 Alternate: USART1_TX, TIMER1_CH2, TIMER16_CH0, TIMER4_CH2, SPI0_IO2, TRGSEL_OUT0, EVENTOUT Additional: ADC012_IN2
PA3	13	I/O	-	Default: PA3 Alternate: USART1_RX, TIMER1_CH3, TIMER16_CH1, TIMER4_CH3, TIMER0_CH3_ON, SPI0_IO3, TRGSEL_OUT1, EVENTOUT Additional: ADC012_IN3
PA4	14	I/O	-	Default: PA4

GD32F502Cx LQFP48				
Pin Name	Pins	Pin Type <sup>(1)</sup>	I/O Level <sup>(2)</sup>	Functions description
				Alternate: SPI0_NSS, USART1_CK, SPI2_NSS, I2S2_WS, TIMER15_BRKIN, TIMER7_CH1BRKIN, EVENTOUT Additional: ADC01_IN4, DAC0_OUT0
PA5	15	I/O	-	Default: PA5 Alternate: SPI0_SCK, TIMER4_ETI, TIMER15_MCH0, TIMER7_CH0BRKIN, EVENTOUT Additional: ADC01_IN5, DAC0_OUT0
PA6	16	I/O	-	Default: PA6 Alternate: SPI0_MISO, TIMER2_CH0, TIMER0_BRKIN, TIMER15_CH0, TIMER7_BRKIN, TRGSEL_OUT2, EVENTOUT Additional: ADC01_IN6
PA7	17	I/O	-	Default: PA7 Alternate: SPI0_MOSI, TIMER2_CH1, TIMER0_CH0_ON, TIMER15_CH1, TIMER7_CH0_ON, TRGSEL_OUT3, EVENTOUT Additional: ADC01_IN7
PB0	18	I/O	-	Default: PB0 Alternate: TIMER0_CH1_ON, TIMER2_CH2, TIMER7_CH1_ON, EVENTOUT Additional: ADC01_IN8
PB1	19	I/O	-	Default: PB1 Alternate: TIMER0_CH2_ON, TIMER2_CH3, TIMER7_CH2_ON, EVENTOUT Additional: ADC01_IN9
PB2/BOOT1	20	I/O	5VT	Default: BOOT1 Alternate: EVENTOUT
PB10	21	I/O	5VT	Default: PB10 Alternate: TIMER1_CH2, USART2_TX, I2C1_SCL, TIMER0_CH0BRKIN, EVENTOUT Additional: ADC2_IN15, ADC1_IN16
PB11	22	I/O	5VT	Default: PB11 Alternate: TIMER1_CH3, USART2_RX, I2C1_SDA, TIMER0_CH1BRKIN, TRGSEL_IN1, EVENTOUT Additional: ADC2_IN16, ADC1_IN17
VSS	23	P	-	Default: VSS
VDD	24	P	-	Default: VDD
PB12	25	I/O	5VT	Default: PB12 Alternate: USART2_CK, SPI1_NSS, I2S1_WS, I2C1_SMBA, CAN1_RX, TIMER0_BRKIN, TIMER16_CH0, EVENTOUT
PB13	26	I/O	5VT	Default: PB13 Alternate: USART2_CTS, SPI1_SCK, I2S1_CK, TIMER0_CH0_ON, CAN1_TX, TIMER16_CH1,

GD32F502Cx LQFP48				
Pin Name	Pins	Pin Type <sup>(1)</sup>	I/O Level <sup>(2)</sup>	Functions description
				EVENTOUT
PB14	27	I/O	5VT	Default: PB14 Alternate: USART2_RTS, SPI1_MISO, TIMER0_CH1_ON, TIMER15_CH0, EVENTOUT
PB15	28	I/O	5VT	Default: PB15 Alternate: SPI1_MOSI, I2S1_SD, TIMER0_CH2_ON, TIMER15_CH1, EVENTOUT
PA8	29	I/O	5VT	Default: PA8 Alternate: USART0_CK, TIMER0_CH0, USBFS_SOF, CK_OUT, TIMER7_CH0BRKIN, CTC_SYNC, TRGSEL_OUT4, EVENTOUT
PA9	30	I/O	5VT	Default: PA9 Alternate: USART0_TX, TIMER0_CH1, TIMER7_CH1BRKIN, TRGSEL_OUT5, EVENTOUT
PA10	31	I/O	5VT	Default: PA10 Alternate: USART0_RX, TIMER0_CH2, TIMER0_CH3_ON, TIMER15_BRKIN, TIMER15_CH1, TIMER7_CH2BRKIN, EVENTOUT
PA11	32	I/O	5VT	Default: PA11 Alternate: USART0_CTS, CAN0_RX, TIMER0_CH3, TIMER7_CH0, TIMER15_CH0, TRGSEL_IN0, EVENTOUT Additional: USBFS_DM
PA12	33	I/O	5VT	Default: PA12 Alternate: USART0_RTS, CAN0_TX, TIMER0_ETI, TIMER7_CH1, TIMER15_MCH0, EVENTOUT Additional: USBFS_DP
PA13	34	I/O	5VT	Default: JTMS, SWDIO, PA13 Alternate: EVENTOUT
VSS	35	P	-	Default: VSS
VDD	36	P	-	Default: VDD
PA14	37	I/O	5VT	Default: JTCK, SWCLK, PA14 Alternate: EVENTOUT
PA15	38	I/O	5VT	Default: JTDI, PA15 Alternate: TIMER1_CH0, TIMER1_ETI, SPI0_NSS, SPI2_NSS, I2S2_WS, TIMER15_BRKIN, TIMER16_BRKIN, EVENTOUT
PB3	39	I/O	5VT	Default: JTDO, PB3 Alternate: TRACESWO, TIMER1_CH1, SPI0_SCK, SPI2_SCK, I2S2_CK, CK_OUT, EVENTOUT
PB4	40	I/O	5VT	Default: NJTRST, PB4 Alternate: TIMER2_CH0, SPI0_MISO, SPI2_MISO, TIMER7_CH2, TRGSEL_OUT6, EVENTOUT
PB5	41	I/O	-	Default: PB5 Alternate: TIMER2_CH1, SPI0_MOSI, I2C0_SMBA,

GD32F502Cx LQFP48				
Pin Name	Pins	Pin Type <sup>(1)</sup>	I/O Level <sup>(2)</sup>	Functions description
				CAN1_RX, TIMER7_CH0BRKIN, SPI2_MOSI, I2S2_SD, TIMER0_CH0BRKIN, EVENTOUT
PB6	42	I/O	5VT	Default: PB6 Alternate: USART0_TX, I2C0_SCL, TIMER3_CH0, CAN1_TX, TIMER7_CH1BRKIN, SPI0_IO2, TIMER0_CH1BRKIN, EVENTOUT
PB7	43	I/O	5VT	Default: PB7 Alternate: USART0_RX, I2C0_SDA, TIMER3_CH1, TIMER7_CH2BRKIN, SPI0_IO3, TRGSEL_OUT7, TIMER0_CH2BRKIN, EVENTOUT
BOOT0	44	I/O	-	Default: BOOT0
PB8	45	I/O	5VT	Default: PB8 Alternate: TIMER3_CH2, I2C0_SCL, CAN0_RX, TIMER15_CH0, EVENTOUT
PB9	46	I/O	5VT	Default: PB9 Alternate: I2C0_SDA, CAN0_TX, TIMER3_CH3, TIMER16_CH0, EVENTOUT
VSS	47	P	-	Default: VSS
VDD	48	P	-	Default: VDD

(1) Type: I = input, O = output, P = power.

(2) I/O Level: 5VT = 5 V tolerant.

### 2.6.6. GD32F502Cx QFN48 pin definitions

**Table 2-8. GD32F502Cx QFN48 pin definitions**

GD32F502Cx QFN48				
Pin Name	Pins	Pin Type <sup>(1)</sup>	I/O Level <sup>(2)</sup>	Functions description
VBAT	1	P	-	Default: VBAT
PC13	2	I/O	-	Default: PC13 Alternate: EVENTOUT Additional: TAMPER-RTC
PC14- OSC32IN	3	I/O	-	Default: PC14, OSC32IN Alternate: EVENTOUT Additional: OSC32IN
PC15- OSC32OUT	4	I/O	-	Default: PC15, OSC32OUT Alternate: EVENTOUT Additional: OSC32OUT
OSCIN-PD0	5	I/O	-	Default: OSCIN, PD0 Alternate: EVENTOUT Additional: OSCIN
OSCOU- PD1	6	I/O	-	Default: OSCOUT, PD1 Alternate: EVENTOUT Additional: OSCOUT
NRST	7	-	-	Default: NRST
PC3	8	I/O	-	Default: PC3 Alternate: TIMER7_CH3_ON, EVENTOUT Additional: ADC012_IN13
VDDA/VREF P	9	P	-	Default: VDDA
PA0	10	I/O	-	Default: PA0 Alternate: USART1_CTS, TIMER1_CH0, TIMER1_ETI, TIMER16_BRKIN, TIMER4_CH0, TIMER7_ETI, TRGSEL_IN5, EVENTOUT Additional: ADC012_IN0, WKUP
PA1	11	I/O	-	Default: PA1 Alternate: USART1_RTS, TIMER1_CH1, TIMER16_MCH0, TIMER4_CH1, TRGSEL_IN6, EVENTOUT Additional: ADC012_IN1
PA2	12	I/O	-	Default: PA2 Alternate: USART1_TX, TIMER1_CH2, TIMER16_CH0, TIMER4_CH2, SPI0_IO2, TRGSEL_OUT0, EVENTOUT Additional: ADC012_IN2
PA3	13	I/O	-	Default: PA3 Alternate: USART1_RX, TIMER1_CH3, TIMER16_CH1, TIMER4_CH3, TIMER0_CH3_ON, SPI0_IO3, TRGSEL_OUT1, EVENTOUT Additional: ADC012_IN3

GD32F502Cx QFN48				
Pin Name	Pins	Pin Type <sup>(1)</sup>	I/O Level <sup>(2)</sup>	Functions description
PA4	14	I/O	-	Default: PA4 Alternate: SPI0_NSS, USART1_CK, SPI2_NSS, I2S2_WS, TIMER15_BRKIN, TIMER7_CH1BRKIN, EVENTOUT Additional: ADC01_IN4, DAC0_OUT0
PA5	15	I/O	-	Default: PA5 Alternate: SPI0_SCK, TIMER4_ETI, TIMER15_MCH0, TIMER7_CH0BRKIN, EVENTOUT Additional: ADC01_IN5, DAC0_OUT0
PA6	16	I/O	-	Default: PA6 Alternate: SPI0_MISO, TIMER2_CH0, TIMER0_BRKIN, TIMER15_CH0, TIMER7_BRKIN, TRGSEL_OUT2, EVENTOUT Additional: ADC01_IN6
PA7	17	I/O	-	Default: PA7 Alternate: SPI0_MOSI, TIMER2_CH1, TIMER0_CH0_ON, TIMER15_CH1, TIMER7_CH0_ON, TRGSEL_OUT3, EVENTOUT Additional: ADC01_IN7
PB0	18	I/O	-	Default: PB0 Alternate: TIMER0_CH1_ON, TIMER2_CH2, TIMER7_CH1_ON, EVENTOUT Additional: ADC01_IN8
PB1	19	I/O	-	Default: PB1 Alternate: TIMER0_CH2_ON, TIMER2_CH3, TIMER7_CH2_ON, EVENTOUT Additional: ADC01_IN9
PB2/BOOT1	20	I/O	5VT	Default: BOOT1 Alternate: EVENTOUT
PE15	21	I/O	5VT	Default: PE15 Alternate: TIMER0_BRKIN, EVENTOUT Additional: ADC2_IN14
PB10	22	I/O	5VT	Default: PB10 Alternate: TIMER1_CH2, USART2_TX, I2C1_SCL, TIMER0_CH0BRKIN, EVENTOUT Additional: ADC2_IN15, ADC1_IN16
PB11	23	I/O	5VT	Default: PB11 Alternate: TIMER1_CH3, USART2_RX, I2C1_SDA, TIMER0_CH1BRKIN, TRGSEL_IN1, EVENTOUT Additional: ADC2_IN16, ADC1_IN17
VDD	24	P	-	Default: VDD
PB12	25	I/O	5VT	Default: PB12 Alternate: USART2_CK, SPI1_NSS, I2S1_WS, I2C1_SMBA, CAN1_RX, TIMER0_BRKIN, TIMER16_CH0, EVENTOUT

GD32F502Cx QFN48				
Pin Name	Pins	Pin Type <sup>(1)</sup>	I/O Level <sup>(2)</sup>	Functions description
PB13	26	I/O	5VT	Default: PB13 Alternate: USART2_CTS, SPI1_SCK, I2S1_CK, TIMER0_CH0_ON, CAN1_TX, TIMER16_CH1, EVENTOUT
PB14	27	I/O	5VT	Default: PB14 Alternate: USART2_RTS, SPI1_MISO, TIMER0_CH1_ON, TIMER15_CH0, EVENTOUT
PB15	28	I/O	5VT	Default: PB15 Alternate: SPI1_MOSI, I2S1_SD, TIMER0_CH2_ON, TIMER15_CH1, EVENTOUT
PC9	29	I/O	5VT	Default: PC9 Alternate: TIMER2_CH3, TIMER7_CH3, EVENTOUT
PA8	30	I/O	5VT	Default: PA8 Alternate: USART0_CK, TIMER0_CH0, USBFS_SOF, CK_OUT, TIMER7_CH0BRKIN, CTC_SYNC, TRGSEL_OUT4, EVENTOUT
PA9	31	I/O	5VT	Default: PA9 Alternate: USART0_TX, TIMER0_CH1, TIMER7_CH1BRKIN, TRGSEL_OUT5, EVENTOUT
PA10	32	I/O	5VT	Default: PA10 Alternate: USART0_RX, TIMER0_CH2, TIMER0_CH3_ON, TIMER15_BRKIN, TIMER15_CH1, TIMER7_CH2BRKIN, EVENTOUT
PA11	33	I/O	5VT	Default: PA11 Alternate: USART0_CTS, CAN0_RX, TIMER0_CH3, TIMER7_CH0, TIMER15_CH0, TRGSEL_IN0, EVENTOUT Additional: USBFS_DM
PA12	34	I/O	5VT	Default: PA12 Alternate: USART0_RTS, CAN0_TX, TIMER0_ET1, TIMER7_CH1, TIMER15_MCH0, EVENTOUT Additional: USBFS_DP
PA13	35	I/O	5VT	Default: JTMS, SWDIO, PA13 Alternate: EVENTOUT
VDD	36	P	-	Default: VDD
PA14	37	I/O	5VT	Default: JTCK, SWCLK, PA14 Alternate: EVENTOUT
PA15	38	I/O	5VT	Default: JTDI, PA15 Alternate: TIMER1_CH0, TIMER1_ET1, SPI0_NSS, SPI2_NSS, I2S2_WS, TIMER15_BRKIN, TIMER16_BRKIN, EVENTOUT
PB3	39	I/O	5VT	Default: JTDO, PB3 Alternate: TRACESWO, TIMER1_CH1, SPI0_SCK, SPI2_SCK, I2S2_CK, CK_OUT, EVENTOUT
PB4	40	I/O	5VT	Default: NJTRST, PB4

GD32F502Cx QFN48				
Pin Name	Pins	Pin Type <sup>(1)</sup>	I/O Level <sup>(2)</sup>	Functions description
				Alternate: TIMER2_CH0, SPI0_MISO, SPI2_MISO, TIMER7_CH2, TRGSEL_OUT6, EVENTOUT
PB5	41	I/O	-	Default: PB5 Alternate: TIMER2_CH1, SPI0_MOSI, I2C0_SMBA, CAN1_RX, TIMER7_CH0BRKIN, SPI2_MOSI, I2S2_SD, TIMER0_CH0BRKIN, EVENTOUT
PB6	42	I/O	5VT	Default: PB6 Alternate: USART0_TX, I2C0_SCL, TIMER3_CH0, CAN1_TX, TIMER7_CH1BRKIN, SPI0_IO2, TIMER0_CH1BRKIN, EVENTOUT
PB7	43	I/O	5VT	Default: PB7 Alternate: USART0_RX, I2C0_SDA, TIMER3_CH1, TIMER7_CH2BRKIN, SPI0_IO3, TRGSEL_OUT7, TIMER0_CH2BRKIN, EVENTOUT
BOOT0	44	I/O	-	Default: BOOT0
PB8	45	I/O	5VT	Default: PB8 Alternate: TIMER3_CH2, I2C0_SCL, CAN0_RX, TIMER15_CH0, EVENTOUT
PB9	46	I/O	5VT	Default: PB9 Alternate: I2C0_SDA, CAN0_TX, TIMER3_CH3, TIMER16_CH0, EVENTOUT
PE0	47	I/O	5VT	Default: PE0 Alternate: TIMER3_ETI, TRGSEL_IN7, EVENTOUT
VDD	48	P	-	Default: VDD

(1) Type: I = input, O = output, P = power.

(2) I/O Level: 5VT = 5 V tolerant.

### 2.6.7. GD32F502Kx QFN32 pin definitions

**Table 2-9. GD32F502Kx QFN32 pin definitions**

GD32F502Kx QFN32				
Pin Name	Pins	Pin Type <sup>(1)</sup>	I/O Level <sup>(2)</sup>	Functions description
VDD	1	P	-	Default: VDD
OSCIN-PD0	2	I/O	-	Default: OSCIN, PD0 Alternate: EVENTOUT Additional: OSCIN
OSCOU-PD1	3	I/O	-	Default: OSCOUT, PD1 Alternate: EVENTOUT Additional: OSCOUT
NRST	4	-	-	Default: NRST
VDDA/VREFP	5	P	-	Default: VDDA
PA0	6	I/O	-	Default: PA0 Alternate: USART1_CTS, TIMER1_CH0, TIMER1_ETI, TIMER16_BRKIN, TIMER4_CH0, TIMER7_ETI, TRGSEL_IN5, EVENTOUT Additional: ADC012_IN0, WKUP
PA1	7	I/O	-	Default: PA1 Alternate: USART1_RTS, TIMER1_CH1, TIMER16_MCH0, TIMER4_CH1, TRGSEL_IN6, EVENTOUT Additional: ADC012_IN1
PA2	8	I/O	-	Default: PA2 Alternate: USART1_TX, TIMER1_CH2, TIMER16_CH0, TIMER4_CH2, SPI0_IO2, TRGSEL_OUT0, EVENTOUT Additional: ADC012_IN2
PA3	9	I/O	-	Default: PA3 Alternate: USART1_RX, TIMER1_CH3, TIMER16_CH1, TIMER4_CH3, TIMER0_CH3_ON, SPI0_IO3, TRGSEL_OUT1, EVENTOUT Additional: ADC012_IN3
PA4	10	I/O	-	Default: PA4 Alternate: SPI0_NSS, USART1_CK, SPI2_NSS, I2S2_WS, TIMER15_BRKIN, TIMER7_CH1BRKIN, EVENTOUT Additional: ADC01_IN4, DAC0_OUT0
PA5	11	I/O	-	Default: PA5 Alternate: SPI0_SCK, TIMER4_ETI, TIMER15_MCH0, TIMER7_CH0BRKIN, EVENTOUT Additional: ADC01_IN5, DAC0_OUT0
PA6	12	I/O	-	Default: PA6 Alternate: SPI0_MISO, TIMER2_CH0, TIMER0_BRKIN, TIMER15_CH0, TIMER7_BRKIN, TRGSEL_OUT2, EVENTOUT

GD32F502Kx QFN32				
Pin Name	Pins	Pin Type <sup>(1)</sup>	I/O Level <sup>(2)</sup>	Functions description
				Additional: ADC01_IN6
PA7	13	I/O	-	Default: PA7 Alternate: SPI0_MOSI, TIMER2_CH1, TIMER0_CH0_ON, TIMER15_CH1, TIMER7_CH0_ON, TRGSEL_OUT3, EVENTOUT Additional: ADC01_IN7
PB0	14	I/O	-	Default: PB0 Alternate: TIMER0_CH1_ON, TIMER2_CH2, TIMER7_CH1_ON, EVENTOUT Additional: ADC01_IN8
PB1	15	I/O	-	Default: PB1 Alternate: TIMER0_CH2_ON, TIMER2_CH3, TIMER7_CH2_ON, EVENTOUT Additional: ADC01_IN9
PB2/BOOT1	16	I/O	5VT	Default: BOOT1 Alternate: EVENTOUT
VDD	17	P	-	Default: VDD
PA8	18	I/O	5VT	Default: PA8 Alternate: USART0_CK, TIMER0_CH0, USBFS_SOF, CK_OUT, TIMER7_CH0BRKIN, CTC_SYNC, TRGSEL_OUT4, EVENTOUT
PA9	19	I/O	5VT	Default: PA9 Alternate: USART0_TX, TIMER0_CH1, TIMER7_CH1BRKIN, TRGSEL_OUT5, EVENTOUT
PA10	20	I/O	5VT	Default: PA10 Alternate: USART0_RX, TIMER0_CH2, TIMER0_CH3_ON, TIMER15_BRKIN, TIMER15_CH1, TIMER7_CH2BRKIN, EVENTOUT
PA11	21	I/O	5VT	Default: PA11 Alternate: USART0_CTS, CAN0_RX, TIMER0_CH3, TIMER7_CH0, TIMER15_CH0, TRGSEL_IN0, EVENTOUT Additional: USBFS_DM
PA12	22	I/O	5VT	Default: PA12 Alternate: USART0_RTS, CAN0_TX, TIMER0_ETI, TIMER7_CH1, TIMER15_MCH0, EVENTOUT Additional: USBFS_DP
PA13	23	I/O	5VT	Default: JTMS, SWDIO, PA13 Alternate: EVENTOUT
VDD	24	P	-	Default: VDD
PA14	25	I/O	5VT	Default: JTCK, SWCLK, PA14 Alternate: EVENTOUT
PA15	26	I/O	5VT	Default: JTDI, PA15 Alternate: TIMER1_CH0, TIMER1_ETI, SPI0_NSS, SPI2_NSS, I2S2_WS, TIMER15_BRKIN,

GD32F502Kx QFN32				
Pin Name	Pins	Pin Type <sup>(1)</sup>	I/O Level <sup>(2)</sup>	Functions description
				TIMER16_BRKIN, EVENTOUT
PB3	27	I/O	5VT	Default: JTDO, PB3 Alternate: TRACESWO, TIMER1_CH1, SPI0_SCK, SPI2_SCK, I2S2_CK, CK_OUT, EVENTOUT
PB4	28	I/O	5VT	Default: NJTRST, PB4 Alternate: TIMER2_CH0, SPI0_MISO, SPI2_MISO, TIMER7_CH2, TRGSEL_OUT6, EVENTOUT
PB5	29	I/O	-	Default: PB5 Alternate: TIMER2_CH1, SPI0_MOSI, I2C0_SMBA, CAN1_RX, TIMER7_CH0BRKIN, SPI2_MOSI, I2S2_SD, TIMER0_CH0BRKIN, EVENTOUT
PB6	30	I/O	5VT	Default: PB6 Alternate: USART0_TX, I2C0_SCL, TIMER3_CH0, CAN1_TX, TIMER7_CH1BRKIN, SPI0_IO2, TIMER0_CH1BRKIN, EVENTOUT
PB7	31	I/O	5VT	Default: PB7 Alternate: USART0_RX, I2C0_SDA, TIMER3_CH1, TIMER7_CH2BRKIN, SPI0_IO3, TRGSEL_OUT7, TIMER0_CH2BRKIN, EVENTOUT
BOOT0	32	I/O	-	Default: BOOT0

(1) Type: I = input, O = output, P = power.

(2) I/O Level: 5VT = 5 V tolerant.

## 2.6.8. GD32F502xx pin alternate functions

**Table 2-10. Port A alternate functions summary**

Pin Name	AF0	AF1	AF2	AF3	AF4	AF5	AF6	AF7	AF8
PA0	USART1_CTS	TIMER1_CH0/TIMER1_ETI	TIMER16_BRKIN	TIMER4_CH0	TIMER7_ETI		TRGSEL_IN5		EVENTOUT
PA1	USART1_RTS	TIMER1_CH1	TIMER16_MCH0	TIMER4_CH1			TRGSEL_IN6		EVENTOUT
PA2	USART1_TX	TIMER1_CH2	TIMER16_CH0	TIMER4_CH2		SPI0_IO2	TRGSEL_OUT0		EVENTOUT
PA3	USART1_RX	TIMER1_CH3	TIMER16_CH1	TIMER4_CH3	TIMER0_CH3_ON	SPI0_IO3	TRGSEL_OUT1		EVENTOUT
PA4	SPI0_NSS	USART1_CK	SPI2_NSS/I2S2_WS	TIMER15_BRKIN	TIMER7_CH1BRKIN				EVENTOUT
PA5	SPI0_SCK		TIMER4_ETI	TIMER15_MCH0	TIMER7_CH0BRKIN				EVENTOUT
PA6	SPI0_MISO	TIMER2_CH0	TIMER0_BRKIN	TIMER15_CH0	TIMER7_BRKIN		TRGSEL_OUT2		EVENTOUT
PA7	SPI0_MOSI	TIMER2_CH1	TIMER0_CH0_ON	TIMER15_CH1	TIMER7_CH0_ON		TRGSEL_OUT3		EVENTOUT
PA8	USART0_CK	TIMER0_CH0	USBFS_SOF	CK_OUT	TIMER7_CH0BRKIN	CTC_SYNC	TRGSEL_OUT4		EVENTOUT
PA9	USART0_TX	TIMER0_CH1			TIMER7_CH1BRKIN		TRGSEL_OUT5		EVENTOUT
PA10	USART0_RX	TIMER0_CH2	TIMER0_CH3_ON	TIMER15_BRKIN	TIMER15_CH1	TIMER7_CH2BRKIN			EVENTOUT
PA11	USART0_CTS	CAN0_RX	TIMER0_CH3	TIMER7_CH0	TIMER15_CH0		TRGSEL_IN0		EVENTOUT
PA12	USART0_RTS	CAN0_TX	TIMER0_ETI	TIMER7_CH1	TIMER15_MCH0				EVENTOUT
PA13	JTMS/SWDIO								EVENTOUT
PA14	JTCK/SWCLK								EVENTOUT
PA15	JTDI	TIMER1_CH0/TIMER1_ETI	SPI0_NSS	SPI2_NSS/I2S2_WS	TIMER15_BRKIN	TIMER16_BRKIN			EVENTOUT

**Table 2-11. Port B alternate functions summary**

Pin Name	AF0	AF1	AF2	AF3	AF4	AF5	AF6	AF7	AF8
PB0	TIMER0_CH1_ON	TIMER2_CH2		TIMER7_CH1_ON					EVENTOUT
PB1	TIMER0_CH2_ON	TIMER2_CH3		TIMER7_CH2_ON					EVENTOUT
PB2	BOOT1								EVENTOUT
PB3	JTDO/TRACESWO	TIMER1_CH1	SPI0_SCK	SPI2_SCK/I2S2_CK	CK_OUT				EVENTOUT
PB4	NJTRST	TIMER2_CH0	SPI0_MISO	SPI2_MISO	TIMER7_CH2		TRGSEL_OUT6		EVENTOUT
PB5	TIMER2_CH1	SPI0_MOSI	I2C0_SMBA	CAN1_RX	TIMER7_CH0BRKIN	SPI2_MOSI/I2S2_SD	TIMER0_CH0BRKIN		EVENTOUT
PB6	USART0_TX	I2C0_SCL	TIMER3_CH0	CAN1_TX	TIMER7_CH1BRKIN	SPI0_IO2	TIMER0_CH1BRKIN		EVENTOUT
PB7	USART0_RX	I2C0_SDA	TIMER3_CH1		TIMER7_CH2BRKIN	SPI0_IO3	TRGSEL_OUT7	TIMER0_CH2BRKIN	EVENTOUT
PB8	I2C0_SCL	CAN0_RX	TIMER3_CH2		TIMER15_CH0				EVENTOUT
PB9	I2C0_SDA	CAN0_TX	TIMER3_CH3		TIMER16_CH0				EVENTOUT
PB10	TIMER1_CH2	USART2_TX	I2C1_SCL		TIMER0_CH0BRKIN				EVENTOUT

Pin Name	AF0	AF1	AF2	AF3	AF4	AF5	AF6	AF7	AF8
PB11	TIMER1_CH3	USART2_RX	I2C1_SDA		TIMER0_CH1BRKIN		TRGSEL_IN1		EVENTOUT
PB12	USART2_CK	SPI1_NSS/I2S1_WS	I2C1_SMBA	CAN1_RX	TIMER0_BRKIN		TIMER16_CH0		EVENTOUT
PB13	USART2_CTS	SPI1_SCK/I2S1_CK	TIMER0_CH0_ON	CAN1_TX			TIMER16_CH1		EVENTOUT
PB14	USART2_RTS	SPI1_MISO	TIMER0_CH1_ON		TIMER15_CH0				EVENTOUT
PB15	SPI1_MOSI/I2S1_SD	TIMER0_CH2_ON			TIMER15_CH1				EVENTOUT

**Table 2-12. Port C alternate functions summary**

Pin Name	AF0	AF1	AF2	AF3	AF4	AF5	AF6	AF7	AF8
PC0	TIMER7_CH0_ON								EVENTOUT
PC1	TIMER7_CH1_ON								EVENTOUT
PC2	TIMER7_CH2_ON								EVENTOUT
PC3	TIMER7_CH3_ON								EVENTOUT
PC4	TIMER7_CH3								EVENTOUT
PC5									EVENTOUT
PC6	TIMER2_CH0	I2S1_MCK		TIMER7_CH0					EVENTOUT
PC7	TIMER2_CH1	I2S2_MCK	TIMER7_CH3_ON	TIMER7_CH1					EVENTOUT
PC8	TIMER2_CH2		TIMER7_CH2						EVENTOUT
PC9	TIMER2_CH3		TIMER7_CH3						EVENTOUT
PC10	USART2_TX	UART3_TX	SPI2_SCK/I2S2_CK	TIMER7_CH0BRKIN	TIMER0_CH0BRKIN				EVENTOUT
PC11	USART2_RX	UART3_RX	SPI2_MISO	TIMER7_CH2BRKIN	TIMER16_CH1		TRGSEL_IN2		EVENTOUT
PC12	USART2_CK	UART4_TX	SPI2_MOSI/I2S2_SD		TIMER16_CH0				EVENTOUT
PC13									EVENTOUT
PC14									EVENTOUT
PC15									EVENTOUT

**Table 2-13. Port D alternate functions summary**

Pin Name	AF0	AF1	AF2	AF3	AF4	AF5	AF6	AF7	AF8
PD0	CAN0_RX								EVENTOUT
PD1	CAN0_TX								EVENTOUT
PD2	TIMER2_ETI	UART4_RX			TIMER16_MCH0				EVENTOUT
PD3	USART1_CTS								EVENTOUT
PD4	USART1_RTS								EVENTOUT
PD5	USART1_TX								EVENTOUT
PD6	USART1_RX								EVENTOUT
PD7	USART1_CK								EVENTOUT

Pin Name	AF0	AF1	AF2	AF3	AF4	AF5	AF6	AF7	AF8
PD8	USART2_TX				TIMER0_CH0BRKIN				EVENTOUT
PD9	USART2_RX				TIMER0_CH1BRKIN				EVENTOUT
PD10	USART2_CK				TIMER0_CH2BRKIN				EVENTOUT
PD11	USART2_CTS						TRGSEL_IN3		EVENTOUT
PD12	USART2_RTS	TIMER3_CH0							EVENTOUT
PD13	TIMER3_CH1								EVENTOUT
PD14	TIMER3_CH2								EVENTOUT
PD15	TIMER3_CH3		CTC_SYNC						EVENTOUT

**Table 2-14. Port E alternate functions summary**

Pin Name	AF0	AF1	AF2	AF3	AF4	AF5	AF6	AF7	AF8
PE0	TIMER3_ETI						TRGSEL_IN7		EVENTOUT
PE1									EVENTOUT
PE2									EVENTOUT
PE3				TIMER15_BRKIN					EVENTOUT
PE4				TIMER15_MCH0					EVENTOUT
PE5				TIMER15_CH0					EVENTOUT
PE6				TIMER15_CH1					EVENTOUT
PE7	TIMER0_ETI								EVENTOUT
PE8	TIMER0_CH0_ON								EVENTOUT
PE9	TIMER0_CH0								EVENTOUT
PE10	TIMER0_CH1_ON								EVENTOUT
PE11	TIMER0_CH1						TRGSEL_IN4		EVENTOUT
PE12	TIMER0_CH2_ON								EVENTOUT
PE13	TIMER0_CH2								EVENTOUT
PE14	TIMER0_CH3				TIMER0_CH2BRKIN				EVENTOUT
PE15	TIMER0_BRKIN								EVENTOUT

### 3. Functional description

#### 3.1. Arm® Cortex®-M33 core

The Cortex®-M33 processor is a 32-bit processor that possesses low interrupt latency and low-cost debug. The characteristics of integrated and advanced make the Cortex®-M33 processor suitable for market products that require microcontrollers with high performance and low power consumption. The Cortex®-M33 processor is based on the Armv8 architecture and supports a powerful and scalable instruction set including general data processing I/O control tasks, advanced data processing bit field manipulations and DSP. Some system peripherals listed below are also provided by Cortex®-M33:

- Internal Bus Matrix connected with Code bus, System bus, and Private Peripheral Bus (PPB) and debug accesses.
- Nested Vectored Interrupt Controller (NVIC).
- Breakpoint Unit (BPU).
- Data Watchpoint and Trace (DWT).
- Instrumentation Trace Macrocell (ITM).
- Serial Wire JTAG Debug Port (SWJ-DP).
- Trace Port Interface Unit (TPIU).
- Memory Protection Unit (MPU).
- Floating Point Unit (FPU).
- DSP Extension (DSP).
- Software Built-In Self Test (SBIST) controller

#### 3.2. On-chip memory

- Up to 1024KB of main flash memory for instruction and data.
- No waiting time within maximum first 256K bytes when CPU executes instructions. A long delay when CPU fetches the instructions out of the range.
- 16B option bytes block for user application requirements.
- 64Byte OTP0 (One-time program) block used for user data storage.
- 128K byte OTP1 used for BOOT entry or user data storage.
- 256Byte OTP2 with write lock and read lock, used for user data storage.
- 48Byte OTP3 used for critical security configuration.
- Up to 128KB of SRAM.
- Supports 7-bit ECC function when reading and writing first 32KB SRAM.

The GD32F502xx has up to 1024KB of main flash memory for instruction and data. The flash memory consists of 1024KB main flash organized into 384 pages. The flash page size is 2KB for bank0 and 4KB for bank1. Each page of main flash memory can be erased individually.

[Table 2-2. GD32F502xx memory map](#) shows the memory map of the GD32F502xx series

of devices, including Flash, SRAM, peripheral, and other pre-defined regions.

### 3.3. Clock, reset and supply management

- External 4 to 40 MHz crystal oscillator.
- Internal 8 MHz RC oscillator.
- Internal 48 MHz RC oscillator.
- Internal 40 KHz RC calibrated oscillator and external 32.768 KHz crystal oscillator.
- Integrated system clock PLL.
- 2.6V to 3.6V application supply and I/Os.
- Supply Supervisor: POR (Power On Reset), PDR (Power Down Reset), low voltage detector (LVD), VAVD ( $V_{DDA}$  voltage detector), VUVD ( $V_{CORE}$  Under Voltage Detector), VOVD ( $V_{CORE}$  Over Voltage Detector), VBAT for Backup domain.

The Clock Control Unit (CCTL) provides a range of oscillator and clock functions. These include internal RC oscillator and external crystal oscillator, high speed and low speed two types. The frequency of AHB, APB2 and the APB1 domains can be configured by each prescaler. The maximum frequency of the AHB, APB2 and APB1 domains is 200 / 200 / 100MHz, the maximum frequency of the system clock can be up to 200 MHz. See [Figure 2-9. GD32F502xx clock tree](#) for details on the clock tree.

The Reset Control Unit (RCU) controls three kinds of reset: system reset resets the processor core and peripheral IP components except for the SW-DP controller and the Backup domain. Power-on reset (POR) and power-down reset (PDR) are always active, and ensures proper operation starting from 2.40V and down to 2.35V. The device remains in reset mode when  $V_{DD}$  is below a specified threshold. The embedded low voltage detector (LVD) monitors the power supply, compares it to the voltage threshold and generates an interrupt as a warning message for leading the MCU into security.

Power supply schemes:

- $V_{DD}$  range: 2.6V to 3.6V, external power supply for I/Os and the internal regulator. Provided externally through  $V_{DD}$  pins.
- $V_{SSA}$ ,  $V_{DDA}$  range: 2.6V to 3.6V, external analog power supplies for ADC, reset blocks, RCs and PLL.  $V_{DDA}$  and  $V_{SSA}$  must be connected to  $V_{DD}$  and  $V_{SS}$ , respectively.
- $V_{BAT}$  range: 2.6V to 3.6V, power supply for RTC unit, LXTAL oscillator, BPOR and BREG, and three BKP PADS, including PC13 to PC15.

### 3.4. Boot modes

GD32F502xx supports three BOOT modes, including:

- Boot from main Flash memory (default).
- Boot from system memory.
- Boot from on-chip SRAM.

- Boot from OTP1.

The GD32F50x devices provide four kinds of boot sources. The boot mode is influenced by Security Protection, NBTSSB and BTFOSEL bits in OTP3, and Boot pins. The details are shown in the following table [Table 2-15. Boot modes](#).

The value on the BOOT0 and BOOT1 pins is latched on the 4th rising edge of CK\_SYS after a reset. It is up to the user to set the BOOT0 and BOOT1 pins after a power-on reset or a system reset to select the required boot source. Once the two pins have been sampled, they are free and can be used for other purposes.

**Table 2-15. Boot modes**

Security protection	OTP3		Boot pin		BOOT_MODE[2:0]	Boot Select
	NBTSSB	BTFOSEL	BOOT0	BOOT1		
No protection/ Protection level low	0	x	1	1	011	SRAM
No protection/ Protection level low	0	x	1	0	001	BootLoader
No protection/ Protection level low	0	0	0	x	000	Main Flash
No protection/ Protection level low	0	1	0	x	101	OTP1
x	1	0	x	x	000	Main Flash
x	1	1	x	x	101	OTP1
Protection level high	x	0	x	x	000	Main Flash
Protection level high	x	1	x	x	101	OTP1

The boot loader is located in non-user system memory. It is used to reprogram the Flash memory by using USART0 (PA9 and PA10), USART1 (PD5 and PD6 for GD32F502Vx or PA2 and PA3 for GD32F502Rx, GD32F502Cx and GD32F502Kx), USBFS (PA11 PA12) in device mode. It also can be used to transfer and update the Flash memory code, the data and the vector table sections.

**Note:** After the MCU starts from the system memory, the USART interface and the USB interface are in the detection state. Therefore, the unused USART RX pins (PA10, PD6, PA3) need to be maintained at a stable logic level. Unused USB DP pin (PA12) is prohibited from being pulled down and recommended to pull up. This design is made to prevent false triggering during the connection process.

### 3.5. Power saving modes

The MCU supports three kinds of power saving modes to achieve even lower power consumption. They are sleep mode, deep-sleep mode and standby mode. These operating modes reduce the power consumption and allow the application to achieve the best balance between the CPU operating time, speed and power consumption.

#### ■ Sleep mode

In sleep mode, only the clock of CPU core is off. All peripherals continue to operate and any interrupt / event can wake up the system.

#### ■ Deep-sleep mode

In deep-sleep mode, all clocks in the  $V_{CORE}$  domain are off, and all of the high speed crystal oscillator (IRC8M, IRC48M, HXTAL) and PLL are disabled. Only the contents of SRAM and registers are retained. Any interrupt or wakeup event from EXTI lines can wake up the system from the deep-sleep mode including the 16 external lines, the RTC alarm, the LVD output and USBFS wakeup. When exiting the deep-sleep mode, the IRC8M is selected as the system clock.

#### ■ Standby mode

In standby mode, the whole  $V_{CORE}$  domain is power off, the LDO is shut down, and all of IRC8M, IRC48M, HXTAL and PLL are disabled. The contents of SRAM and registers (except backup registers) are lost. There are four wakeup sources for the standby mode, including the external reset from NRST pin, the RTC alarm, the FWDGT reset, and the rising edge on WKUP pin.

### 3.6. Trigger selection controller (TRIGSEL)

- Support up to 74 trigger input signals.
- Each peripheral has its corresponding register to select trigger input signal.
- TRIGSEL register can be configured up to 3 outputs to peripheral.
- Trigger input source could be external input signal or output of peripheral.
- Trigger selection output could be for external output or peripheral input.

The trigger selection controller (TRIGSEL) allows software to select the trigger input signal for various peripherals. TRIGSEL provides a flexible mechanism for a peripheral to select different trigger inputs. With TRIGSEL, there are up to 3 trigger selection outputs could be selected for each peripheral. And every output could be selected from different trigger input signal.

### 3.7. General-purpose and alternate-function I/Os (GPIO and AFIO)

- Up to 80 general purpose I/O pins (GPIO), all mappable on 16 external interrupt lines.

- Each pin weak pull-up / pull-down function.
- Output push-pull / open drain enable control.
- Analog input / output configuration.
- Alternate function input / output configuration.

GD32F502xx is up to 80 general purpose I/O pins (GPIO), named PA0~PA15, PB0~PB15, PC0~PC15, PD0~PD15, PE0~PE15 for the device to implement logic input/output functions. Each GPIO port has related control and configuration registers to satisfy the requirements of specific applications. The external interrupts on the GPIO pins of the device have related control and configuration registers in the Interrupt / Event Controller Unit (EXTI).

Each of the GPIO pins can be configured by software as output (push-pull or open-drain), input, peripheral alternate function or analog mode. Each GPIO pin can be configured as pull-up, pull-down or floating. All GPIOs are high-current capable except for analog mode.

### 3.8. Direct memory access controller (DMA)

- 12 channels (7 for DMA0 and 5 for DMA1) and each channel are configurable.
- Support independent 8, 16, 32-bit memory and peripheral transfer.
- Support independent fixed and increasing address generation algorithm of memory and peripheral.
- Peripherals supported: Timers, ADC, DAC, SPI, I2S, I2C, USART, UART.

The direct memory access (DMA) controller provides a hardware method of transferring data between peripherals and/or memory without intervention from the CPU, thereby freeing up bandwidth for other system functions. Three types of access method are supported: peripheral to memory, memory to peripheral, memory to memory.

There are 12 channels in the DMA controller (7 for DMA0 and 7 for DMA1). Each channel is dedicated to manage memory access requests from one or more peripherals. An arbiter is implemented inside to handle the priority among DMA requests.

### 3.9. DMA request multiplexer (DMAMUX)

- 12 channels for DMAMUX request multiplexer.
- 4 channels for DMAMUX request generator.
- Support 20 trigger inputs and 20 synchronization inputs.

DMAMUX is a transmission scheduler for DMA requests. The DMAMUX request multiplexer is used for routing a DMA request line between the peripherals / generated DMA request (from the DMAMUX request generator) and the DMA controller. Each DMAMUX request multiplexer channel selects a unique DMA request line, unconditionally or synchronously with events from its DMAMUX synchronization inputs. The DMA request is pending until it is served by the DMA controller which generates a DMA acknowledge signal (the DMA request signal is de-asserted).

### 3.10. CRC calculation unit (CRC)

- Supports 8 / 16 / 32 bit data input.
- For 8 / 16 / 32 bit input data length, the calculation cycles are 1 / 2 / 4 AHB clock cycles.
- User configurable polynomial value and size.
- Free 8-bit register is unrelated to calculation and can be used for any other goals by any other peripheral devices.

A cyclic redundancy check (CRC) is an error-detecting code commonly used in digital networks and storage devices to detect accidental changes to raw data. The CRC calculation unit can be used to calculate 7 / 8 / 16 / 32 bit CRC code within user configurable polynomial.

### 3.11. Analog to digital converter (ADC)

- 12-bit, 10-bit, 8-bit or 6-bit configurable resolution for ADC.
- Programmable sampling time.
- DMA support.
- Up to 3 analog watchdogs.
- Oversampling ratio arbitrarily adjustable from 2x to 256x.
- Temperature sensor.
- Input voltage range: VREFN to VREFP.
- Start-of-conversion can be initiated by software or TRIGSEL.

A 12-bit successive approximation analog-to-digital converter module (ADC) is integrated on the MCU chip. ADC0 has 16 external channels, 2 internal channels (temperature sensor, V<sub>REFINT</sub> inputs channel), ADC1 has 18 external channels, ADC2 has 17 external channels. Analog watchdog allows the application to detect if the input voltages exceed the user-set high and low thresholds. All ADC sampling channels support a variety of operation modes. After sampling and conversion, the conversion results can be stored in the corresponding data registers according to the least significant bit (LSB) alignment or the most significant bit (MSB) alignment. An on-chip hardware oversample scheme improves performances and reduces the computational burden of MCU.

To ensure a high accuracy on ADC, the ADC independent external reference voltage should be connected to VREFP/VREFN pins. According to the different packages, VREFP pin can be connected to VDDA pin, or external reference voltage, VREFN pin must be connected to VSSA pin. For packages without VREFP and VREFN pins, V<sub>REFP</sub> is internally connected to V<sub>DDA</sub>, and V<sub>REFN</sub> is internally connected to V<sub>SSA</sub>.

### 3.12. Digital to analog converter (DAC)

- 8-bit or 12-bit resolution.
- Left or right data alignment.
- DMA capability for each channel.

- Conversion update synchronously.
- Conversion triggered by external triggers.
- Configurable internal buffer.
- Extern voltage reference, VREFP.
- Noise wave generation (LFSR noise mode and triangle noise mode).

The Digital-to-analog converter converts 12-bit digital data to a voltage on the external pins. The digital data can be configured to 8-bit or 12-bit mode, left-aligned or right-aligned mode. DMA can be used to update the digital data on external triggers. The output voltage can be optionally buffered for higher drive capability.

### 3.13. Real time clock (RTC)

- 32-bit up-counter with a programmable 20-bit prescaler
- Alarm function

The real time clock is an independent timer which provides a set of continuously running counters in backup registers to provide a real calendar function, and provides an alarm interrupt. The RTC features a 32-bit programmable counter for long-term measurement using the compare register to generate an alarm. A 20-bit prescaler is used for the time base clock and is by default configured to generate a time base of 1 second from a clock of HXTAL clock divided by 128, or LXTAL oscillator clock, or IRC40K oscillator clock, or AHB clock divided by 10.

### 3.14. Timers and PWM generation

- Two 16-bit Advanced timer (TIMER0, TIMER7), three 16-bit General-L0 timers (TIMER2, TIMER3, TIMER4), one 32-bit General-L0 timer (TIMER1), two 16-bit General-L3 timer (TIMER15, TIMER16), two 16-bit Basic timer (TIMER5 & TIMER6).
- Up to 4 independent channels of PWM, output compare or input capture for each general timer and external trigger input.
- 16-bit, motor control PWM advanced timer with programmable dead-time generation for output match.
- Decoder interface controller with two inputs using quadrature decoder and decoder modes.
- 24-bit SysTick timer down counter.
- 2 watchdog timers (free watchdog timer and window watchdog timer).

The advanced timer (TIMER0, TIMER7) can be used as a three-phase PWM multiplexed on 6 channels. It has complementary PWM outputs with programmable dead-time generation. It can also be used as a complete general timer. The 4 independent channels can be used for input capture, output compare, PWM generation (edge-aligned or center-aligned counting modes) and single pulse mode output. It can be synchronized with external signals or interconnect with other general timers together which have the same architecture and features.

The general level 0 timer, can be used for a variety of purposes including general timer, input signal pulse width measurement or output waveform generation such as a single pulse generation or PWM output, up to 4 independent channels for input capture/output compare. TIMER1 is based on a 32-bit auto-reload up/downcounter and a 16-bit prescaler. TIMER2/3/4 is based on a 16-bit auto-reload up/downcounter and a 16-bit prescaler. The general level 0 timer also supports an encoder interface with two inputs using quadrature decoder mode and decoder mode.

The general level3 timer module (TIMER15/TIMER16) is a three-channel timer that supports both input capture and output compare. They can generate PWM signals to control motor or be used for power management applications. The general level3 timer has a 16-bit counter that can be used as an unsigned counter.

The basic timer module (TIMER5/6) has a 16-bit counter that can be used as an unsigned counter. The basic timer TRGO is connected to DAC by TRIGSEL module.

The GD32F502xx has two watchdog peripherals, free watchdog timer and window watchdog timer. They offer a combination of high safety level, flexibility of use and timing accuracy.

The free watchdog timer includes a 12-bit down-counting counter and an 8-bit prescaler. It is clocked from an independent 40 KHz internal RC and as it operates independently of the main clock, it can operate in deep-sleep and standby modes. It can be used either as a watchdog to reset the device when a problem occurs, or as a free-running timer for application timeout management.

The window watchdog timer is based on a 7-bit down counter that can be set as free-running. It can be used as a watchdog to reset the device when a problem occurs. It is clocked from the main clock. It has an early wakeup interrupt capability and the counter can be frozen in debug mode.

The SysTick timer is dedicated for OS, but could also be used as a standard down counter. It features:

- A 24-bit down counter.
- Auto reload capability.
- Maskable system interrupt generation when the counter reaches 0.
- Programmable clock source.

### **3.15. Universal synchronous/asynchronous receiver transmitter (USART/UART)**

- Maximum speed up to 25 MBits/s for USART0 when the clock frequency is 200 MHz and oversampling is by 8.
- Maximum speed up to 12.5 MBits/s for USART1, USART2, UART3 and UART4 when the clock frequency is 100 MHz and oversampling is by 8.
- Supports both asynchronous and clocked synchronous serial communication modes.

- IrDA support.
- LIN break generation and detection.
- ISO 7816-3 compliant smartcard interface.

The USART (USART0, USART1, USART2) and UART (UART3, UART4) are used to transfer data between parallel and serial interfaces, provides a flexible full duplex data exchange using synchronous or asynchronous transfer. It is also commonly used for RS-232 standard communication. The USART/UART includes a programmable baud rate generator which is capable of dividing the system clock to produce a dedicated clock for the USART/UART transmitter and receiver.

### 3.16. Inter-integrated circuit (I2C)

- Up to four I2C bus interfaces can support both master and slave mode with a frequency up to 1 MHz (Fast mode plus).
- Provide arbitration function, optional PEC (packet error checking) generation and checking.
- Supports 7-bit and 10-bit addressing mode and general call addressing mode.
- SMBus 3.0 and PMBus 1.3 compatible.

The I2C (inter-integrated circuit) module provides an I2C interface which is an industry standard two-line serial interface for MCU to communicate with external I2C interface. I2C bus uses two serial lines: a serial data line, SDA, and a serial clock line, SCL. The I2C interface implements standard I2C protocol with standard mode (up to 100KHz), fast mode (up to 400KHz) and fast mode plus (up to 1MHz) as well as CRC calculation and checking, SMBus (system management bus), and PMBus (power management bus).

### 3.17. Controller area network (CAN)

- Supports CAN protocols version 2.0A, B.
- Supports transmitter delay compensation.
- Supports the time-triggered communication.
- Interrupt enable and clear.

CAN bus (Controller Area Network) is a bus standard designed to allow microcontrollers and devices to communicate with each other without a host computer.

As CAN network interface, basic extended CAN supports the CAN protocols version 2.0A, 2.0B. The CAN interface automatically handles the transmission and the reception of CAN frames. The CAN provides 28 scalable/configurable identifier filter banks. The filters are used for selecting the input message as software requirement and otherwise discarding the message. Three transmit mailboxes are provided to the software for transfer messages. The transmission scheduler decides which mailbox will be transmitted firstly. Three complete messages can be stored in every FIFO. The FIFOs are managed completely by hardware. Two receiving FIFOs are used by hardware to store the incoming messages. In addition, the

CAN controller provides all hardware functions, which supports the time-triggered communication option, in safety-critical applications.

### 3.18. Serial peripheral interface (SPI)

- Master or slave operation with full-duplex or simplex mode.
- Separate transmit and receive buffer, 16 bits wide.
- Data frame size can be 8 or 16 bits.
- Hardware CRC calculation, transmission and checking.
- SPI TI mode supported.
- SPI NSS pulse mode supported.
- Quad-SPI configuration available in master mode (only in SPI0).

The SPI interface uses 4 pins, among which are the serial data input and output lines (MISO & MOSI), the clock line (SCK) and the slave select line (NSS). All SPIs can be served by the DMA controller. The serial peripheral interface (SPI) provides a SPI protocol of data transmission and reception function in master or slave mode. Both full-duplex and simplex communication modes are supported, with hardware CRC calculation and checking. Quad-SPI master mode is also supported in SPI0.

### 3.19. Inter-IC sound (I2S)

- Master or slave operation with transmission or reception mode
- Four I2S standards supported: Philips, MSB justified, LSB justified and PCM standard
- Data length can be 16 bits, 24 bits or 32 bits
- Channel length can be 16 bits or 32 bits
- Transmission and reception using a 16 bits wide buffer
- Audio sample frequency can be 8 kHz to 192 kHz using I2S clock divider
- Programmable idle state clock polarity
- Master clock (MCK) can be output
- Transmission and reception using DMA

The inter-IC sound (I2S) supports four audio standards: I2S Philips standard, MSB justified standard, LSB justified standard, and PCM standard. I2S works at either master or slave mode for transmission and reception. The audio sampling frequencies from 8 KHz to 192 KHz is supported.

### 3.20. Universal serial bus full-speed interface (USBFS)

- Supports USB 2.0 host mode at Full-Speed(12Mb/s) or Low-Speed(1.5Mb/s)
- Supports USB 2.0 device mode at Full-Speed(12Mb/s)

USB Full-Speed (USBFS) controller provides a USB-connection solution for portable devices. USBFS supports host and device modes. USBFS contains a full-speed internal USB PHY

and external PHY chip is not contained. USBFS supports all the four types of transfer (control, bulk, Interrupt and isochronous) which defined in USB 2.0 protocol.

### 3.21. Debug mode

- Serial wire JTAG debug port (SWJ-DP).

The GD32F502xx series provide a large variety of debug, trace and test features. They are implemented with a standard configuration of the Arm® CoreSight™ module together with a daisy chained standard TAP controller. Debug and trace functions are integrated into the Arm® Cortex®-M33. The debug system supports serial wire debug (SWD) and trace functions in addition to standard JTAG debug.

### 3.22. Package and operation temperature

- LQFP100 (GD32F502Vx), LQFP64 (GD32F502Rx), QFN64 (GD32F502Rx), BGA64 (GD32F502Rx), LQFP48 (GD32F502Cx), QFN48 (GD32F502Cx) and QFN32 (GD32F502Kx).
- Operation temperature range: -40°C to +85°C (industrial level).

## 4. Electrical characteristics

### 4.1. Parameter introduction

- Parameter conditions: Unless otherwise specified, all values given for  $V_{DD} = V_{DDA} = 3.3$  V,  $V_{CORE} = 1.2$  V,  $T_A = 25^\circ\text{C}$ , and all voltages are referenced to  $V_{SS}$ .
- Value guaranteed by design, not 100% tested in production indicates that the value is derived from design or simulation and/or process characteristics.
- Value guaranteed by characterization, not 100% tested in production indicates that the value is derived from comprehensive evaluation after random test.
- Value guaranteed by sample, not 100% tested in production indicates that the value is derived from testing parameters with a small sample size.
- Guaranteed by characterization, the minimum and maximum values refer to random tests and represent the mean value plus or minus three times the standard deviation (mean  $\pm 3\sigma$ ).
- If the value is not specially indicated, it means the value guaranteed by 100% tested in production.

See the following table for some abbreviation terms and their descriptions in this chapter.

**Table 4-1. Abbreviations**

Acronym	Description
ADC	Analog-to-Digital Converter
AHB	Advanced High-performance Bus
APB	Advanced Peripheral Bus
CAN	Controller Area Network
DAC	Digital-to-Analog Converter
DMA	Direct Memory Access
GPIO	General Purpose Input/Output
JTAG	Joint Test Action Group
PLL	Phase-Locked Loop
SPI	Serial Peripheral Interface

## 4.2. Absolute maximum ratings

The maximum ratings are the limits to which the device can be subjected without permanently damaging the device. Note that the device is not guaranteed to operate properly at the maximum ratings. Exposure to the absolute maximum rating conditions for extended periods may affect device reliability.

**Table 4-2. Absolute maximum ratings<sup>(1)</sup>**

Symbol	Description	Min	Max	Unit
V <sub>DD</sub>	External digital supply voltage <sup>(2)</sup>	V <sub>SS</sub> - 0.3	V <sub>SS</sub> + 4	V
V <sub>DDA</sub>	External analog supply voltage <sup>(3)</sup>	V <sub>SSA</sub> - 0.3	V <sub>SSA</sub> + 4	V
V <sub>BAT</sub>	External battery supply voltage	V <sub>SS</sub> - 0.3	V <sub>SS</sub> + 4	V
V <sub>IN</sub>	Input voltage on 5V tolerant pin <sup>(4)</sup>	V <sub>SS</sub> - 0.3	V <sub>DD</sub> + 4	V
	Input voltage on other I/O	V <sub>SS</sub> - 0.3	V <sub>DD</sub> + 0.3	V
ΔV <sub>DDX</sub>	Variations between VDD power supply pins	—	50	mV
ΔV <sub>SSX</sub>	Variations between VSS ground pins	—	50	mV
I <sub>IO</sub>	Maximum current for each GPIO pin	—	±25	mA
∑I <sub>IO</sub>	Maximum current sunk/sourced by all GPIO pin	—	±100	
I <sub>DD</sub>	Maximum current into each VDD pin	—	100	
I <sub>SS</sub>	Maximum current into each Vss pin	—	100	
∑I <sub>DD</sub>	Total current into all VDD pins	—	200	
∑I <sub>SS</sub>	Total current into all VSS pins	—	200	
I <sub>INJ</sub>	Injected current on each GPIO pin <sup>(5)</sup>	—	-5/0	
∑I <sub>INJ</sub>	Total injected current on all GPIO pins <sup>(6)</sup>	—	±25	
T <sub>STG</sub>	Storage temperature	-65	150	°C
T <sub>J</sub>	Maximum junction temperature	—	125	°C

(1) Value guaranteed by design, not 100% tested in production.

(2) All power supply pins must be connected to the correct voltage range.

(3) It is recommended that VDD and VDDA are powered by the same source. The maximum difference between VDD and VDDA does not exceed 300 mV during power-up and operation.

(4) V<sub>IN</sub> maximum value cannot exceed 5.5 V.

(5) I<sub>INJ</sub> must never be exceeded. Negative injection on any analog input pins disturbs the analog performance of the device.

(6) When several inputs are submitted to a current injection, the maximum ∑I<sub>INJ</sub> is the absolute sum of the positive and negative injected currents (instantaneous values).

### 4.3. General operating conditions

The parameters are applicable to the full range of ambient temperature and voltage.

**Table 4-3. General operating conditions<sup>(1)</sup>**

Symbol	Description	Conditions	Min	Typ	Max	Unit
V <sub>DD</sub>	Digital supply voltage	—	2.6	3.3	3.6	V
V <sub>DDA</sub>	Analog supply voltage	Same as V <sub>DD</sub>	2.6	3.3	3.6	
V <sub>BAT</sub> <sup>(2)</sup>	Battery supply voltage	—	1.8	3.3	3.6	
V <sub>CORE</sub>	Core logic supply voltage powered by internal voltage regulator	LDOVS[2:0] =111	—	1.2	—	V
		LDOVS[2:0] =110	—	1.15	—	
		LDOVS[2:0] =101	—	1.1	—	
f <sub>HCLK</sub>	AHB clock frequency	—	—	—	200	MHz
f <sub>APB1</sub>	APB1 clock frequency	—	—	—	100	
f <sub>APB2</sub>	APB2 clock frequency	—	—	—	200	
P <sub>D</sub>	Power dissipation at T <sub>A</sub> = 85°C of LQFP100 <sup>(3)</sup>	—	—	—	717	mW
	Power dissipation at T <sub>A</sub> = 85°C of LQFP64 <sup>(3)</sup>	—	—	—	826	
	Power dissipation at T <sub>A</sub> = 85°C of QFN64 <sup>(3)</sup>	—	—	—	1290	
	Power dissipation at T <sub>A</sub> = 85°C of BGA64 <sup>(3)</sup>	—	—	—	509	
	Power dissipation at T <sub>A</sub> = 85°C of LQFP48 <sup>(3)</sup>	—	—	—	723	
	Power dissipation at T <sub>A</sub> = 85°C of QFN48 <sup>(3)</sup>	—	—	—	1190	
	Power dissipation at T <sub>A</sub> = 85°C of QFN32 <sup>(3)</sup>	—	—	—	974	
T <sub>A</sub>	Operating temperature range	—	-40	—	85	°C
T <sub>J</sub> <sup>(4)</sup>	Junction temperature	—	-40	—	125	°C

(1) Value guaranteed by design, not 100% tested in production.

(2) In the application which V<sub>BAT</sub> supply the backup domains, if the V<sub>BAT</sub> voltage drops below the minimum value, when V<sub>DD</sub> is powered on again, it is necessary to refresh the registers of backup domains and enable LXTAL again.

(3) If T<sub>A</sub> is lower, higher P<sub>D</sub> values are allowed as long as T<sub>J</sub> does not exceed T<sub>Jmax</sub>.

(4) The device junction temperature must be kept below maximum T<sub>J</sub>, otherwise it may cause permanent damage to the device.

Figure 4-1. Recommended power supply decoupling capacitors<sup>(1)(2)</sup>

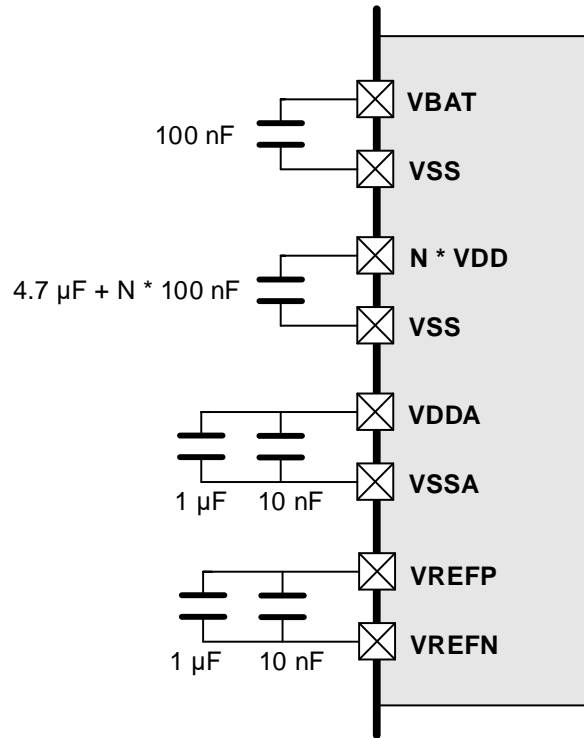

- (1) It is recommended to configure a 100nF capacitor for each VDD pin.
- (2) The V<sub>REFP</sub> and V<sub>REFN</sub> pins are only available on no less than 100-pin packages, or else the V<sub>REFP</sub> and V<sub>REFN</sub> pins are not available and internally connected to V<sub>D</sub> and V<sub>SSA</sub> pins.
- (3) All decoupling capacitors need to be as close as possible to the pins on the PCB board.

#### 4.4. Power supply requirement characteristics

Table 4-4. Power supply requirement characteristics<sup>(1)</sup>

Symbol	Description	Conditions	Min	Max	Unit
t <sub>VDD</sub> <sup>(1)</sup>	V <sub>DD</sub> /V <sub>D</sub> rise time rate	—	0	∞	μs/V
	V <sub>DD</sub> /V <sub>D</sub> fall time rate		20	∞	
f <sub>R(VDD/VDDA)</sub>	Allowable ripple frequency	V <sub>R(VDD/VDDA)</sub> ≤ 0.2 V <sub>DD</sub> /V <sub>D</sub>	—	10	MHz
		V <sub>R(VDD/VDDA)</sub> ≤ 0.08 V <sub>DD</sub> /V <sub>D</sub>	—	0.1	
		V <sub>R(VDD/VDDA)</sub> ≤ 0.06 V <sub>DD</sub> /V <sub>D</sub>	—	1	
ΔV <sub>DD</sub> /V <sub>D</sub> <sup>(2)</sup>	Allowable voltage change rising and falling gradient	When V <sub>DD</sub> /V <sub>D</sub> change exceeds V <sub>DD</sub> /V <sub>D</sub> ± 10%	1	—	ms/V

- (1) Value guaranteed by design, not 100% tested in production.
- (2) The ripple voltage must meet the allowable ripple frequency f<sub>R(VDD/VDDA)</sub> within the range between the V<sub>DD</sub>/V<sub>D</sub> upper limit (3.6 V) and lower limit (2.6 V). When the V<sub>DD</sub>/V<sub>D</sub> change exceeds V<sub>DD</sub>/V<sub>D</sub> ± 10%, the allowable voltage change rising and falling gradient ΔV<sub>DD</sub>/V<sub>D</sub> must be met.

Figure 4-2. Rise and fall gradient and ripple frequency characteristics

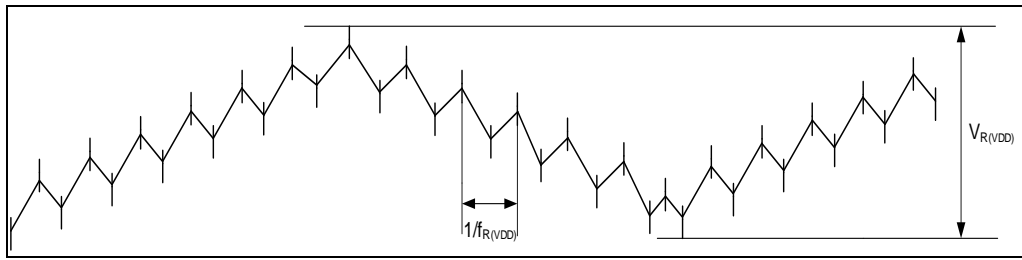

## 4.5. Start-up timings of Operating conditions

Table 4-5. Start-up timings of Operating conditions<sup>(1)(2)</sup>

Symbol	Description	Conditions	Min	Typ	Max	Unit
$t_{ST}^{(1)(2)}$	Start-up time	NWLD_CLK[1:0] = 00 Code area in FLASH = 256 KB	8.7	9.0	9.3	ms
		NWLD_CLK[1:0] = 01 Code area in FLASH = 256 KB	10.1	10.5	10.9	
		NWLD_CLK[1:0] = 10 Code area in FLASH = 256 KB	12.6	13	13.4	
		NWLD_CLK[1:0] = 11 Code area in FLASH = 256 KB	142.5	147	151.5	

(1) Value guaranteed by design, not 100% tested in production.

(2) After power-up, the start-up time is the time between the rising edge of NRST high and the first I/O instruction conversion in SystemInit function.

## 4.6. Wake-up times from power saving modes

**Table 4-6. Wake-up times from power saving modes<sup>(3)</sup>**

Symbol	Description	Conditions	Min	Typ	Max	Unit
$t_{\text{Sleep}}^{(1)}$	Wakeup from Sleep mode	—	—	2.1	—	$\mu\text{s}$
$t_{\text{Deep-sleep}}^{(1)}$	Wakeup from Deep-sleep mode (LDO On)	—	—	3.8	—	$\mu\text{s}$
	Wakeup from Deep-sleep mode (LDO in low power mode)	—	—	3.8	—	$\mu\text{s}$
$t_{\text{Standby}}^{(2)}$	Wakeup from Standby mode	NWLD_CLK[1:0] = 00 Code area in FLASH = 256 KB	8.7	9.0	9.3	ms
		NWLD_CLK[1:0] = 01 Code area in FLASH = 256 KB	10.1	10.5	10.9	
		NWLD_CLK[1:0] = 10 Code area in FLASH = 256 KB	12.6	13	13.4	
		NWLD_CLK[1:0] = 11 Code area in FLASH = 256 KB	142.5	147	151.5	

(1) Value guaranteed by sample, not 100% tested in production.

(2) Value guaranteed by design, not 100% tested in production.

(3) The wakeup time is measured from the wakeup event to the point at which the application code reads the first instruction under the below conditions:  $V_{\text{DD}} = V_{\text{DDA}} = 3.3\text{ V}$ , IRC8M = System clock = 8 MHz.

## 4.7. Power consumption

The power consumption is measured as described in [Figure 4 1. Power consumption measurement diagram](#). The current consumption values are derived from the tests powered by  $V_{\text{DD}} = V_{\text{DDA}}$  except BKP\_ONLY mode, while the current is  $I_{\text{SUM}}$ . In BKP\_ONLY mode, the RTC unit and LXTAL oscillator are powered by the  $V_{\text{BAT}}$ , while the current is  $I_{\text{BAT}}$ . Unless otherwise stated,  $V_{\text{DD}} = V_{\text{DDA}} = 3.3\text{ V}$  is applied to supply pins in typical current consumption columns, and  $V_{\text{DD}} = V_{\text{DDA}} = V_{\text{DD(MAX)}}$  is applied in maximum current consumption columns.

The MCU is configured under the following conditions:

- All I/O pins are in analog input mode
- All peripherals are disabled except when explicitly mentioned
- When the peripherals are enabled  $f_{\text{APB1}} = f_{\text{APB2}} / 2 = f_{\text{HCLK}} / 2$ .

Figure 4-3. Power consumption measurement diagram

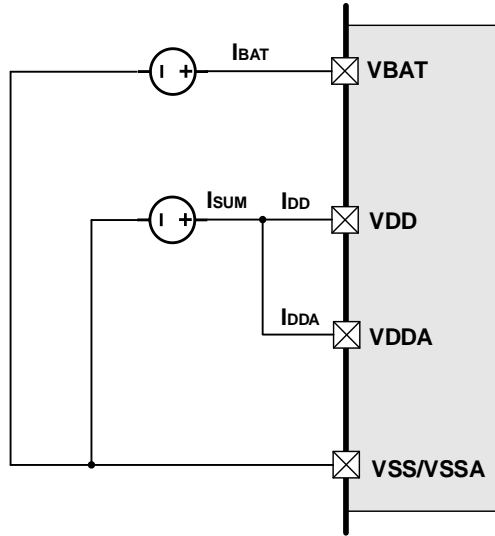

**Table 4-7. Power consumption in Run mode<sup>(1)</sup>**

Symbol	Description	Conditions					Typ <sup>(2)</sup>		Max <sup>(3)</sup>		Unit	
		Execute from	Peripherals	General	Vcore	f <sub>HCLK</sub>	25°C	85°C	25°C	85°C		
I <sub>SUM</sub>	Sum of supply current from VDD and VDDA (Run mode)	FLASH	All disabled	External Clock(HXT AL = 8 MHz, PLL on, System clock = f <sub>HCLK</sub> )	1.2 V	200 MHz	21.3	23.3	TBD	TBD	mA	
						168 MHz	17.8	19.2	TBD	TBD		
						108 MHz	12.7	14.1	TBD	TBD		
						72 MHz	8.7	10.1	TBD	TBD		
						36 MHz	5.4	6.5	TBD	TBD		
						8 MHz	2.6	3.8	TBD	TBD		
				1.1 V	200 MHz	19.1	20.3	TBD	TBD			
					168 MHz	16.4	12.9	TBD	TBD			
					108 MHz	11.8	17.5	TBD	TBD			
					Internal Clock(IRC 8M = 8 MHz, PLL on, System clock = f <sub>HCLK</sub> )	1.2 V	200 MHz	19.8	21.7	TBD		TBD
							168 MHz	17.1	18.5	TBD		TBD
							108 MHz	11.1	12.5	TBD		TBD
			72 MHz	7.2			8.5	TBD	TBD			
			1.1 V	36 MHz	3.9	5.1	TBD	TBD				
					8 MHz	1.1	2.2	TBD	TBD			
					200 MHz	17.6	18.8	TBD	TBD			
			1.1 V	108 MHz	14.5	15.9	TBD	TBD				
					10.3	11.3	TBD	TBD				
All enabled	External Clock(HXT AL = 8 MHz, PLL on, System	1.2 V	200 MHz	42.3	44.6	TBD	TBD					
		1.1 V	200 MHz	37.8	39.5	TBD	TBD					

Symbol	Description	Conditions					Typ <sup>(2)</sup>		Max <sup>(3)</sup>		Unit		
		Execute from	Peripherals	General	Vcore	f <sub>HCLK</sub>	25°C	85°C	25°C	85°C			
				clock = f <sub>HCLK</sub> )									
				Internal Clock(IRC 8M = 8 MHz, PLL on, System clock = f <sub>HCLK</sub> )	1.2 V	200 MHz	40.7	42.9	TBD	TBD			
					1.1 V	200 MHz	36.2	37.9	TBD	TBD			
		SRAM <sup>(5)</sup>	All disabled	External Clock(HXTAL = 8 MHz, PLL on, System clock = f <sub>HCLK</sub> )	1.2 V	200 MHz	20.6	22.2	TBD	TBD			
						168 MHz	18.6	20.0	TBD	TBD			
						108 MHz	13.2	14.6	TBD	TBD			
						72 MHz	9.1	10.4	TBD	TBD			
						36 MHz	5.6	6.8	TBD	TBD			
						8 MHz	2.7	3.8	TBD	TBD			
							1.1 V	200 MHz	19.9	21.1	TBD	TBD	
								168 MHz	17.1	18.2	TBD	TBD	
								108 MHz	12.2	13.3	TBD	TBD	
							1.2 V	200 MHz	19.1	20.7	TBD	TBD	
								168 MHz	17.9	19.3	TBD	TBD	
								108 MHz	11.6	12.9	TBD	TBD	
								72 MHz	7.7	8.8	TBD	TBD	
								36 MHz	4.1	5.3	TBD	TBD	
				8 MHz	1.1	2.3		TBD	TBD				

Symbol	Description	Conditions					Typ <sup>(2)</sup>		Max <sup>(3)</sup>		Unit
		Execute from	Peripherals	General	Vcore	f <sub>HCLK</sub>	25°C	85°C	25°C	85°C	
				clock = f <sub>HCLK</sub> )	1.1 V	200 MHz	18.4	19.5	TBD	TBD	
						168 MHz	15.4	16.5	TBD	TBD	
						108 MHz	10.7	11.8	TBD	TBD	
		All enabled		External Clock(HXT AL = 8 MHz, PLL on, System clock = f <sub>HCLK</sub> )	1.2 V	200 MHz	41.2	43.4	TBD	TBD	
					1.1 V	200 MHz	37.8	39.4	TBD	TBD	
				Internal Clock(IRC 8M = 8 MHz, PLL on, System clock = f <sub>HCLK</sub> )	1.2 V	200 MHz	39.6	41.8	TBD	TBD	
1.1 V	200 MHz	36.3	37.8		TBD	TBD					

(1) During power consumption test, GPIO needs to be configure as Analog Input mode.

(2) Value guaranteed by sample, not 100% tested in production.

(3) Value guaranteed by characterization, not 100% tested in production.

**Table 4-8. Power consumption in Run mode with different codes<sup>(1) (2)</sup>**

Symbol	Description	Conditions				Typ	Unit	Typ	Unit
		Execute from	General	Vcore	Code				
I <sub>SUM</sub>	Sum of supply current from	FLASH		1.2 V	Coremark	25.3	mA	127	μA /MHz

Symbol	Description	Conditions				Typ	Unit	Typ	Unit
		Execute from	General	Vcore	Code				
	VDD and VDDA (Run mode)		HXTAL = 8 MHz, PLL on, System clock = 200 MHz, f <sub>HCLK</sub> = 200 MHz All peripherals disabled	1.1 V		23.5		118	
		SRAM <sup>(3)</sup>	HXTAL = 8 MHz, PLL on, System clock = 200 MHz, f <sub>HCLK</sub> = 200 MHz All peripherals disabled	1.2 V	Coremark	22.6		113	
				1.1 V		21.2		106	

- (1) Value guaranteed by sample, not 100% tested in production.  
(2) During power consumption test, GPIO needs to be configure as Analog Input mode.  
(3) Code compiled with high optimization for space in SRAM.

**Table 4-9. Power consumption in Sleep mode<sup>(1)</sup>**

Symbol	Description	Conditions				Typ <sup>(2)</sup>		Max <sup>(3)</sup>		Unit
		peripherals	General	Vcore	f <sub>HCLK</sub>	25°C	85°C	25°C	85°C	
I <sub>SUM</sub>	Sum of supply current from VDD and VDDA (Sleep mode)	All disabled	External Clock(HXTAL = 8 MHz, PLL on, System clock = f <sub>HCLK</sub> , CPU clock off)	1.2 V	200 MHz	7.6	9.1	TBD	TBD	mA
					168 MHz	7.1	8.3	TBD	TBD	
					108 MHz	5.8	6.9	TBD	TBD	
					72 MHz	4.2	5.3	TBD	TBD	
					36 MHz	3.1	4.2	TBD	TBD	
					8 MHz	2.1	3.2	TBD	TBD	
			Internal Clock(IRC8M = 8 MHz, PLL	1.2 V	200 MHz	6.4	7.7	TBD	TBD	
					168 MHz	5.3	6.5	TBD	TBD	
					108 MHz	5.3	6.3	TBD	TBD	
					200 MHz	6.4	7.7	TBD	TBD	
					168 MHz	5.3	6.5	TBD	TBD	
					108 MHz	3.6	4.7	TBD	TBD	

Symbol	Description	Conditions				Typ <sup>(2)</sup>		Max <sup>(3)</sup>		Unit				
		peripherals	General	Vcore	f <sub>HCLK</sub>	25°C	85°C	25°C	85°C					
			on, System clock = f <sub>HCLK</sub> , CPU clock off)		72 MHz	2.7	3.7	TBD	TBD					
					36 MHz	1.5	2.7	TBD	TBD					
					8 MHz	0.5	1.7	TBD	TBD					
					200 MHz	5.8	6.8	TBD	TBD					
					168 MHz	4.9	5.8	TBD	TBD					
					108 MHz	3.9	4.8	TBD	TBD					
		All enabled	External Clock(HXTAL = 8 MHz, PLL on, System clock = f <sub>HCLK</sub> , CPU clock off)	1.2 V	200 MHz	30.0	31.8	TBD	TBD					
						1.1 V	200 MHz	27.7	29.2		TBD	TBD		
								1.2 V	200 MHz		28.5	30.2	TBD	TBD
											1.1 V	200 MHz	26.2	27.6

(1) During power consumption test, GPIO needs to be configure as Analog Input mode.

(2) Value guaranteed by sample, not 100% tested in production.

(3) Value guaranteed by characterization, not 100% tested in production.

**Table 4-10. Power consumption in Deep-sleep mode<sup>(1)</sup>**

Symbol	Description	Conditions			Typ <sup>(2)</sup>		Max <sup>(3)</sup>		Unit
		General	V <sub>CORE</sub>	V <sub>DD</sub>	25°C	85°C	25°C	85°C	
I <sub>SUM</sub>	Sum of supply current from VDD and VDDA (Deep-sleep mode)	LDO in normal power and normal driver mode,	1.2 V	2.6V	224.2	1314.6	TBD	TBD	μA
				3.3V	225.1	1319.0	TBD	TBD	
				3.6V	225.7	1320.0	TBD	TBD	

Symbol	Description	Conditions			Typ <sup>(2)</sup>		Max <sup>(3)</sup>		Unit
		General	V <sub>CORE</sub>	V <sub>DD</sub>	25°C	85°C	25°C	85°C	
		IRC40K off, RTC off	1.1 V	2.6V	189.7	1096.1	TBD	TBD	
				3.3V	190.4	1099.0	TBD	TBD	
				3.6V	190.9	1100.2	TBD	TBD	
			0.95 V	2.6V	153.7	854.8	TBD	TBD	
				3.3V	154.4	857.3	TBD	TBD	
				3.6V	154.9	858.8	TBD	TBD	
		LDO in normal power and low driver mode, IRC40K off, RTC off	1.2 V	2.6V	171.2	1251.1	TBD	TBD	
				3.3V	171.7	1254.3	TBD	TBD	
				3.6V	172.2	1255.9	TBD	TBD	
			1.1 V	2.6V	139.1	1042.8	TBD	TBD	
				3.3V	139.8	1045.7	TBD	TBD	
				3.6V	140.4	1047.2	TBD	TBD	
			0.95 V	2.6V	102.9	802.4	TBD	TBD	
				3.3V	103.5	804.5	TBD	TBD	
				3.6V	104.0	806.7	TBD	TBD	
		LDO in low power and normal driver mode, IRC40K off, RTC off	1.2 V	2.6V	196.8	1276.5	TBD	TBD	
				3.3V	197.5	1279.7	TBD	TBD	
				3.6V	198.1	1281.5	TBD	TBD	
			1.1 V	2.6V	165.0	1068.4	TBD	TBD	
				3.3V	165.6	1070.9	TBD	TBD	
				3.6V	166.1	1072.6	TBD	TBD	
			0.95 V	2.6V	128.3	827.7	TBD	TBD	
				3.3V	129.1	829.3	TBD	TBD	
				3.6V	129.5	831.4	TBD	TBD	
LDO in low power and low driver	1.2 V	2.6V	145.1	1238.4	TBD	TBD			
		3.3V	145.6	1241.5	TBD	TBD			

Symbol	Description	Conditions			Typ <sup>(2)</sup>		Max <sup>(3)</sup>		Unit	
		General	V <sub>CORE</sub>	V <sub>DD</sub>	25°C	85°C	25°C	85°C		
		mode, IRC40K off, RTC off	1.1 V	3.6V	146.0	1246.0	TBD	TBD		
				2.6V	113.2	1027.5	TBD	TBD		
				3.3V	113.8	1029.8	TBD	TBD		
				3.6V	114.3	1030.9	TBD	TBD		
				0.95 V	2.6V	75.8	783.4	TBD		TBD
					3.3V	76.5	785.7	TBD		TBD
		3.6V	76.9		787.1	TBD	TBD			

(1) During power consumption test, GPIO needs to be configure as Analog Input mode.

(2) Value guaranteed by sample, not 100% tested in production.

(3) Value guaranteed by characterization, not 100% tested in production.

**Table 4-11. Power consumption in Standby mode**

Symbol	Description	Conditions		Typ <sup>(1)</sup>		Max <sup>(2)</sup>		Unit
		General	V <sub>DD</sub>	25°C	85°C	25°C	85°C	
I <sub>SUM</sub>	Sum of supply current from VDD and VDDA (Standby mode)	LXTAL off, IRC40K on, RTC on	2.6V	3.0	4.5	TBD	TBD	μA
			3.3V	3.7	6.1	TBD	TBD	
			3.6V	4.2	7.1	TBD	TBD	
		LXTAL off, IRC40K on, RTC off	2.6V	2.8	4.3	TBD	TBD	
			3.3V	3.5	5.8	TBD	TBD	
			3.6V	3.9	6.8	TBD	TBD	
		LXTAL off, IRC40K off, RTC off	2.6V	2.2	3.8	TBD	TBD	
			3.3V	2.8	5.2	TBD	TBD	
			3.6V	3.2	6.2	TBD	TBD	

(1) Value guaranteed by sample, not 100% tested in production.

(2) Value guaranteed by characterization, not 100% tested in production.

**Table 4-12. Power consumption in BKP\_ONLY mode**

Symbol	Description	Conditions		Typ <sup>(1)</sup>		Max <sup>(2)</sup>		Unit
		General	V <sub>BAT</sub>	25°C	85°C	25°C	85°C	
I <sub>BAT</sub>	LXTAL+RTC current from VBAT (BKP_ONLY mode)	VDD off, LXTAL on with external crystal, RTC on, LXTAL High driving	1.8V	1.7	2.1	TBD	TBD	μA
			2.6V	1.8	2.2	TBD	TBD	
			3.3V	1.9	2.4	TBD	TBD	
			3.6V	2.0	2.5	TBD	TBD	
		VDD off, LXTAL on with external crystal, RTC on, LXTAL Medium High driving	1.8V	1.3	1.6	TBD	TBD	
			2.6V	1.4	1.7	TBD	TBD	
			3.3V	1.5	1.8	TBD	TBD	
			3.6V	1.6	2.0	TBD	TBD	
		VDD off, LXTAL on with external crystal, RTC on, LXTAL Medium Low driving	1.8V	0.8	1.0	TBD	TBD	
			2.6V	0.9	1.2	TBD	TBD	
			3.3V	1.0	1.3	TBD	TBD	
			3.6V	1.1	1.5	TBD	TBD	
		VDD off, LXTAL on with external crystal, RTC on, LXTAL Low driving	1.8V	0.7	0.9	TBD	TBD	
			2.6V	0.8	1.0	TBD	TBD	
			3.3V	0.9	1.1	TBD	TBD	
			3.6V	1.0	1.3	TBD	TBD	

(1) Value guaranteed by sample, not 100% tested in production.

(2) Value guaranteed by characterization, not 100% tested in production.

The current consumption of the on-chip peripherals is given in the following table. To avoid adding the CPU dynamic power consumption to the peripheral power consumption, the MCU needs to enter sleep mode to stop the CPU operation during current measurement. The MCU is configured under the following conditions:

- All I/O pins are in analog input mode
- The given value is in the table calculated by measuring the difference of the current consumptions:
  - The target peripheral is clocked on and enters sleep mode
  - All peripherals are clocked off and enter sleep mode

The power consumption of the digital part of the on-chip peripherals is given in the following table. The power consumption of the analog part of the peripherals (where applicable) is indicated in each related section of the datasheet.

The values in the table are equal to the peripheral current divided by the clock frequency of the corresponding BUS.

**Table 4-13. Peripheral current consumption characteristics<sup>(1)</sup>**

Peripherals		Typical consumption	Unit
APB1	CTC	0.061	μA/MHz
	DAC	0.084	
	PMU	1.794	
	BKP	2.274	
	I2C1	0.463	
	I2C0	0.477	
	UART4	0.308	
	UART3	0.309	
	USART2	0.515	
	USART1	0.479	
	SPI2	0.413	
	SPI1	0.408	
	WWDGT	0.053	
	TIMER16	2.033	
	TIMER6	0.218	
	TIMER5	0.196	
	TIMER4	1.687	
	TIMER3	1.678	
TIMER2	1.610		
TIMER1	1.855		
APB2	TIMER15	4.655	
	SYSCFG	0.004	
	TRIGSEL	0.346	
	CAN1	2.925	
	CAN0	3.120	

Peripherals		Typical consumption	Unit
	USART0	2.108	
	TIMER7	8.744	
	SPI0	0.609	
	TIMER0	8.763	
	ADC2	1.008	
	ADC1	0.923	
	ADC0	0.956	
	GPIOE	0.752	
	GIPOD	0.757	
	GPIOC	0.729	
	GPIOB	0.766	
	GPIOA	0.722	
	AF	0.046	
AHB	FMC	10.152	
	SRAM	1.064	
	USBFS	5.236	
	CRC	0.180	
	DMA1	1.162	
	DMA0	1.454	
	DMAMUX	2.043	

(1) Value guaranteed by sample, not 100% tested in production.

## 4.8. EMC characteristics

System level ESD (Electrostatic discharge, according to IEC 61000-4-2) and EFT (Electrical Fast Transient/burst, according to IEC 61000-4-4) testing result is given in the [Table 4-14. System level ESD and EFT characteristics](#)<sup>(1)</sup>. System level ESD is for end-customer operation, it includes ESD field events on system level occur in an unprotected area (outside EPA). System level ESD protection necessary to satisfy higher ESD levels.

**Table 4-14. System level ESD and EFT characteristics**<sup>(1)</sup>

Symbol	Description	Conditions	Package	Class	Level
V <sub>ESD</sub>	Contact / Air mode high voltage stressed on few special I/O pins	V <sub>DD</sub> / V <sub>DDA</sub> = 3.3 V, T <sub>J</sub> = 25 °C, f <sub>HCLK</sub> = 200 MHz IEC 61000-4-2	LQFP100	CD 8KV AD 15KV	4A
V <sub>EFT</sub>	Fast transient high voltage burst stressed on Power and GND	V <sub>DD</sub> = 3.3 V, T <sub>J</sub> = 25 °C, f <sub>HCLK</sub> = 200 MHz IEC 61000-4-4	LQFP100	4KV	4A

(1) Value guaranteed by characterization, not 100% tested in production.

EMI (Electromagnetic Interference) emission test result is given in the [Table 4-15. EMI characteristics](#). The electromagnetic field emitted by the device are monitored while an

application, executing EEMBC code, is running. The test is compliant with SAE J1752-3:2017 standard which specifies the test board and the pin loading.

**Table 4-15. EMI characteristics<sup>(1)</sup>**

Symbol	Description	Conditions	Package	Max vs. [f <sub>HXTAL</sub> /f <sub>HCLK</sub> ]			Unit
				8/200 MHz			
				0.1-30MHz	30-130MHz	130MHz-1GHz	
S <sub>EMI</sub>	Peak level	V <sub>DD</sub> = 3.6 V, T <sub>J</sub> = 25 °C, f <sub>HCLK</sub> = 200 MHz, conforms to SAE J1752-3:2017	LQFP100	-5.95	9.81	9.48	dBμV

(1) Value guaranteed by characterization, not 100% tested in production.

Component level ESD include HBM (Human body model, according to ANSI/ESDA/JEDEC JS-001) and CDM (ANSI/ESDA/JEDEC JS-002), that ESD field events during manufacturing in an ESD protected area, such as PCB assembly/repair, IC assembly/test and Fab environment. The ESD protected area (EPA) has many measures, for instance ESD protective packaging, grounding person wrist strap to ground (or flooring/footwear), grounded work surface and ionizer.

Static latch-up (LU, according to JEDEC78) test is based on the two measurement methods, I/O current injection value (I-test) and power supply over-voltage value.

**Table 4-14. Component level ESD and latch-up characteristics<sup>(1)</sup>**

Symbol	Description	Conditions	Package	Max	Unit	Level
V <sub>HBM</sub>	Human body model electrostatic discharge voltage (Any pin combination)	T <sub>A</sub> = 25 °C; JS-001-2017	LQFP100	4000	V	3A
V <sub>CDM</sub>	Charge device model electrostatic discharge voltage (All pins)	T <sub>A</sub> = 25 °C; JS-002-2018	LQFP100	1000	V	C3
LU	I-test	T <sub>A</sub> = 25 °C; JESD78	LQFP100	±200	mA	Class II.A
	V <sub>supply</sub> over voltage			5.4	V	

(1) Value guaranteed by characterization, not 100% tested in production.

## 4.9. Power supply supervisor characteristics

**Table 4-16. Power supply supervisor characteristics<sup>(1)</sup>**

Symbol	Description	Conditions	Min	Typ	Max	Unit
V <sub>LVD</sub>	Low voltage Detector level selection	LVDT[2:0] = 000(rising edge)	—	2.14	—	V
		LVDT[2:0] = 000(falling edge)	—	2.04	—	
		LVDT[2:0] = 001(rising edge)	—	2.28	—	
		LVDT[2:0] = 001(falling edge)	—	2.18	—	

Symbol	Description	Conditions	Min	Typ	Max	Unit
		LVDT[2:0] = 010(rising edge)	—	2.42	—	
		LVDT[2:0] = 010(falling edge)	—	2.32	—	
		LVDT[2:0] = 011(rising edge)	—	2.56	—	
		LVDT[2:0] = 011(falling edge)	—	2.46	—	
		LVDT[2:0] = 100(rising edge)	—	2.7	—	
		LVDT[2:0] = 100(falling edge)	—	2.6	—	
		LVDT[2:0] = 101(rising edge)	—	2.84	—	
		LVDT[2:0] = 101(falling edge)	—	2.74	—	
		LVDT[2:0] = 110(rising edge)	—	2.98	—	
		LVDT[2:0] = 110(falling edge)	—	2.88	—	
		LVDT[2:0] = 111(rising edge)	—	3.12	—	
		LVDT[2:0] = 111(falling edge)	—	3.02	—	
V <sub>HYST(LVD)</sub>	LVD hystersis	—	—	100	—	mV
V <sub>POR</sub>	Power on reset threshold	—	—	2.4	—	V
V <sub>PDR</sub>	Power down reset threshold	PDRVS = 0	—	2.35	—	V
		PDRVS = 1	—	1.8	—	
V <sub>HYST(POR_PDR)</sub>	Hysteresis of POR and PDR	PDRVS = 0	—	50	—	mV
		PDRVS = 1	—	600	—	
t <sub>RST(TEMPO)</sub>	Reset temporization	—	—	2	—	ms
V <sub>AVD</sub>	Analog voltage detector for V <sub>D</sub> DA level selection	VAVDVC[1:0] = 00(rising edge)	—	2.4	—	V
		VAVDVC[1:0] = 00(falling edge)	—	2.3	—	
		VAVDVC[1:0] = 01(rising edge)	—	2.6	—	
		VAVDVC[1:0] = 01(falling edge)	—	2.5	—	
		VAVDVC[1:0] = 10(rising edge)	—	2.8	—	
		VAVDVC[1:0] = 10(falling edge)	—	2.7	—	
		VAVDVC[1:0] = 11(rising edge)	—	3.0	—	
		VAVDVC[1:0] = 11(falling edge)	—	2.9	—	
V <sub>hyst_AV</sub> D	Hysteresis of V <sub>D</sub> DA voltage detector	—	—	100	—	mV

Symbol	Description	Conditions	Min	Typ	Max	Unit
V <sub>OVD</sub>	Analog voltage detector for V <sub>CORE</sub> over level selection	VOVDVC[1:0] = 00(rising edge)	—	1.25	—	V
		VOVDVC[1:0] = 00(falling edge)	—	1.225	—	
		VOVDVC[1:0] = 01(rising edge)	—	1.30	—	
		VOVDVC[1:0] = 01(falling edge)	—	1.275	—	
		VOVDVC[1:0] = 10(rising edge)	—	1.35	—	
		VOVDVC[1:0] = 10(falling edge)	—	1.325	—	
		VOVDVC[1:0] = 11(rising edge)	—	1.40	—	
		VOVDVC[1:0] = 11(falling edge)	—	1.375	—	
V <sub>hyst_OVD</sub>	Hysteresis of V <sub>CORE</sub> over voltage detector	—	—	25	—	mV
V <sub>UVD</sub>	Analog voltage detector for V <sub>CORE</sub> under level selection	VUVDVC[1:0] = 00(rising edge)	—	1.075	—	V
		VUVDVC[1:0] = 00(falling edge)	—	1.05	—	
		VUVDVC[1:0] = 01(rising edge)	—	0.975	—	
		VUVDVC[1:0] = 01(falling edge)	—	0.95	—	
		VUVDVC[1:0] = 1x(rising edge)	—	0.875	—	
		VUVDVC[1:0] = 1x(falling edge)	—	0.85	—	
V <sub>hyst_UVD</sub>	Hysteresis of V <sub>CORE</sub> voltage under detector	—	—	25	—	mV

(1) Value guaranteed by design, not 100% tested in production.

## 4.10. External clock characteristics

Figure 4-4. Internal structure diagram of OSCIN and OSCOUT pin

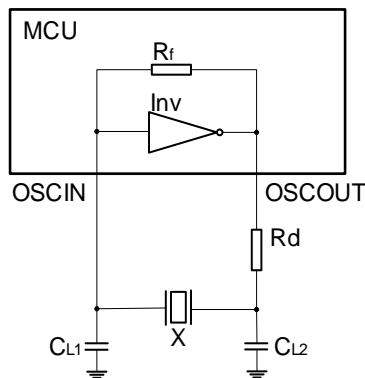

It is strongly recommended to measure the oscillation allowance (negative resistance) in the final target system (layout) to determine which load capacitors will best tune their resonator/crystal to the microcontroller device for optimum start-up and operation over

temperature/voltage extremes.

**Table 4-17. High speed external clock (HXTAL) generated from a crystal/ceramic characteristics<sup>(1)</sup>**

Symbol	Description	Conditions	Min	Typ	Max	Unit
$f_{\text{HXTAL}}^{(1)}$	Crystal or ceramic frequency	$2.6 \text{ V} \leq V_{\text{DD}} \leq 3.6 \text{ V}$	4	32	40	MHz
$R_{\text{F}}$	Feedback resistor	—	—	400	—	k $\Omega$
$C_{\text{HXTAL}}^{(2)}$	Recommended matching capacitance on OSCIN and OSCOUT	—	—	20	30	pF
Duty <sub>HXTAL</sub>	Crystal or ceramic duty cycle	—	30	—	70	%
$g_{\text{m}}^{(3)}$	Oscillator transconductance	Startup	—	32	—	mA/V
$I_{\text{DD}}(\text{HXTAL})$	Crystal or ceramic operating current	—	—	1.5	—	mA
$t_{\text{ST}}(\text{HXTAL})$	Crystal or ceramic startup time	—	—	1	—	ms

(1) Value guaranteed by design, not 100% tested in production.

(2)  $C_{\text{HXTAL1}} = C_{\text{HXTAL2}} = 2 * (C_{\text{LOAD}} - C_{\text{S}})$ , For  $C_{\text{HXTAL1}}$  and  $C_{\text{HXTAL2}}$ , it is recommended matching capacitance on OSCIN and OSCOUT. For  $C_{\text{LOAD}}$ , it is crystal/ceramic load capacitance, provided by the crystal or ceramic manufacturer. For  $C_{\text{S}}$ , it is PCB and MCU pin stray capacitance.

(3) More details about  $g_{\text{m}}$  could be found in [AN052 GD32 MCU Resonator-Based Clock Circuits](#).

**Table 4-18. High speed external clock characteristics (HXTAL in bypass mode)<sup>(1)</sup>**

Symbol	Description	Conditions	Min	Typ	Max	Unit
$f_{\text{HXTAL\_ext}}$	External clock source or oscillator frequency	—	1	—	50	MHz
$V_{\text{H}}(\text{HXTAL})$	OSCIN input pin high level voltage	—	$0.7 * V_{\text{DD}}$	—	$V_{\text{DD}}$	V
$V_{\text{L}}(\text{HXTAL})$	OSCIN input pin low level voltage		$V_{\text{SS}}$	—	$0.3 * V_{\text{SS}}$	V
$t_{\text{H/L}}(\text{HXTAL})$	OSCIN high or low time	—	5	—	—	ns
$t_{\text{R/F}}(\text{HXTAL})$	OSCIN rise or fall time	—	—	—	10	ns
$C_{\text{IN}}$	OSCIN input capacitance	—	—	5	—	pF
Duty <sub>HXTAL</sub>	Duty cycle	—	30	—	70	%

(1) Value guaranteed by design, not 100% tested in production.

**Figure 4-5. High-speed external clock source AC timing diagram**

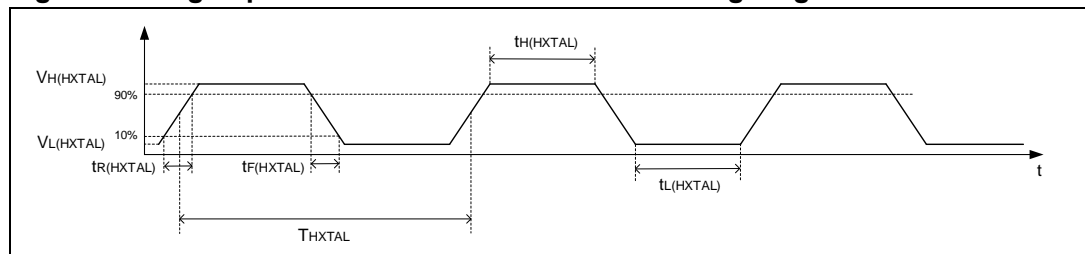

**Table 4-19. Low speed external clock (LXTAL) generated from a crystal/ceramic characteristics<sup>(1)</sup>**

Symbol	Description	Conditions	Min	Typ	Max	Unit
$f_{LXTAL}$	Crystal or ceramic frequency	—	—	32.768	—	kHz
$C_{LXTAL}^{(2)}$	Recommended matching capacitance on OSC32IN and OSC32OUT	—	—	15	—	pF
Duty <sub>LXTA</sub>	Crystal or ceramic duty cycle	—	30	—	70	%
GM <sup>(4)</sup>	Oscillator transconductance	LXTALDRI[1:0] = 00	—	4.6	—	μA/V
		LXTALDRI[1:0] = 01	—	6.9	—	
		LXTALDRI[1:0] = 10	—	13	—	
		LXTALDRI[1:0] = 11	—	20	—	
I <sub>DD(LXTAL)</sub>	Crystal or ceramic operating current	LXTALDRI[1:0] = 00	—	0.5	—	μA
		LXTALDRI[1:0] = 01	—	0.6	—	
		LXTALDRI[1:0] = 10	—	0.9	—	
		LXTALDRI[1:0] = 11	—	1.2	—	
t <sub>ST(LXTAL)</sub> <sup>(3)</sup>	Crystal or ceramic startup time	V <sub>DD</sub> =3.3V	—	2	—	s

(1) Value guaranteed by design, not 100% tested in production.

(2)  $C_{LXTAL1} = C_{LXTAL2} = 2 * (C_{LOAD} - C_S)$ , For  $C_{LXTAL1}$  and  $C_{LXTAL2}$ , it is recommended matching capacitance on OSC32IN and OSC32OUT. For  $C_{LOAD}$ , it is crystal/ceramic load capacitance, provided by the crystal or ceramic manufacturer. For  $C_S$ , it is PCB and MCU pin stray capacitance.

(3) t<sub>ST(LXTAL)</sub> is the startup time measured from the moment it is enabled (by software) to the 32.768 kHz oscillator stabilization flags is SET. This value varies significantly with the crystal manufacturer.

(4) More details about g<sub>m</sub> could be found in [AN052 GD32 MCU Resonator-Based Clock Circuits](#).

**Table 4-20. Low speed external user clock characteristics (LXTAL in bypass mode)**

(1)

Symbol	Description	Conditions	Min	Typ	Max	Unit
$f_{LXTAL\_EXT}$	External clock source or oscillator frequency	—	—	32.768	1000	kHz
V <sub>H(LXTAL)</sub>	OSC32IN input pin high level voltage	—	0.7*V <sub>DD</sub>	—	V <sub>DD</sub>	V
V <sub>L(LXTAL)</sub>	OSC32IN input pin low level voltage	—	V <sub>SS</sub>	—	0.3*V <sub>SS</sub>	
t <sub>H/L(LXTAL)</sub>	OSC32IN high or low time	—	450	—	—	ns
t <sub>R/F(LXTAL)</sub>	OSC32IN rise or fall time	—	—	—	50	
C <sub>IN</sub>	OSC32IN input capacitance	—	—	5	—	pF
Duty <sub>LXTAL</sub>	Duty cycle	—	30	—	70	%

(1) Value guaranteed by design, not 100% tested in production.

**Figure 4-6. Low-speed external clock source AC timing diagram**

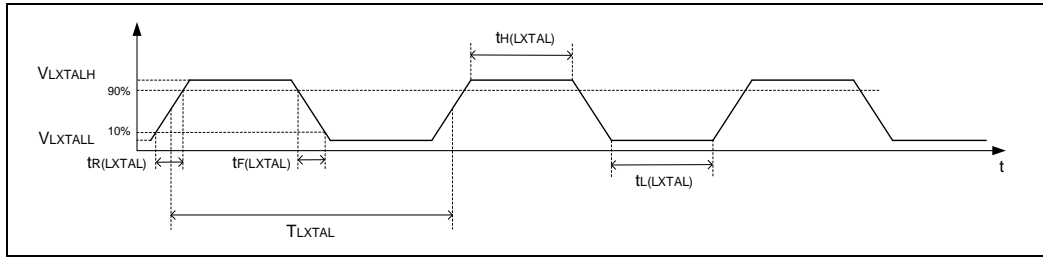

**Figure 4-7. Recommended external OSCIN and OSCOUT pins circuit for crystal**

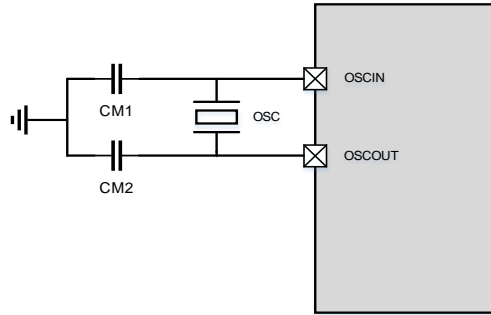

**Figure 4-8. Recommended external OSCIN and OSCOUT pins circuit for oscillator**

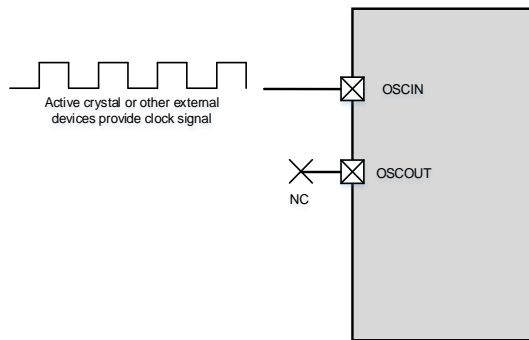

## 4.11. Internal clock characteristics

**Table 4-21. High speed internal clock (IRC48M) characteristics**

Symbol	Description	Conditions	Min	Typ	Max	Unit
$f_{IRC48M}^{(1)}$	High Speed Internal Oscillator (IRC48M) frequency	—	—	48	—	MHz
$Drift_{IRC48M}$	IRC48M oscillator Frequency drift, Factory-trimmed	$V_{DD} = V_{DDA} = 3.3\text{ V}$ , $T_A = -40\text{ }^{\circ}\text{C} \sim +85\text{ }^{\circ}\text{C}$	-2 <sup>(2)</sup>	—	+2 <sup>(2)</sup>	%
		$V_{DD} = V_{DDA} = 3.3\text{ V}$ , $T_A = 25\text{ }^{\circ}\text{C}$	-2	—	2	%
	IRC48M oscillator Frequency drift, User trimming step <sup>(1)</sup>	—	—	0.13	—	%
$Duty_{IRC48M}^{(1)}$	IRC48M oscillator duty cycle	—	45	50	55	%
$I_{DDA(IRC48M)}^{(1)}$	IRC48M oscillator operating current	$f_{IRC48M} = 48\text{ MHz}$	—	342	450	$\mu\text{A}$
$t_{ST(IRC48M)}^{(1)}$	IRC48M oscillator startup time	$f_{IRC48M} = 48\text{ MHz}$	0.8	—	1.8	$\mu\text{s}$

(1) Value guaranteed by design, not 100% tested in production.

(2) Value guaranteed by characterization, not 100% tested in production.

**Table 4-22. High speed internal clock (IRC8M) characteristics**

Symbol	Description	Conditions	Min	Typ	Max	Unit
$f_{IRC8M}^{(1)}$	High Speed Internal Oscillator (IRC8M) frequency	—	—	8	—	MHz
$Drift_{IRC8M}$	IRC8M oscillator Frequency drift, Factory-trimmed	$V_{DD} = V_{DDA} = 3.3\text{ V}$ , $T_A = -40\text{ }^{\circ}\text{C} \sim +85\text{ }^{\circ}\text{C}$	-2 <sup>(2)</sup>	—	+2 <sup>(2)</sup>	%
		$V_{DD} = V_{DDA} = 3.3\text{ V}$ , $T_A = 25\text{ }^{\circ}\text{C}$	-1	—	1	%
	IRC8M oscillator Frequency drift, User trimming step <sup>(1)</sup>	—	—	0.5	—	%
$Duty_{IRC8M}^{(1)}$	IRC8M oscillator duty cycle	—	45	50	55	%
$I_{DDA(IRC8M)}^{(1)}$	IRC8M oscillator operating current	$f_{IRC8M} = 8\text{ MHz}$	—	66	88	$\mu\text{A}$
$t_{ST(IRC8M)}^{(1)}$	IRC8M oscillator startup time	$f_{IRC8M} = 8\text{ MHz}$	1.4	—	2.8	$\mu\text{s}$

(1) Value guaranteed by design, not 100% tested in production.

(2) Value guaranteed by characterization, not 100% tested in production.

**Table 4-23. Low speed internal clock (IRC40K) characteristics**

Symbol	Description	Conditions	Min	Typ	Max	Unit
$f_{IRC40K}^{(1)}$	Low Speed Internal oscillator (IRC40K) frequency	—	—	40	—	kHz
$ACC_{IRC40K}$	IRC40K oscillator Frequency accuracy, Factory-trimmed	$V_{DD} = V_{DDA} = 3.3\text{ V}$ , $T_A = -40\text{ }^{\circ}\text{C} \sim +85\text{ }^{\circ}\text{C}$	-5.5 <sup>(2)</sup>	—	+5.5 <sup>(2)</sup>	%
		$V_{DD} = V_{DDA} = 3.3\text{ V}$ , $T_A = 25\text{ }^{\circ}\text{C}$	-3	—	3	%
$I_{DDA(IRC40K)}^{(1)}$	IRC40K oscillator operating current	—	—	0.5	0.75	$\mu\text{A}$
$t_{ST(IRC40K)}^{(1)}$	IRC40K oscillator startup time	—	13	—	36	$\mu\text{s}$

(1) Value guaranteed by design, not 100% tested in production.

(2) Value guaranteed by characterization, not 100% tested in production.

## 4.12. PLL characteristics

The parameters given in Table 46 are derived from tests performed under temperature and  $V_{DD}$  supply voltage conditions summarized in [Table 4-3. General operating conditions](#).

**Table 4-24. PLL0 characteristics <sup>(1)</sup>**

Symbol	Description	Conditions	Min	Typ	Max	Unit
$f_{IN(PLL)}$	PLL input clock frequency	—	2	—	25	MHz
$f_{OUT(PLL)}$	PLL output clock frequency	$V_{DD} \geq 3.0\text{ V}$	32	—	280	MHz
		$V_{DD} \geq 2.6\text{ V}$	32	—	252	
$f_{VCO}$	PLL VCO output clock frequency	—	32	—	280	MHz
$t_{LK(PLL)}$	PLL lock time	—	—	—	1000	$\mu\text{s}$
$I_{DDA(PLL)}$	Current consumption from $V_{DDA}$	VCO freq = 280 MHz	—	808	—	$\mu\text{A}$
$J_{PLL}^{(2)}$	Cycle to cycle Jitter (rms)	System clock	—	15.9	—	ps
	Cycle to cycle Jitter (rms)		—	23.7	—	

(1) Value guaranteed by design, not 100% tested in production.

(2) System clock = IRC8M = 8 MHz, PLL0 clock source = HSE40/8 = 5 MHz,  $f_{PLL0OUT} = 280\text{ MHz}$ .

**Table 4-25. PLL1 characteristics <sup>(1)</sup>**

Symbol	Description	Conditions	Min	Typ	Max	Unit
$f_{IN(PLL)}$	PLL input clock frequency	—	2	—	25	MHz
$f_{OUT(PLL)}$	PLL output clock frequency	$V_{DD} \geq 3.0\text{ V}$	32	—	280	MHz
		$V_{DD} \geq 2.6\text{ V}$	32	—	252	
$f_{VCO}$	PLL VCO output clock frequency	—	32	—	280	MHz
$t_{LK(PLL)}$	PLL lock time	—	—	—	1000	$\mu\text{s}$
$I_{DDA(PLL)}$	Current consumption from $V_{DDA}$	VCO freq = 280 MHz	—	808	—	$\mu\text{A}$
$J_{PLL}^{(2)}$	Cycle to cycle Jitter (rms)	System clock	—	15.9	—	ps
	Cycle to cycle Jitter (rms)		—	23.7	—	

(1) Value guaranteed by design, not 100% tested in production.

(2) System clock = IRC8M = 8 MHz, PLL1 clock source = HSE40M/8 = 5 MHz,  $f_{PLLOUT}$  = 280 MHz.

## 4.13. Memory characteristics

**Table 4-26. Flash memory characteristics <sup>(1)</sup>**

Symbol	Description	Conditions	Min	Typ	Max	Unit
$PE_{CYC}$	Number of guaranteed program /erase cycles before failure (Endurance)	$T_A = -40\text{ }^\circ\text{C} \sim +85\text{ }^\circ\text{C}$	100	—	—	kcycles
$t_{RET}$	Data retention time	$T_A = 70\text{ }^\circ\text{C}$ after up to 0 kcycle	—	20	—	years
$t_{PROG}$	Word programming time	$T_A = -40\text{ }^\circ\text{C} \sim +85\text{ }^\circ\text{C}$	—	47.5	106	$\mu\text{s}$
$t_{PER}$	Page erase time		—	45	300	ms
$t_{MER(512K)}$	Mass erase time		—	4	25.6	s
$t_{MER(1MB)}$	Mass erase time		—	6	38.4	s

(1) Value guaranteed by design, not 100% tested in production.

### 4.14. NRST pin characteristics

Table 4-27. NRST pin characteristics <sup>(1)</sup>

Symbol	Description	Conditions	Min	Typ	Max	Unit
$V_{IL(NRST)}$	NRST Input low level voltage	—	-0.3	—	$0.3V_{DD}$	V
$V_{IH(NRST)}$	NRST Input high level voltage	—	$0.7V_{DD}$	—	$V_{DD}+0.3$	
$V_{HYST}$	Schmidt trigger Voltage hysteresis	$V_{DD} = V_{DDA} = 2.6\text{ V}$	—	340	—	mV
		$V_{DD} = V_{DDA} = 3.3\text{ V}$	—	430	—	
		$V_{DD} = V_{DDA} = 3.6\text{ V}$	—	480	—	
$R_{PU}$	Pull-up equivalent resistor	$V_{IN} = V_{SS}$	—	40	—	k $\Omega$
$t_{NRST\_F}$	Generated filtered reset pulse duration	—	—	—	100	ns
$t_{NRST\_NF}$	Generated not filtered reset pulse duration	—	350	—	—	

(1) Value guaranteed by design, not 100% tested in production.

Figure 4-9. Recommended external NRST pin circuit<sup>(1)</sup>

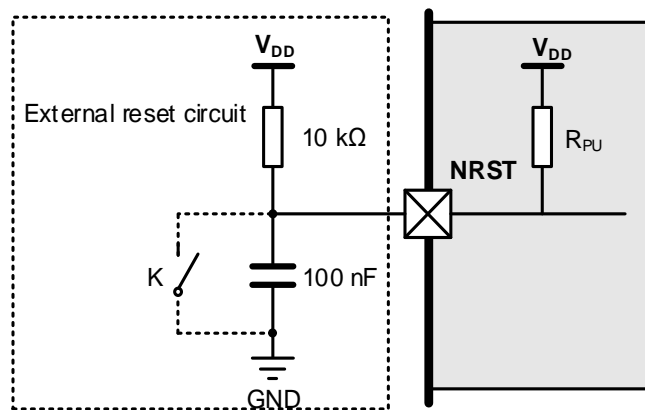

(1) Unless the voltage on NRST pin go below  $V_{IL(NRST)}$  level, the device would not generate a reliable reset.

## 4.15. GPIO current injection characteristics

As a general rule, current injection to the I/O pins, due to external voltage below VSS or above VDD (for standard, 3.3 V-capable I/O pins) should be avoided during normal product operation. However, in order to give an indication of the robustness of the microcontroller in cases when abnormal injection accidentally happens, susceptibility tests are performed on a sample basis during device characterization.

### Functional susceptibility to I/O current injection

While a simple application is executed on the device, the device is stressed by injecting current into the I/O pins programmed in floating input mode. While current is injected into the I/O pin, one at a time, the device is checked for functional failures. The failure is indicated by an out of range parameter: ADC error above a certain limit (higher than 5 LSB TUE), out of conventional limits of induced leakage current on adjacent pins (out of the  $-5 \mu\text{A}/+0 \mu\text{A}$  range) or other functional failure (for example reset occurrence or oscillator frequency deviation).

Negative induced leakage current is caused by negative injection and positive induced leakage current is caused by positive injection.

**Table 4-28. GPIO current injection susceptibility<sup>(1)</sup>**

Symbol	Description		Functional susceptibility		Unit
			Negative injection	Positive injection	
$I_{\text{INJ}}$	Injected current on pin	Input current on 5V tolerant pin	-5	NA	mA
		Input current on other I/O(Except BOOT0)	-5	0	
		BOOT0	0	NA	

(1) Value guaranteed by sample, not 100% tested in production.

## 4.16. GPIO characteristics

More details about GPIO could be found in [AN092 GD32 MCU GPIO structure and precautions](#).

**Table 4-29. I/O static characteristics**

Symbol	Description	Conditions	Min	Typ	Max	Unit
$V_{\text{IL}}^{(1)}$	Standard IO low level input voltage	$2.6 \text{ V} < V_{\text{DD}} = V_{\text{DDA}} < 3.6 \text{ V}$	—	—	$0.3V_{\text{DD}}$	V
	5V-tolerant IO low level input voltage	$2.6 \text{ V} < V_{\text{DD}} = V_{\text{DDA}} < 3.6 \text{ V}$	—	—	$0.3V_{\text{DD}}$	V
$V_{\text{IH}}^{(1)}$	Standard IO high level input voltage	$2.6 \text{ V} < V_{\text{DD}} = V_{\text{DDA}} < 3.6 \text{ V}$	$0.7V_{\text{DD}}$	—	—	V
	5V-tolerant IO high level input voltage	$2.6 \text{ V} < V_{\text{DD}} = V_{\text{DDA}} < 3.6 \text{ V}$	$0.7V_{\text{DD}}$	—	—	V

Symbol	Description		Conditions	Min	Typ	Max	Unit
$V_{HYS}^{(1)}$	Input hysteresis		—	—	320	—	mV
$I_{LEAK}$	IO input leakage current		$V_{SS} \leq V_{IN} \leq V_{DD}/V_{DDA}$	—	—	2	$\mu A$
$R_{PU}^{(1)}$	Weak pull-up equivalent resistor	All pins	$V_{IN} = V_{SS}$	—	40	—	k $\Omega$
		PA10	—	—	10	—	
$R_{PD}^{(1)}$	Weak pull-down equivalent resistor	All pins	$V_{IN} = V_{DD}$	—	40	—	k $\Omega$
		PA10	—	—	10	—	
$C_{IO}^{(1)}$	I/O pin capacitance		—	—	5	—	pF

(1) Value guaranteed by design, not 100% tested in production.

**Table 4-30. Output voltage characteristics for all I/Os except PC13, PC14, PC15 <sup>(1)(2)</sup>**

Symbol	Description	Conditions	Min	Typ <sup>(3)</sup>	Max	Unit
$V_{OL}$ (IO_speed=Level 3)	Low level output voltage for an IO Pin ( $I_{IO} = +8$ mA)	$V_{DD} = 2.6$ V	TBD	0.13	TBD	V
		$V_{DD} = 3.3$ V	TBD	0.12	TBD	
		$V_{DD} = 3.6$ V	TBD	0.11	TBD	
	Low level output voltage for an IO Pin ( $I_{IO} = +20$ mA)	$V_{DD} = 2.6$ V	TBD	0.33	TBD	
		$V_{DD} = 3.3$ V	TBD	0.29	TBD	
		$V_{DD} = 3.6$ V	TBD	0.29	TBD	
$V_{OH}$ (IO_speed= Level 3)	High level output voltage for an IO Pin ( $I_{IO} = +8$ mA)	$V_{DD} = 2.6$ V	TBD	2.47	TBD	V
		$V_{DD} = 3.3$ V	TBD	3.20	TBD	
		$V_{DD} = 3.6$ V	TBD	3.53	TBD	
	High level output voltage for an IO Pin ( $I_{IO} = +20$ mA)	$V_{DD} = 2.6$ V	TBD	2.27	TBD	
		$V_{DD} = 3.3$ V	TBD	3.02	TBD	
		$V_{DD} = 3.6$ V	TBD	3.36	TBD	
$V_{OL}$ (IO_speed= Level 2)	Low level output voltage for an IO Pin ( $I_{IO} = +8$ mA)	$V_{DD} = 2.6$ V	TBD	0.16	TBD	V
		$V_{DD} = 3.3$ V	TBD	0.15	TBD	
		$V_{DD} = 3.6$ V	TBD	0.14	TBD	
	Low level output voltage for an IO Pin ( $I_{IO} = +20$ mA)	$V_{DD} = 2.6$ V	TBD	0.44	TBD	
		$V_{DD} = 3.3$ V	TBD	0.38	TBD	
		$V_{DD} = 3.6$ V	TBD	0.37	TBD	
$V_{OH}$ (IO_speed= Level 2)	High level output voltage for an IO Pin ( $I_{IO} = +8$ mA)	$V_{DD} = 2.6$ V	TBD	2.43	TBD	V
		$V_{DD} = 3.3$ V	TBD	3.16	TBD	
		$V_{DD} = 3.6$ V	TBD	3.49	TBD	
	High level output voltage for an IO Pin ( $I_{IO} = +20$ mA)	$V_{DD} = 2.6$ V	TBD	2.13	TBD	
		$V_{DD} = 3.3$ V	TBD	2.92	TBD	
		$V_{DD} = 3.6$ V	TBD	3.26	TBD	
$V_{OL}$ (IO_speed= Level 1)	Low level output voltage for an IO Pin ( $I_{IO} = +8$ mA)	$V_{DD} = 2.6$ V	TBD	0.33	TBD	V
		$V_{DD} = 3.3$ V	TBD	0.30	TBD	
		$V_{DD} = 3.6$ V	TBD	0.28	TBD	
	Low level output voltage for an IO Pin ( $I_{IO} = +15$ mA)	$V_{DD} = 2.6$ V	TBD	0.68	TBD	
		$V_{DD} = 3.3$ V	TBD	0.57	TBD	
		$V_{DD} = 3.6$ V	TBD	0.54	TBD	
$V_{OH}$ (IO_speed= Level 1)	High level output voltage for an IO Pin	$V_{DD} = 2.6$ V	TBD	2.30	TBD	V
		$V_{DD} = 3.3$ V	TBD	3.05	TBD	

Symbol	Description	Conditions	Min	Typ <sup>(3)</sup>	Max	Unit
	(I <sub>IO</sub> = +8 mA)	V <sub>DD</sub> = 3.6 V	TBD	3.39	TBD	V
	High level output voltage for an IO Pin (I <sub>IO</sub> = +15 mA)	V <sub>DD</sub> = 2.6 V	TBD	1.97	TBD	
		V <sub>DD</sub> = 3.3 V	TBD	2.80	TBD	
		V <sub>DD</sub> = 3.6 V	TBD	3.16	TBD	
V <sub>OL</sub> (IO_speed= Level 0)	Low level output voltage for an IO Pin (I <sub>IO</sub> = +1 mA)	V <sub>DD</sub> = 2.6 V	TBD	0.11	TBD	
		V <sub>DD</sub> = 3.3 V	TBD	0.10	TBD	
		V <sub>DD</sub> = 3.6 V	TBD	0.10	TBD	
	Low level output voltage for an IO Pin (I <sub>IO</sub> = +4 mA)	V <sub>DD</sub> = 2.6 V	TBD	0.50	TBD	
		V <sub>DD</sub> = 3.3 V	TBD	0.42	TBD	
		V <sub>DD</sub> = 3.6 V	TBD	0.41	TBD	
V <sub>OH</sub> (IO_speed= Level 0)	High level output voltage for an IO Pin (I <sub>IO</sub> = +1 mA)	V <sub>DD</sub> = 2.6 V	TBD	2.42	TBD	
		V <sub>DD</sub> = 3.3 V	TBD	3.15	TBD	
		V <sub>DD</sub> = 3.6 V	TBD	3.49	TBD	
	High level output voltage for an IO Pin (I <sub>IO</sub> = +4 mA)	V <sub>DD</sub> = 2.6 V	TBD	1.71	TBD	
		V <sub>DD</sub> = 3.3 V	TBD	2.64	TBD	
		V <sub>DD</sub> = 3.6 V	TBD	3.02	TBD	

(1) Value guaranteed by characterization, not 100% tested in production.

(2) All pins except PC13 / PC14 / PC15. Since PC13 to PC15 are supplied through the Power Switch, which can only be obtained by a small current (typical source capability:3 mA shared between these IOs, but sink capability is same as other IO), the speed of GPIOs PC13 to PC15 should not exceed 2 MHz when they are in output mode (maximum load: 30 pF).

(3) Value guaranteed by sample, not 100% tested in production.

**Table 4-31. I/O port AC characteristics** <sup>(1)(2)(3)</sup>

Speed	Symbol	Description	Conditions	Min	Typ	Max	Unit
00	t <sub>R</sub> /t <sub>F</sub>	Output high to low level fall time and output low to high level rise time	2.6 ≤ V <sub>DD</sub> ≤ 3.6 V, C <sub>L</sub> = 10 pF	—	—	9.5	ns
			2.6 ≤ V <sub>DD</sub> ≤ 3.6 V, C <sub>L</sub> = 30 pF	—	—	25	
			2.6 ≤ V <sub>DD</sub> ≤ 3.6 V, C <sub>L</sub> = 50 pF	—	—	40	
01	t <sub>R</sub> /t <sub>F</sub>	Output high to low level fall time and output low to high level rise time	2.6 ≤ V <sub>DD</sub> ≤ 3.6 V, C <sub>L</sub> = 10 pF	—	—	2.7	ns
			2.6 ≤ V <sub>DD</sub> ≤ 3.6 V, C <sub>L</sub> = 30 pF	—	—	7	
			2.6 ≤ V <sub>DD</sub> ≤ 3.6 V, C <sub>L</sub> = 50 pF	—	—	11	
10	t <sub>R</sub> /t <sub>F</sub>	Output high to low level fall time and output low to high level rise time	2.6 ≤ V <sub>DD</sub> ≤ 3.6 V, C <sub>L</sub> = 10 pF	—	—	2	ns
			2.6 ≤ V <sub>DD</sub> ≤ 3.6 V, C <sub>L</sub> = 30 pF	—	—	3.5	
			2.6 ≤ V <sub>DD</sub> ≤ 3.6 V, C <sub>L</sub> = 50 pF	—	—	5.5	
11	t <sub>R</sub> /t <sub>F</sub>	Output high to low level fall time and output low to high level rise time	2.6 ≤ V <sub>DD</sub> ≤ 3.6 V, C <sub>L</sub> = 10 pF	—	—	1.3	ns
			2.6 ≤ V <sub>DD</sub> ≤ 3.6 V, C <sub>L</sub> = 30 pF	—	—	2.6	
			2.6 ≤ V <sub>DD</sub> ≤ 3.6 V, C <sub>L</sub> = 50 pF	—	—	4	

(1) The fall and rise times are defined between 90% and 10% and between 10% and 90% of the output waveform, respectively.

(2) Value guaranteed by design, not 100% tested in production.

(3) The data is for reference only, and the specific values are related to PCB Layout.

## 4.17. Internal reference voltage characteristics

**Table 4-32. Internal reference voltage characteristics<sup>(1)</sup>**

Symbol	Description	Conditions	Min	Typ	Max	Unit
V <sub>REFINT</sub>	Internal reference voltage	T <sub>A</sub> = -40°C ~ +85°C	1.172	—	1.242	V
t <sub>S_VREFINT</sub> <sup>(2)</sup>	ADC sampling time when reading the internal reference voltage	—	17.1	—	—	μs
t <sub>STA_VREFINT</sub>	Start time of reference voltage buffer when ADC is enable	—	—	3	—	μs
I <sub>DD(VREFINT_BUFFER)</sub>	V <sub>REFINT</sub> buffer consumption from V <sub>DD</sub> when converted by ADC	—	—	4.5	—	μA
ΔV <sub>REFINT</sub>	Internal reference voltage spread over the temperature range	—	—	—	70	mV
T <sub>Coeff</sub>	Temperature coefficient	—	—	—	39	ppm/°C

(1) Value guaranteed by design, not 100% tested in production.

(2) The shortest sampling time can be determined in the application by multiple iterations.

**Table 4-33. Internal reference voltage calibration values**

Symbol	Test conditions	Memory address
V <sub>REFINT</sub> <sup>(1)</sup>	V <sub>DD</sub> = V <sub>DDA</sub> = V <sub>REFP</sub> = 3.3 V (± 10 mV), Temperature = 25 °C (± 5 °C)	0x1FFFF7FC-0x1FFFF7FD

(1) V<sub>REFINT</sub> is internally connected to the ADC0\_IN17 input channel.

## 4.18. ADC characteristics

**Table 4-34. ADC operating conditions<sup>(1)</sup>**

Symbol	Description	Conditions	Min	Typ	Max	Unit
V <sub>DDA</sub>	Operating voltage	—	2.6	3.3	3.6	V
V <sub>IN</sub>	ADC input voltage range	—	0	—	V <sub>REFP</sub>	V
V <sub>REFP</sub> <sup>(2)</sup>	Positive Reference Voltage	—	2.6	—	V <sub>DDA</sub>	V
V <sub>REFN</sub>	Negative Reference Voltage	—	—	V <sub>SSA</sub>	—	V
f <sub>ADC</sub>	ADC clock	—	0.1	—	42	MHz

(1) Value guaranteed by design, not 100% tested in production.

(2) V<sub>REFP</sub> should always be equal to or less than V<sub>DDA</sub>, especially during power up.

**Table 4-35. ADC characteristics<sup>(1)</sup>**

Symbol	Description	Conditions	Min	Typ	Max	Unit
R <sub>AIN</sub>	External input impedance	See <a href="#">Equation 1</a>	—	—	74.16	kΩ
R <sub>ADC</sub>	Input sampling switch	—	—	—	0.5	kΩ

Symbol	Description	Conditions	Min	Typ	Max	Unit
	resistance					
C <sub>ADC</sub>	Input sampling capacitance	No pin/pad capacitance included	—	—	2.87	pF
t <sub>s</sub>	Sampling time	f <sub>ADC</sub> = 42 MHz	0.0357	—	5.7	μs
t <sub>CONV</sub>	Total conversion time(including sampling time)	12-bit	—	14	—	1/ f <sub>ADC</sub>
		10-bit	—	12	—	
		8-bit	—	10	—	
		6-bit	—	8	—	
f <sub>s</sub>	Sampling rate	12-bit	0.007	—	3	MSP S
		10-bit	0.008	—	3.5	
		8-bit	0.01	—	4.2	
		6-bit	0.012	—	5.25	
t <sub>ST(ADC)</sub>	Startup time	—	—	—	1	μs
I <sub>DDA(ADC)</sub>	ADC consumption on V <sub>DDA</sub> and V <sub>REF</sub>	—	—	850	—	μA

(1) Value guaranteed by design, not 100% tested in production.

$$\text{Equation 1: } R_{AIN \max} \text{ formula } R_{AIN} < \frac{T_s}{f_{ADC} * C_{ADC} * \ln(2^{N+2})} - R_{ADC}$$

According to the equation, we can determine the maximum external impedance. Here N = 12 when ADC work in 12-bit resolution.

**Table 4-36. ADC R<sub>AIN max</sub> for f<sub>ADC</sub> = 42 MHz<sup>(1)</sup>**

T <sub>s</sub> (cycles)	t <sub>s</sub> (μs)	R <sub>AIN max</sub> (kΩ) <sup>(2)</sup>
1.5	0.0357	—
7.5	0.1786	1.83
13.5	0.3214	3.70
28.5	0.6786	8.38
41.5	0.9881	12.43
55.5	1.3214	16.80
71.5	1.7024	21.79
239.5	5.7024	74.16

(1) Value guaranteed by design, not 100% tested in production.

(2) Extra external capacitors (such as pin capacitors, etc.) need to be considered when calculating the actual R<sub>AIN</sub>. Here we take 5 pF for the extra internal capacitance, C<sub>ADC</sub> = 2.87 pF + 5pF = 7.87 pF.

**Table 4-37. ADC performance characteristics<sup>(1)(2)(3)(4)</sup>**

Symbol	Description	Test conditions	Min	Typ	Max	Unit
ENOB	Effective number of bits	f <sub>ADC</sub> = 42 MHz <sup>(2)</sup>	—	10.98	—	bits
SNDR	Signal-to-noise and distortion ratio	f <sub>ADC</sub> = 42 MHz <sup>(2)</sup>	—	67.85	—	dB
SNR	Signal-to-noise ratio	f <sub>ADC</sub> = 42 MHz <sup>(2)</sup>	—	68.02	—	
THD	Total harmonic distortion	f <sub>ADC</sub> = 42 MHz <sup>(2)</sup>	—	-81.48	—	
EO	Offset error	f <sub>ADC</sub> = 42 MHz V <sub>DDA</sub> = V <sub>REFP</sub> = 3.3 V	—	±1	—	LSB
DNL	Differential linearity error		—	±1	—	
INL	Integral linearity error		—	±1.2	—	

- (1) Value guaranteed by sample, not 100% tested in production.
- (2)  $V_{DDA} = V_{REFP} = 3.3\text{ V}$ , Input Frequency = 20 kHz, Temperature = 25 °C
- (3) Some guidance is provided to improve the sampling accuracy of ADC. Refer to [AN059 Methods to improve ADC sampling accuracy](#).
- (4) The data comes from LQFP 100 package, ADC0.

**Figure 4-10. Differential linearity error**

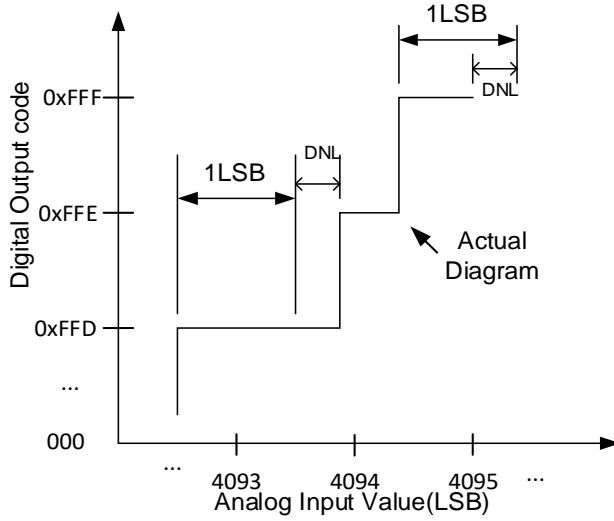

**Figure 4-11. Integral linearity error**

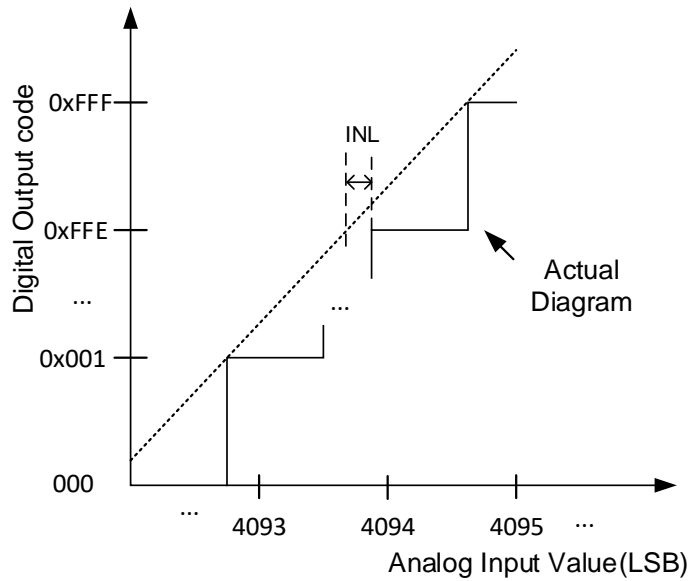

## 4.19. Temperature sensor characteristics

**Table 4-38. Temperature sensor characteristics<sup>(1)</sup>**

Symbol	Description	Min	Typ	Max	Unit
$T_{LIN}$	Linearity of temperature sensitive voltage	—	$\pm 2$	—	$^{\circ}\text{C}$
Avg_Slope	Average slope	—	4.35	—	mV/ $^{\circ}\text{C}$
$V_{30}$	Voltage at 30 $^{\circ}\text{C}$	—	1.524	—	V
$t_{ST(TS)}$	Start up time	—	10	—	$\mu\text{s}$
$t_{S\_temp}^{(2)}$	ADC sampling time when reading the temperature	—	17.1	—	$\mu\text{s}$

(1) Value guaranteed by design, not 100% tested in production.

(2) Shortest sampling time can be determined in the application by multiple iterations.

**Table 4-39. Temperature sensor calibration values**

Symbol	Description	Memory address
TS_CAL	Temperature sensor raw data acquired value at 30 $^{\circ}\text{C}$ ( $\pm 3$ $^{\circ}\text{C}$ ), $V_{DD} = V_{DDA} = V_{REFP} = 3.3\text{V}$ ( $\pm 5$ mV)	0x1FFFF7F8 - 0x1FFFF7F9

## 4.20. DAC characteristics

**Table 4-40. DAC characteristics<sup>(1)</sup>**

Symbol	Parameter	Conditions	Min	Typ	Max	Unit	
$V_{DDA}$	Operating voltage	—	2.6	3.3	3.6	V	
$V_{REFP}$	Positive Reference Voltage	—	2.6	—	$V_{DDA}$	V	
$V_{REFN}$	Negative Reference Voltage	—	—	$V_{SSA}$	—	V	
$I_{DDA}$	DAC current consumption in quiescent mode	DAC output buffer ON	No load, middle code (0x800), $V_{REFP} = 3.6\text{V}$	—	400	—	$\mu\text{A}$
		DAC output buffer ON	No load, worst code (0xF1C), $V_{REFP} = 3.6\text{V}$	—	420	—	
		DAC output buffer OFF	No load, middle (0x800), $V_{REFP} = 3.6\text{V}$	—	5	—	
$I_{DDVREFP}$	DAC current consumption in quiescent mode	DAC output buffer ON	No load, middle code (0x800), $V_{REFP} = 3.6\text{V}$	—	100	—	$\mu\text{A}$
		DAC output buffer ON	No load, worst code (0xF1C), $V_{REFP} = 3.6\text{V}$	—	360	—	

Symbol	Parameter	Conditions	Min	Typ	Max	Unit	
		DAC output buffer OFF	No load, middle code (0x800), $V_{REFP} = 3.6\text{ V}$	—	5	—	

(1) Value guaranteed by design, not 100% tested in production.

**Table 4-41. DAC characteristics<sup>(1)</sup>**

Symbol	Description	Conditions	Min	Typ <sup>(1)</sup>	Max	Unit
$R_{LOAD}$	Load resistance	Resistive load connected to $V_{SSA}$	5	—	—	k $\Omega$
		with buffer ON connected to $V_{DDA}$	5	—	—	
$R_o$	Impedance output with buffer OFF	Impedance output with buffer OFF	—	—	15	k $\Omega$
$C_{LOAD}$	Load capacitance	No pin/pad capacitance included	—	—	50	pF
DAC_OUT	Voltage on DAC_OUT output	buffer OFF	1LSB	—	$V_{DDA}$ -1LSB	V
		buffer ON	0.2	—	$V_{DDA}$ -0.2	V

(1) Value guaranteed by design, not 100% tested in production.

**Table 4-42. DAC performance characteristics**

Symbol	Description	Conditions	Min	Typ	Max	Unit	
DNL <sup>(1)</sup>	Differential non-linearity	DAC output buffer ON	—	$\pm 1$	—	LSB	
		DAC output buffer OFF	—	$\pm 1$	—		
INL <sup>(1)</sup>	Integral non-linearity	DAC output buffer ON	—	$\pm 1.5$	—	LSB	
		DAC output buffer OFF	—	$\pm 1.5$	—		
Offset <sup>(1)</sup>	Offset error	DAC output buffer ON	—	$\pm 2$	—	LSB	
		DAC output buffer OFF	—	$\pm 2$	—		
GE <sup>(1)</sup>	Gain error	DAC output buffer ON	—	$\pm 0.1$	—	%	
		DAC output buffer OFF	—	$\pm 0.1$	—		
$t_{SETTLING}^{(2)}$	Settling time (full scale: for a 12-bit code transition between the lowest and the highest input codes when DAC_OUT reaches the final value of $\pm 1\text{LSB}$ , $\pm 2\text{LSB}$ , $\pm 4\text{LSB}$ , $\pm 8\text{LSB}$ )	Normal mode, DAC output buffer ON, CL $\leq 50\text{ pF}$ , RL $\geq 5\text{ k}\Omega$	$\pm 1\text{ LSB}$	—	0.6	—	$\mu\text{s}$
			$\pm 2\text{ LSB}$	—	0.52	—	
			$\pm 4\text{ LSB}$	—	0.51	—	
			$\pm 8\text{ LSB}$	—	0.5	—	
		Normal mode, DAC output buffer OFF, $\pm 1\text{LSB}$ CL=10 pF	—	2	—		
$t_{WAKEUP}^{(2)}$	Wakeup time from off state (setting the ENx bit in the DAC Control register) until the final value of $\pm 1\text{LSB}$ is reached	Normal mode, DAC output buffer ON, CL $\leq 50\text{ pF}$ , RL = 5 k $\Omega$	—	5	10	$\mu\text{s}$	
		Normal mode, DAC output buffer OFF, CL $\leq 10\text{ pF}$	—	3	6		
Update rate <sup>(2)</sup>	Max frequency for a correct DAC_OUT change from code i to $i \pm 1\text{LSBs}$	$C_{LOAD} \leq 50\text{ pF}$ , $R_{LOAD} \geq 5\text{ k}\Omega$	—	—	4	MS/s	

Symbol	Description	Conditions	Min	Typ	Max	Unit
PSRR <sup>(2)</sup>	Power supply rejection ratio(to $V_{DDA}$ )	No $R_{LOAD}$ , $C_{LOAD}=50$ pF	70	90	—	dB

- (1) Value guaranteed by sample, not 100% tested in production.  
 (2) Value guaranteed by design, not 100% tested in production.

Figure 4-12. 12-bit buffered /non-buffered DAC

Buffered/Non-buffered DAC

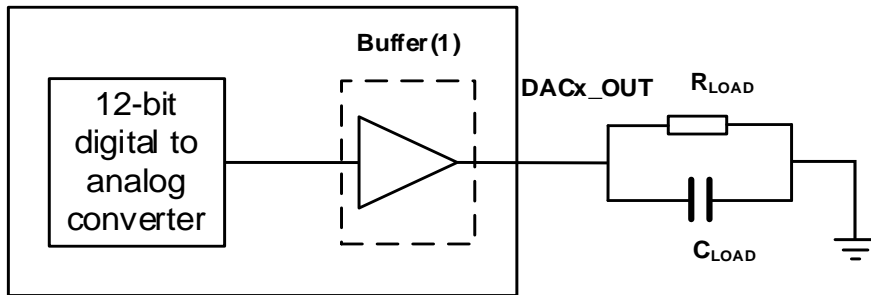

- (1) The DAC integrates an output buffer to reduce the output impedance and to drive external loads directly without the use of an external operational amplifier. The buffer can be bypassed by configuring the DBOFFx bit in the DAC\_CTL0 register.

## 4.21. I2C characteristics

Table 4-43. I2C characteristics<sup>(1)(2)</sup>

Symbol	Description	Conditions	Standard mode		Fast mode		Fast mode plus		Unit
			Min	Max	Min	Max	Min	Max	
$t_{SCL(H)}$	SCL clock high time	—	4.0	—	0.6	—	0.2	—	$\mu$ s
$t_{SCL(L)}$	SCL clock low time	—	4.7	—	1.3	—	0.5	—	$\mu$ s
$t_{SU(SDA)}$	SDA setup time	—	250	—	100	—	50	—	ns
$t_{H(SDA)}$	SDA data hold time	—	0 <sup>(3)</sup>	3450	0 <sup>(3)</sup>	900	0	450	ns
$t_{R(SDA/SCL)}$	SDA and SCL rise time	—	—	1000	—	300	—	120	ns
$t_{F(SDA/SCL)}$	SDA and SCL fall time	—	—	300	—	300	—	120	ns
$t_{H(STA)}$	Start condition hold time	—	4.0	—	0.6	—	0.26	—	$\mu$ s
$t_{SU(STA)}$	Repeated Start condition setup time	—	4.7	—	0.6	—	0.26	—	$\mu$ s
$t_{SU(STO)}$	Stop condition setup time	—	4.0	—	0.6	—	0.26	—	$\mu$ s

Symbol	Description	Conditions	Standard mode		Fast mode		Fast mode plus		Unit
			Min	Max	Min	Max	Min	Max	
t <sub>BUFF</sub>	Stop to Start condition time (bus free)	—	4.7	—	1.3	—	0.5	—	μs

- (1) Value guaranteed by design, not 100% tested in production.
- (2) To ensure the standard mode I2C frequency, f<sub>PCLK1</sub> must be at least 2 MHz. To ensure the fast mode I2C frequency, f<sub>PCLK1</sub> must be at least 4 MHz. To ensure the fast mode plus I2C frequency, f<sub>PCLK1</sub> must be at least a multiple of 10 MHz.
- (3) The device should provide a data hold time of 300 ns at least in order to bridge the undefined region of the falling edge of SCL.

Figure 4-13. I2C bus timing diagram

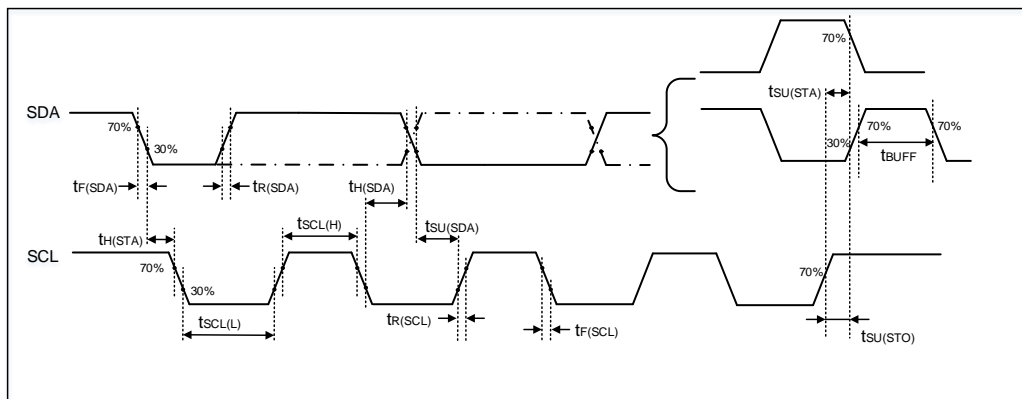

## 4.22. SPI characteristics

Table 4-44. Standard SPI characteristics<sup>(1)</sup>

Symbol	Description	Conditions	Min	Typ	Max	Unit
f <sub>SCK</sub>	SCK clock frequency	—	—	—	40	MHz
t <sub>SCK(H)</sub>	SCK clock high time	Master mode, f <sub>PCLKx</sub> = 80 MHz, presc = 2	—	12.5	—	ns
t <sub>SCK(L)</sub>	SCK clock low time	Master mode, f <sub>PCLKx</sub> = 80 MHz, presc = 2	—	12.5	—	ns
<b>SPI master mode</b>						
t <sub>V(MO)</sub>	Data output valid time	—	—	—	5.5	ns
t <sub>SU(MI)</sub>	Data input setup time	—	1	—	—	ns
t <sub>H(MI)</sub>	Data input hold time	—	2	—	—	ns
<b>SPI slave mode</b>						
t <sub>SU(NSS)</sub>	NSS enable setup time	—	0	—	—	ns
t <sub>H(NSS)</sub>	NSS enable hold time	—	1	—	—	ns
t <sub>A(SO)</sub>	Data output access time	—	5	—	9	ns
t <sub>DIS(SO)</sub>	Data output disable time	—	6	—	10	ns
t <sub>V(SO)</sub>	Data output valid time	—	—	—	12	ns

Symbol	Description	Conditions	Min	Typ	Max	Unit
$t_{SU(SI)}$	Data input setup time	—	0	—	—	ns
$t_{H(SI)}$	Data input hold time	—	1	—	—	ns

(1) Value guaranteed by design, not 100% tested in production.

Figure 4-14. SPI timing diagram - master mode

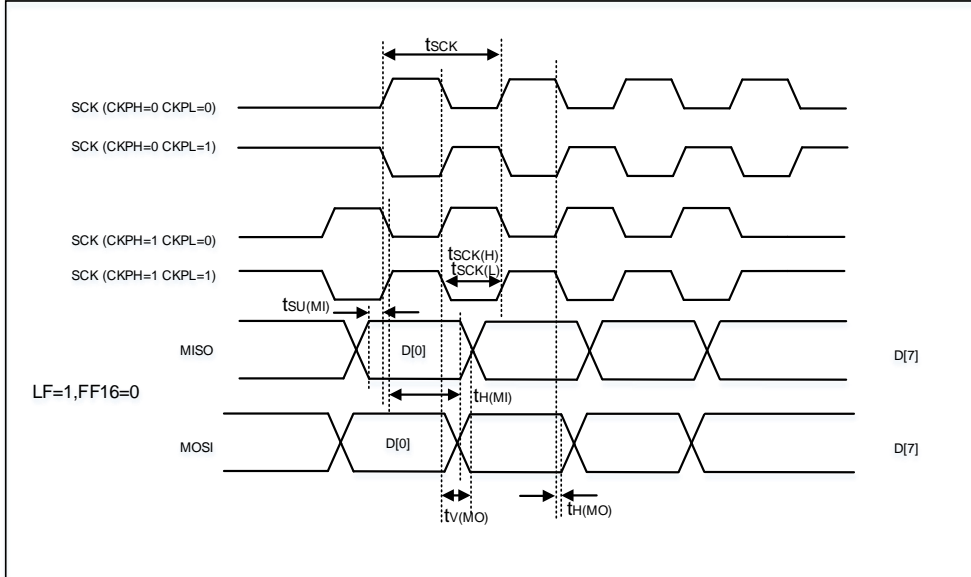

Figure 4-15. SPI timing diagram - slave mode(CKPH=0)

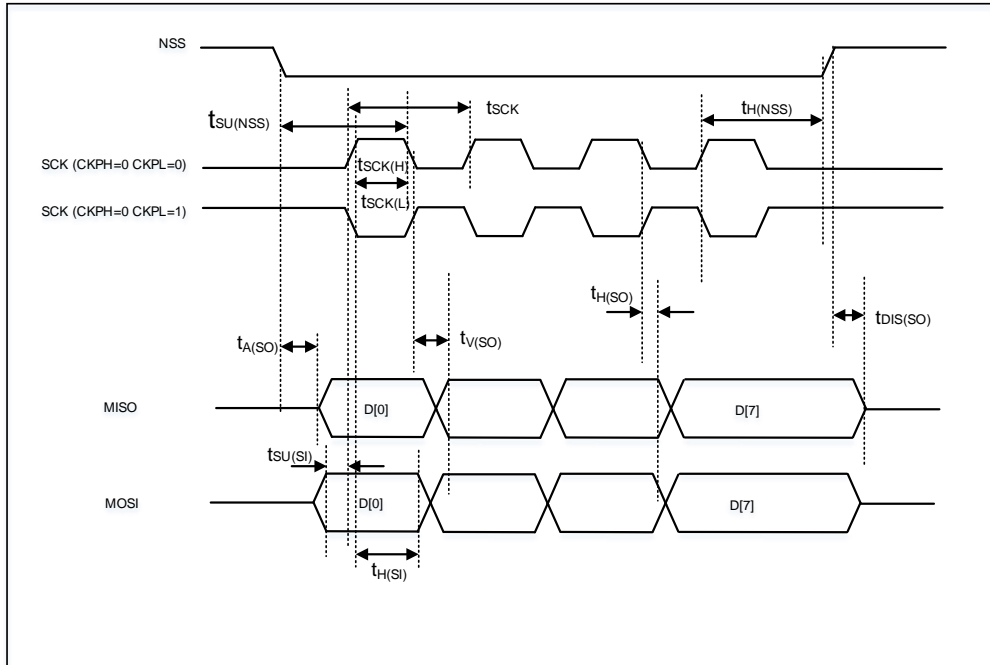
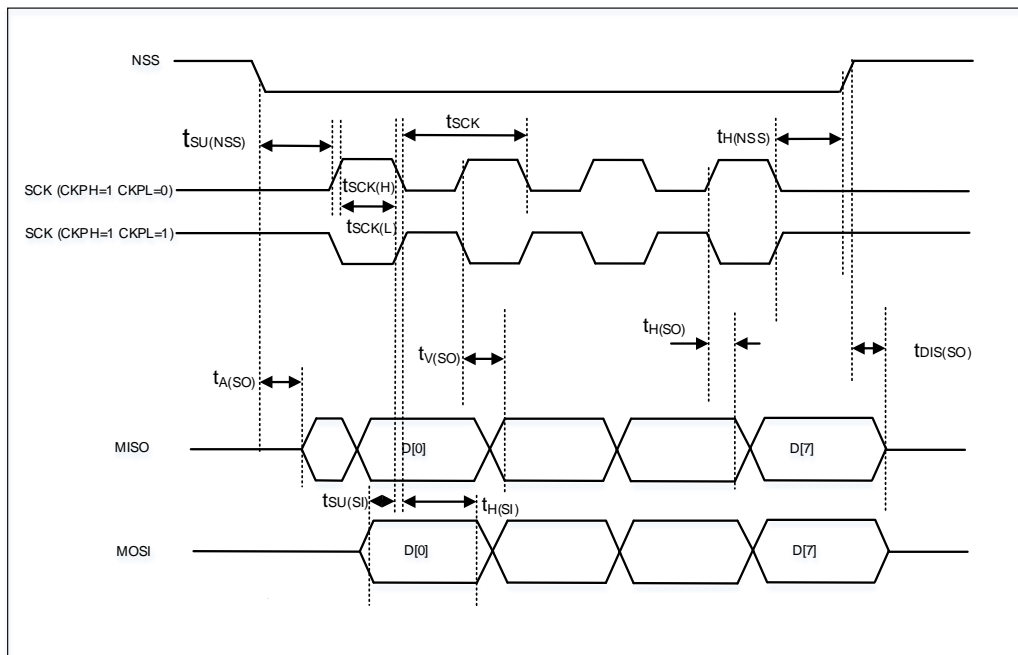

Figure 4-16. SPI timing diagram - slave mode(CKPH=1)



## 4.23. I2S characteristics

**Table 4-45. I2S characteristics<sup>(1)</sup>**

Symbol	Description	Conditions	Min	Typ	Max	Unit
f <sub>CK</sub>	Clock frequency	Master mode (data: 16 bits, Audio frequency = 96 kHz)	—	3	—	MHz
		Slave mode	—	—	10	
t <sub>H</sub>	Clock high time	—	—	166	—	ns
t <sub>L</sub>	Clock low time		—	166	—	ns
t <sub>V(WS)</sub>	WS valid time	Master mode	0	—	—	ns
t <sub>H(WS)</sub>	WS hold time	Master mode	0	—	—	ns
t <sub>SU(WS)</sub>	WS setup time	Slave mode	0	—	—	ns
t <sub>H(WS)</sub>	WS hold time	Slave mode	2	—	—	ns
Duty <sub>SCK</sub>	I2S slave input clock duty cycle	Slave mode	—	50	—	%
t <sub>SU(SD_MR)</sub>	Data input setup time	Master mode	2	—	—	ns
t <sub>SU(SD_SR)</sub>	Data input setup time	Slave mode	0	—	—	ns
t <sub>H(SD_MR)</sub>	Data input hold time	Master receiver	0	—	—	ns
t <sub>H(SD_SR)</sub>		Slave receiver	1	—	—	ns
t <sub>V(SD_ST)</sub>	Data output valid time	Slave transmitter (after enable edge)	—	—	12	ns
t <sub>H(SD_ST)</sub>	Data output hold time	Slave transmitter (after enable edge)	7	—	—	ns
t <sub>V(SD_MT)</sub>	Data output valid time	Master transmitter (after enable edge)	—	—	7	ns
t <sub>H(SD_MT)</sub>	Data output hold time	Master transmitter (after enable edge)	4	—	—	ns

(1) Value guaranteed by design, not 100% tested in production.

Figure 4-17. I2S timing diagram - master mode

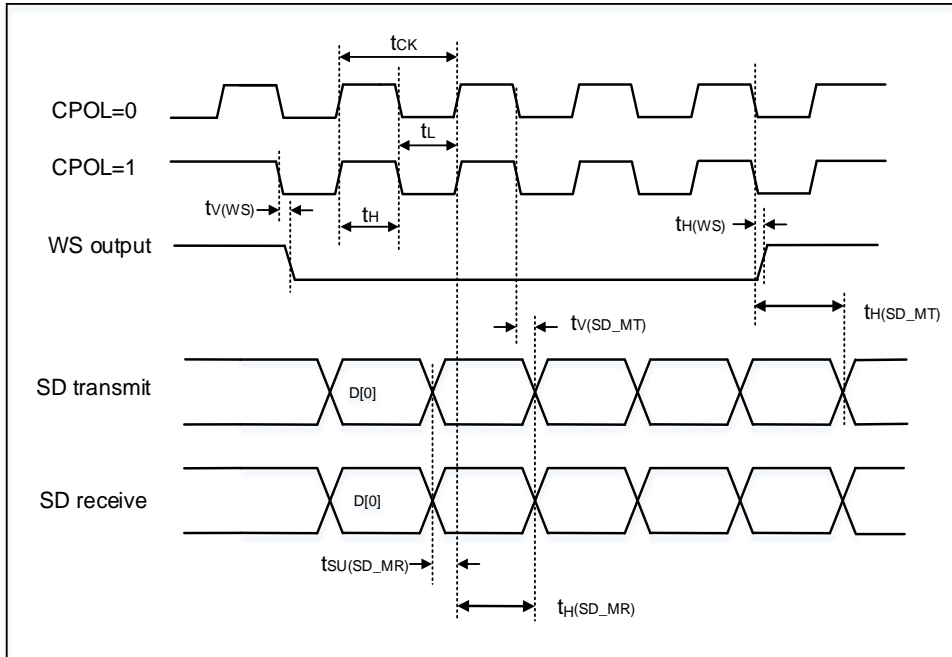
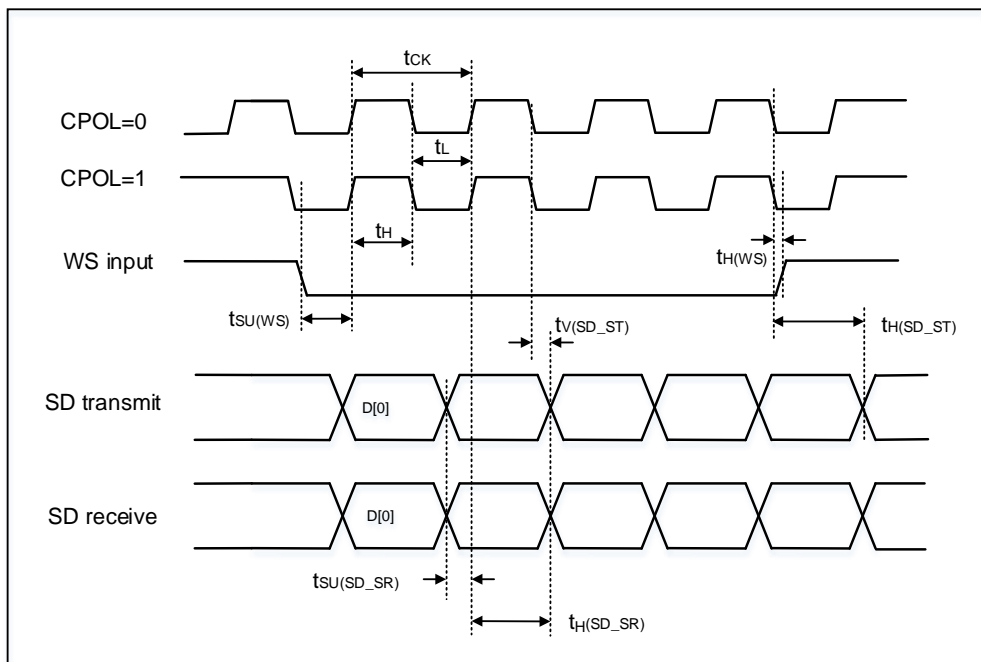

Figure 4-18. I2S timing diagram - slave mode



## 4.24. USART characteristics

**Table 4-46. USART0 characteristics in Synchronous mode<sup>(1)</sup>**

Symbol	Description	Conditions	Min	Typ	Max	Unit
f <sub>SCK</sub>	SCK clock frequency	f <sub>PCLK2</sub> = 200 MHz	—	—	25	MHz
t <sub>SCK(H)</sub>	SCK clock high time		20	—	—	ns
t <sub>SCK(L)</sub>	SCK clock low time		20	—	—	ns

(1) Value guaranteed by design, not 100% tested in production.

**Table 4-47. USART1/2 characteristics in Synchronous mode<sup>(1)</sup>**

Symbol	Description	Conditions	Min	Typ	Max	Unit
f <sub>SCK</sub>	SCK clock frequency	f <sub>PCLK1</sub> = 100 MHz	—	—	12.5	MHz
t <sub>SCK(H)</sub>	SCK clock high time		40	—	—	ns
t <sub>SCK(L)</sub>	SCK clock low time		40	—	—	ns

(1) Value guaranteed by design, not 100% tested in production.

**Table 4-48. USART0 characteristics in Smartcard mode<sup>(1)</sup>**

Symbol	Description	Conditions	Min	Typ	Max	Unit
f <sub>SCK</sub>	SCK clock frequency	f <sub>PCLK2</sub> = 200 MHz	—	—	100	MHz
t <sub>SCK(H)</sub>	SCK clock high time		5	—	—	ns
t <sub>SCK(L)</sub>	SCK clock low time		5	—	—	ns

(1) Value guaranteed by design, not 100% tested in production.

**Table 4-49. USART1/2 characteristics in Smartcard mode<sup>(1)</sup>**

Symbol	Description	Conditions	Min	Typ	Max	Unit
f <sub>SCK</sub>	SCK clock frequency	f <sub>PCLK1</sub> = 100 MHz	—	—	50	MHz
t <sub>SCK(H)</sub>	SCK clock high time		10	—	—	ns
t <sub>SCK(L)</sub>	SCK clock low time		10	—	—	ns

(1) Value guaranteed by design, not 100% tested in production.

**Table 4-50. USART3/4 characteristics<sup>(1)</sup>**

Symbol	Description	Conditions	Min	Typ	Max	Unit
f <sub>SCK</sub>	SCK clock frequency	f <sub>PCLK1</sub> = 100 MHz	—	—	50	MHz
t <sub>SCK(H)</sub>	SCK clock high time		10	—	—	ns
t <sub>SCK(L)</sub>	SCK clock low time		10	—	—	ns

(1) Value guaranteed by design, not 100% tested in production.

## 4.25. CAN characteristics

Refer to [Table 4-29. I/O static characteristics](#) for more details on the input/output alternate function characteristics (CAN TX and CAN RX).

## 4.26. TIMER characteristics

**Table 4-51. TIMER characteristics<sup>(1)</sup>**

Symbol	Parameter	Conditions	Min	Max	Unit
t <sub>res</sub>	Timer resolution time	—	1	—	t <sub>TIMERxCLK</sub>
		f <sub>TIMERxCLK</sub> = 200 MHz	5	—	ns
f <sub>EXT</sub>	Timer external clock frequency	—	0	f <sub>TIMERxCLK</sub> /2	MHz
		f <sub>TIMERxCLK</sub> = 200 MHz	0	100	MHz
RES	Timer resolution	TIMER0 & TIMER2 & TIMER3 & TIMER4 & TIMER5 & TIMER6 & TIMER7 & TIMER15 & TIMER16	—	16	bit
		TIMER1	—	32	bit
t <sub>COUNTER</sub>	16-bit counter clock period when internal clock is selected	—	1	65536	t <sub>TIMERxCLK</sub>
		f <sub>TIMERxCLK</sub> = 200 MHz	0.005	327.68	μs
	32-bit counter clock period when internal clock is selected	—	1	4294967296	t <sub>TIMERxCLK</sub>
		f <sub>TIMERxCLK</sub> = 200 MHz	0.005	21474836.48	μs
t <sub>MAX_COUNT</sub>	Maximum possible count (16-bit)	—	—	4294967296	t <sub>TIMERxCLK</sub>
		f <sub>TIMERxCLK</sub> = 200 MHz	—	21.47483648	s
	Maximum possible count (32-bit)	—	—	2.81475E+14	t <sub>TIMERxCLK</sub>
		f <sub>TIMERxCLK</sub> = 200 MHz	—	390.9374677	h

(1) Value guaranteed by design, not 100% tested in production.

## 4.27. USBFS characteristics

**Table 4-52. USBFS start up time<sup>(1)</sup>**

Symbol	Parameter	Max	Unit
t <sub>STARTUP</sub>	USBFS startup time	1	μs

(1) Value guaranteed by design, not 100% tested in production.

**Table 4-53. USBFS DC electrical characteristics<sup>(1)</sup>**

Symbol	Parameter	Conditions	Min	Typ	Max	Unit	
Input levels	V <sub>DD</sub>	USBFS operating voltage	—	3.0	—	3.6	V
	V <sub>DI</sub>	Differential input sensitivity	—	0.2	—	—	
	V <sub>CM</sub>	Differential common mode range	Includes V <sub>DI</sub> range	0.8	—	2.5	
	V <sub>SE</sub>	Single ended receiver threshold	—	0.8	—	2.0	
Output levels	V <sub>OL</sub>	Static output level low	R <sub>L</sub> of 1.5 kΩ to V <sub>DD</sub>	—	—	0.2	V
	V <sub>OH</sub>	Static output level high	R <sub>L</sub> of 15 kΩ to V <sub>SS</sub>	2.8	—	—	
R <sub>PD</sub>	PA11, PA12(USBFS_DM/DP)	V <sub>IN</sub> = V <sub>DD</sub>	14.25	21	24.8	kΩ	
R <sub>PU</sub>	PA12(USBFS_DP)	V <sub>IN</sub> = V <sub>SS</sub>	0.9	1.5	1.85		

(1) Value guaranteed by design, not 100% tested in production.

**Table 4-54. USBFS full speed-electrical characteristics<sup>(1)</sup>**

Symbol	Parameter	Conditions	Min	Typ	Max	Unit
t <sub>R</sub>	Rise time	C <sub>L</sub> = 50 pF	4	—	20	ns
t <sub>F</sub>	Fall time	C <sub>L</sub> = 50 pF	4	—	20	ns
t <sub>RFM</sub>	Rise/ fall time matching	t <sub>R</sub> / t <sub>F</sub>	90	—	110	%
V <sub>CRS</sub>	Output signal crossover voltage	—	1.3	—	2.0	V

(1) Value guaranteed by design, not 100% tested in production.

**Figure 4-19. USBFS timings: definition of data signal rise and fall time**

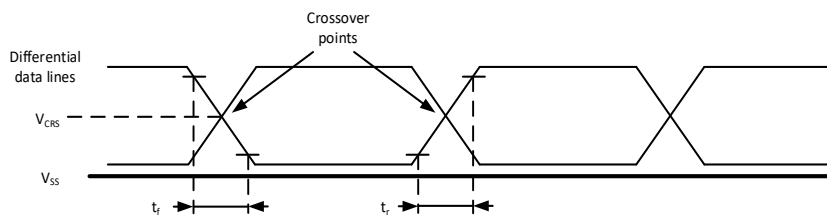

## 4.28. WDGT characteristics

**Table 4-55. FWDGT min/max timeout period at 40 kHz (IRC40K)<sup>(1)</sup>**

Prescaler divider	PSC[3:0] bits	Min timeout RLD[11:0]=	Max timeout RLD[11:0]=	Unit
		0x000	0xFF	
1/4	0000	0.1	409.6	ms
1/8	0001	0.2	819.2	
1/16	0010	0.4	1638.4	
1/32	0011	0.8	3276.8	
1/64	0100	1.6	6553.6	
1/128	0101	3.2	13107.2	
1/256	0110	6.4	26214.4	
1/512	0111	12.8	52,428.8	
1/1024	1000	25.6	104,857.6	
1/2048	1001	51.2	209,715.2	
1/4096	1010	102.4	419,430.4	
1/8192	1011	204.8	838,860.8	
1/16384	1100	409.6	1,677,721.6	
1/32768	1101~1111	819.2	3,355,443.2	

(1) Guaranteed by design, not 100% tested in production

**Table 4-56. WWDGT min-max timeout value at 100 MHz ( $f_{PCLK1}$ )<sup>(1)</sup>**

Prescaler divider	PSC[4:0]	Min timeout value CNT[6:0] = 0x40	Max timeout value CNT[6:0] = 0x7F	Unit
1/1	00000	0.04096	2.6214	ms
1/2	00001	0.08192	5.2429	
1/4	00010	0.16384	10.4858	
1/8	00011	0.32768	20.9715	
1/16	00100	0.6554	41.9430	
1/32	00101	1.3107	83.8861	
1/64	00110	2.6214	167.7722	
1/128	00111	5.2429	335.5443	
1/256	01000	10.4858	671.0886	
1/512	01001	20.9715	1342.1773	
1/1024	01010	41.9430	2684.3546	
1/2048	01011	83.8861	5368.7091	
1/4096	01100	167.7722	10737.4182	
1/8192	01101	335.5443	21474.8365	
1/16384	01110	671.0886	42949.6730	
1/32768	01111	1342.1773	85899.3459	
1/65536	10000	2684.3546	171798.6918	
1/131072	10001	5368.7091	343597.3837	
1/262144	10010~11111	10737.4182	687194.7674	

(1) Guaranteed by design, not 100% tested in production

## 4.29. JTAG Timing

**Table 4-57. JTAG Scan Interface Timing <sup>(1)</sup>**

Symbol	Description	Min	Max	Unit
$t_{C(JTAG)}$	Cycle time, JTAG low and high period	20	—	ns
$t_{SU(TDI/TMS - TCKr)}$	Setup time, TDI, TMS before TCK rise (TCKr)	6	—	ns
$t_{H(TCKr - TDI/TMS)}$	Hold time, TDI, TMS after TCKr	1	—	ns
$t_{H(TCKf - TDO)}$	Hold time, TDO after TCKf	1	—	ns
$t_{D(TCKf - TDO)}$	Delay time, TDO valid after TCK fall (TCKf)	—	6	ns

(1) Guaranteed by design, not 100% tested in production

Figure 4-20. JTAG timing diagram

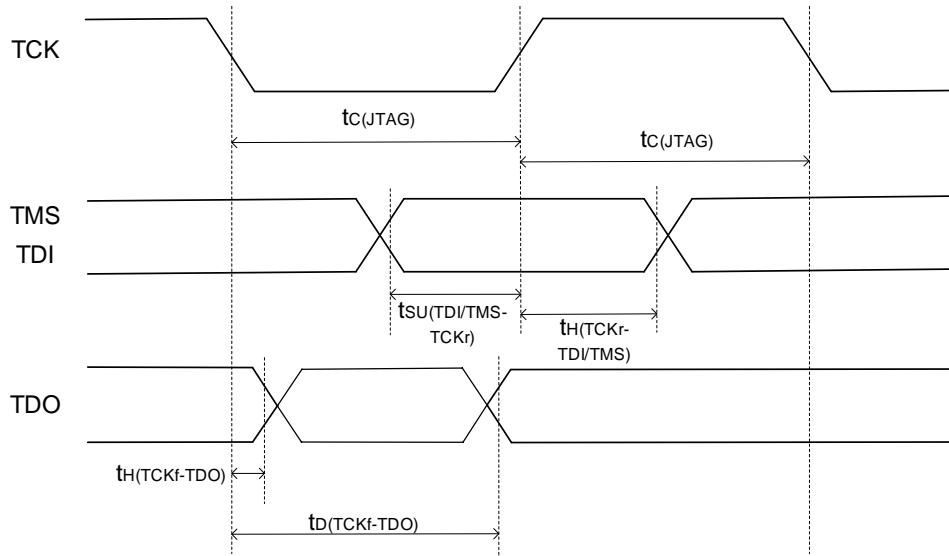

### 4.30. SWD Timing

Table 4-58. SWD Interface Timing <sup>(1)</sup>

Symbol	Description	Min	Max	Unit
$t_{cyc(SWCLK)}$	SWCLK clock cycle time	20	—	ns
$t_{H(SWCLK)}$	SWCLK clock high pulse width	8	—	ns
$t_{L(SWCLK)}$	SWCLK clock low pulse width	8	—	ns
$t_{R(SWCLK)}$	SWCLK clock rise time	—	1	ns
$t_{F(SWCLK)}$	SWCLK clock fall time	—	1	ns
$t_{su(SWD)}$	SWDIO setup time	6	—	ns
$t_{H(SWD)}$	SWDIO hold time	1	—	ns
$t_{D(SWD)}$	SWDIO data delay time	4	6	ns

(1) Guaranteed by design, not 100% tested in production

Figure 4-21. SWD timing diagram

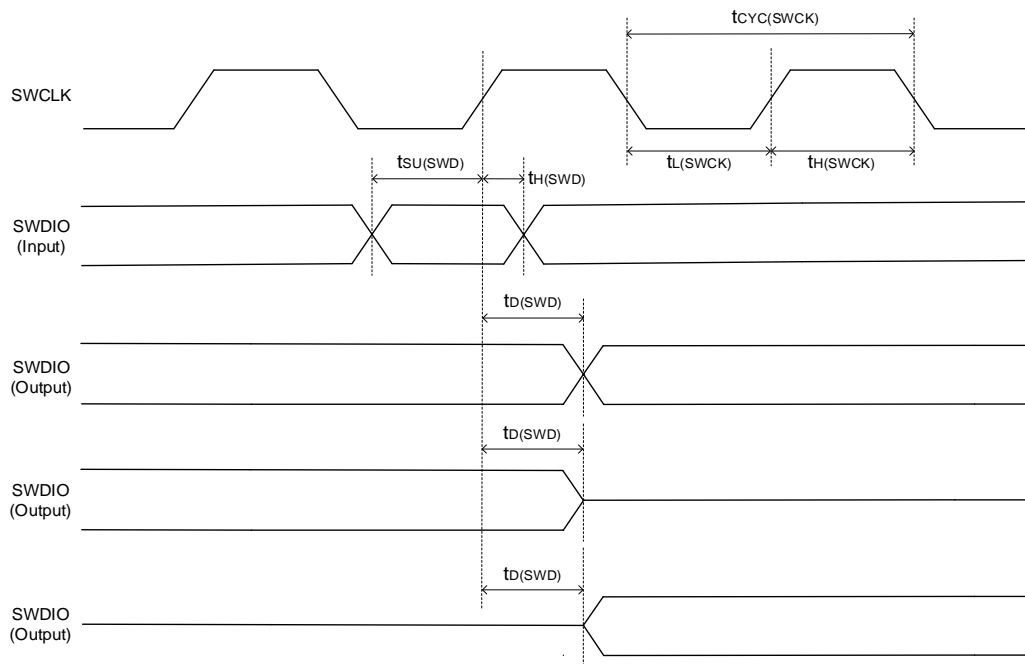

## 5. Package information

### 5.1. LQFP100 package outline dimensions

Figure 5-1. LQFP100 package outline

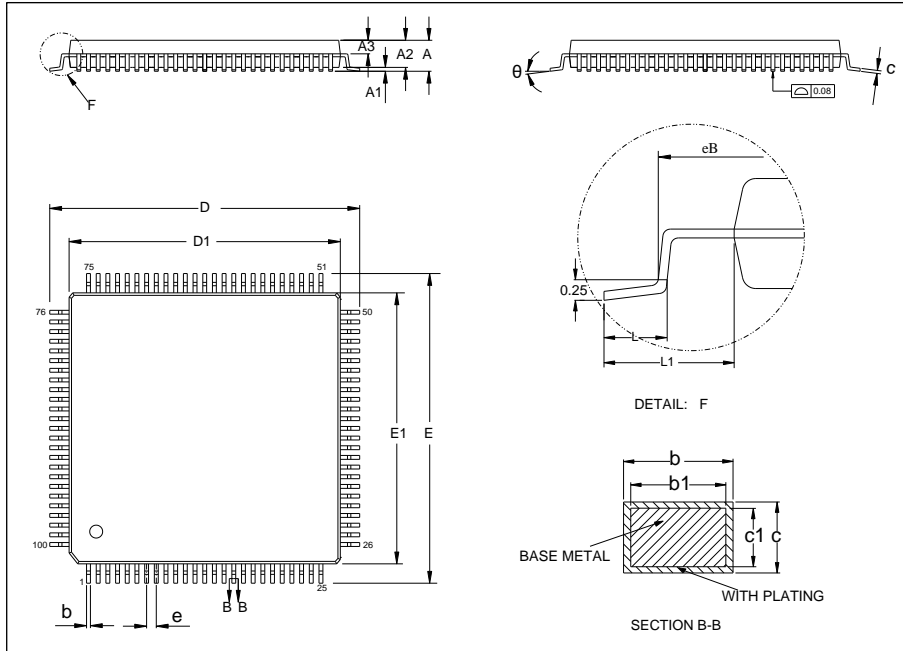
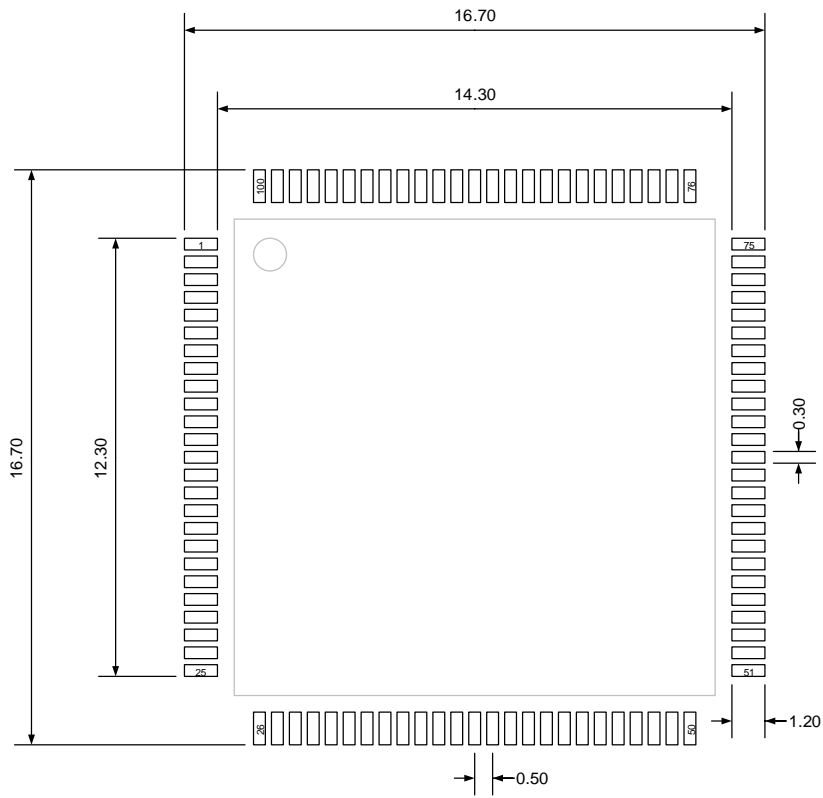

Table 5-1. LQFP100 package dimensions

Symbol	Min	Typ	Max
A	—	—	1.60
A1	0.05	—	0.15
A2	1.35	1.40	1.45
A3	0.59	0.64	0.69
b	0.18	—	0.26
b1	0.17	0.20	0.23
c	0.13	—	0.17
c1	0.12	0.13	0.14
D	15.80	16.00	16.20
D1	13.90	14.00	14.10
E	15.80	16.00	16.20
E1	13.90	14.00	14.10
e	—	0.50	—
eB	15.05	—	15.35
L	0.45	—	0.75
L1	—	1.00	—
θ	0°	—	7°

(Original dimensions are in millimeters)

Figure 5-2. LQFP100 recommended footprint



(Original dimensions are in millimeters)

## 5.2. LQFP64 package outline dimensions

Figure 5-3. LQFP64 package outline

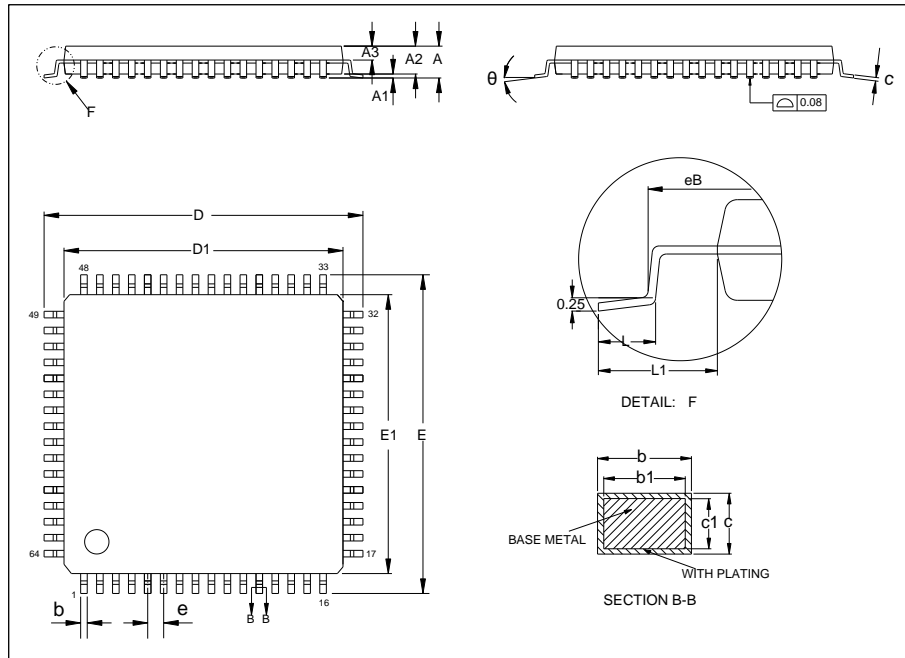
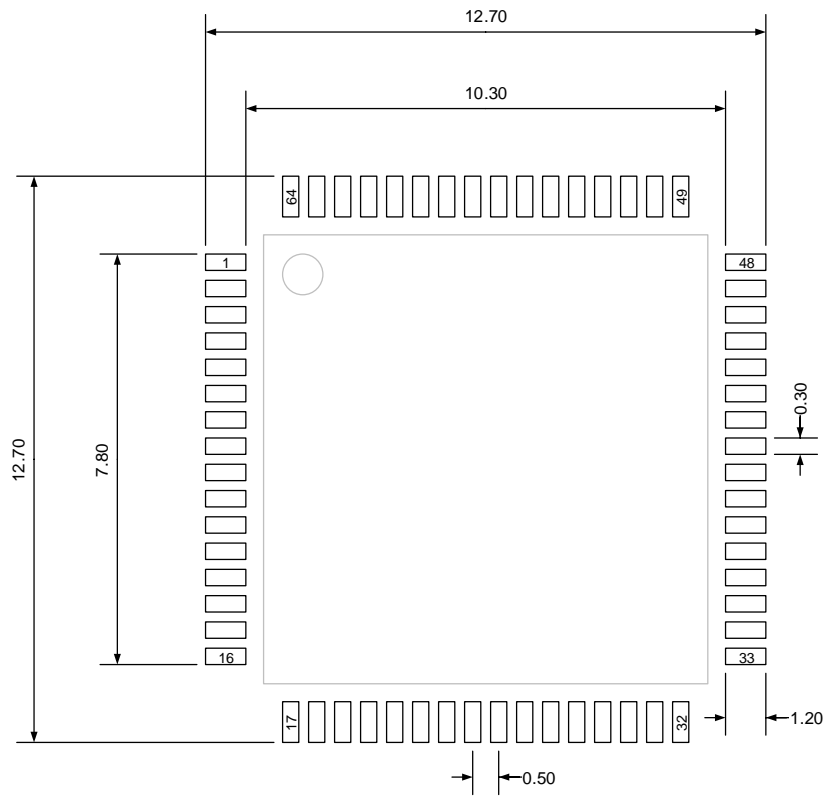

Table 5-2. LQFP64 package dimensions

Symbol	Min	Typ	Max
A	—	—	1.60
A1	0.05	—	0.15
A2	1.35	1.40	1.45
A3	0.59	0.64	0.69
b	0.18	—	0.26
b1	0.17	0.20	0.23
c	0.13	—	0.17
c1	0.12	0.13	0.14
D	11.80	12.00	12.20
D1	9.90	10.00	10.10
E	11.80	12.00	12.20
E1	9.90	10.00	10.10
e	—	0.50	—
eB	11.25	—	11.45
L	0.45	—	0.75
L1	—	1.00	—
$\theta$	0°	—	7°

(Original dimensions are in millimeters)

Figure 5-4. LQFP64 recommended footprint



(Original dimensions are in millimeters)

### 5.3. QFN64 package outline dimensions

Figure 5-5. QFN64 package outline

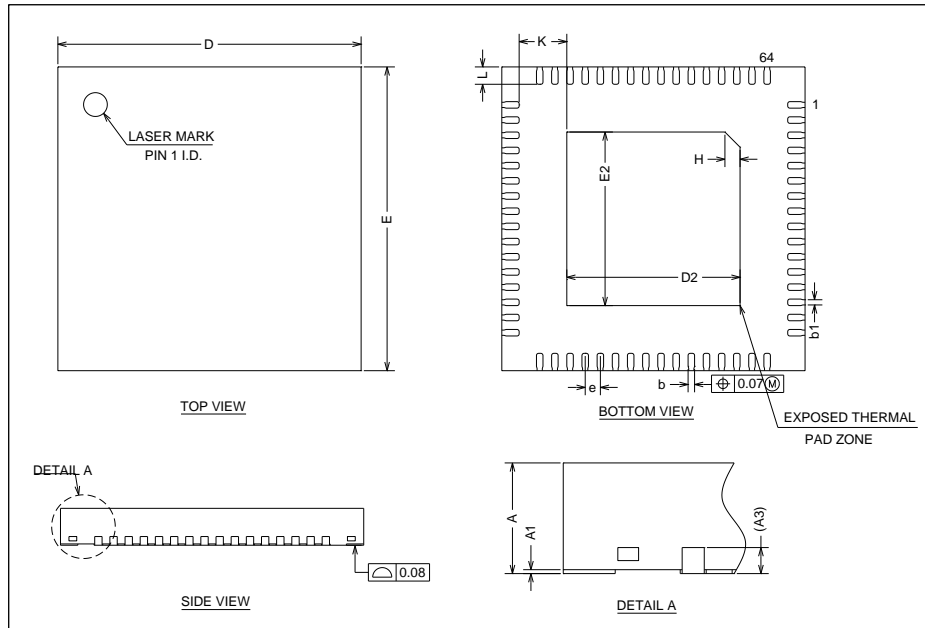
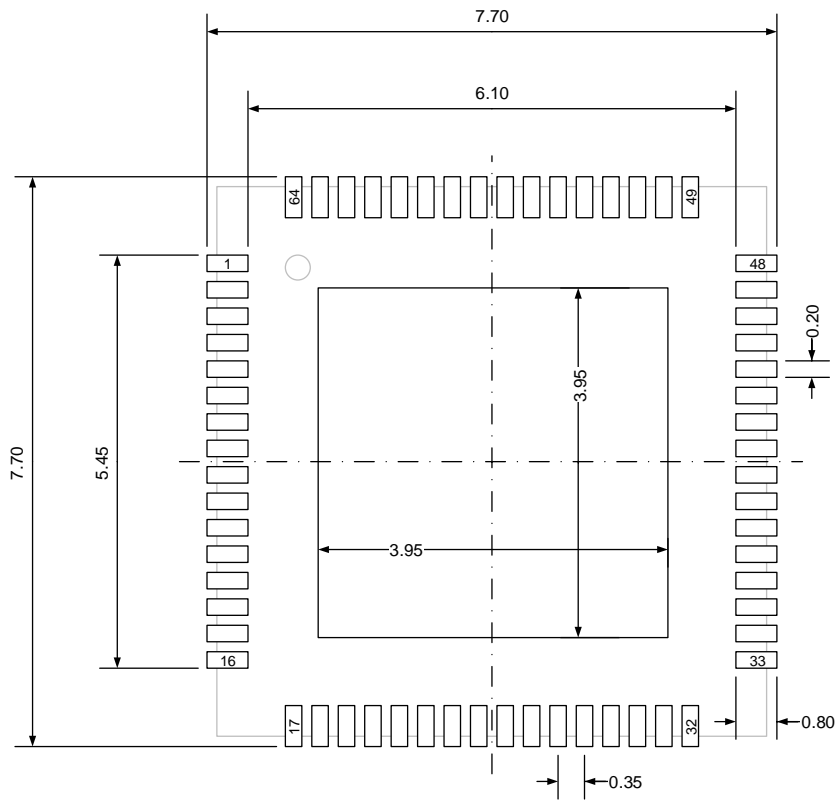

Table 5-3. QFN64 package dimensions

Symbol	Min	Typ	Max
A	0.70	0.75	0.80
A1	0	0.02	0.05
A3	—	0.20	—
b	0.05	0.15	0.20
b1	—	0.12	—
D	6.90	7.00	7.10
D2	3.90	4.00	4.10
E	6.90	7.00	7.10
E2	3.90	4.00	4.10
e	—	0.35	—
H	0.30	0.35	0.40
K	—	1.10	—
L	0.30	0.40	0.50

(Original dimensions are in millimeters)

Figure 5-6. QFN64 recommended footprint



(Original dimensions are in millimeters)

## 5.4. BGA64 package outline dimensions

Figure 5-7. BGA64 package outline

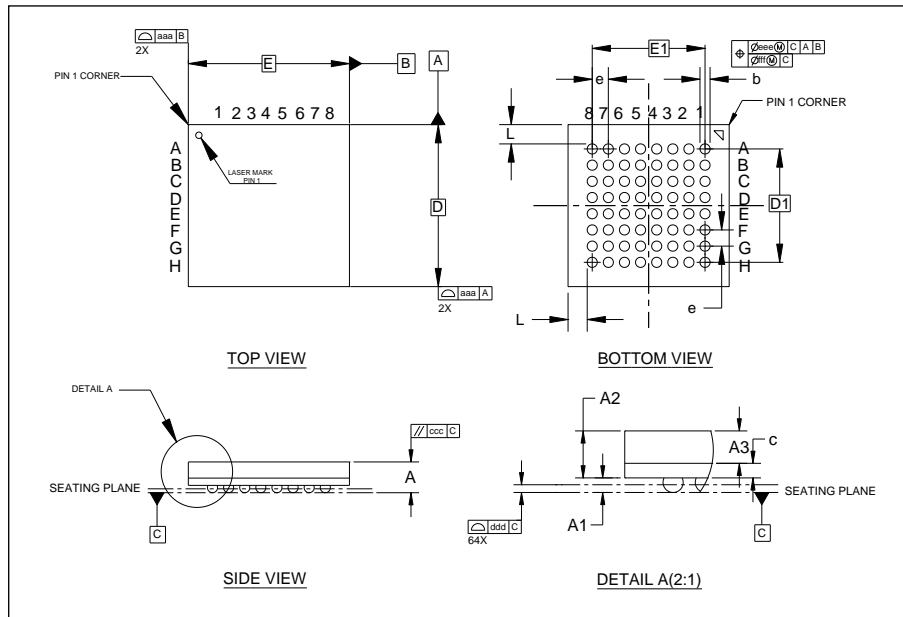
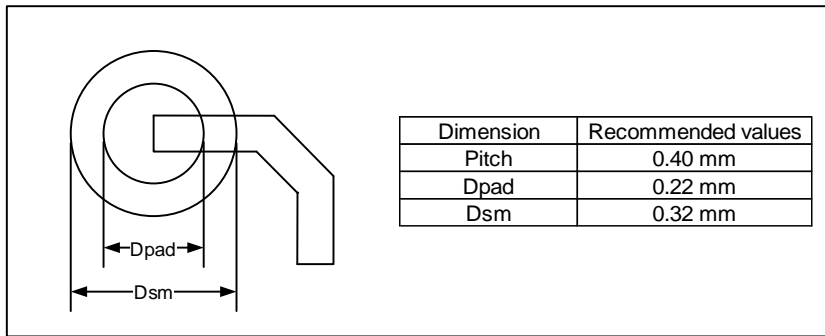

Table 5-4. BGA64 package dimensions

Symbol	Min	Typ	Max
A	0.68	0.76	0.84
A1	0.13	0.18	0.23
A2	0.53	0.58	0.63
A3	—	0.40	—
b	0.20	0.25	0.30
c	0.15	0.18	0.21
D	3.90	4.00	4.10
D1	—	2.80	—
E	3.90	4.00	4.10
E1	—	2.80	—
e	—	0.40	—
L	—	0.475	—
aaa	—	0.10	—
ccc	—	0.10	—
ddd	—	0.08	—
eee	—	0.15	—
fff	—	0.05	—

(Original dimensions are in millimeters)

Figure 5-8. BGA64 recommended footprint



(Original dimensions are in millimeters)

### 5.5. LQFP48 package outline dimensions

Figure 5-9. LQFP48 package outline

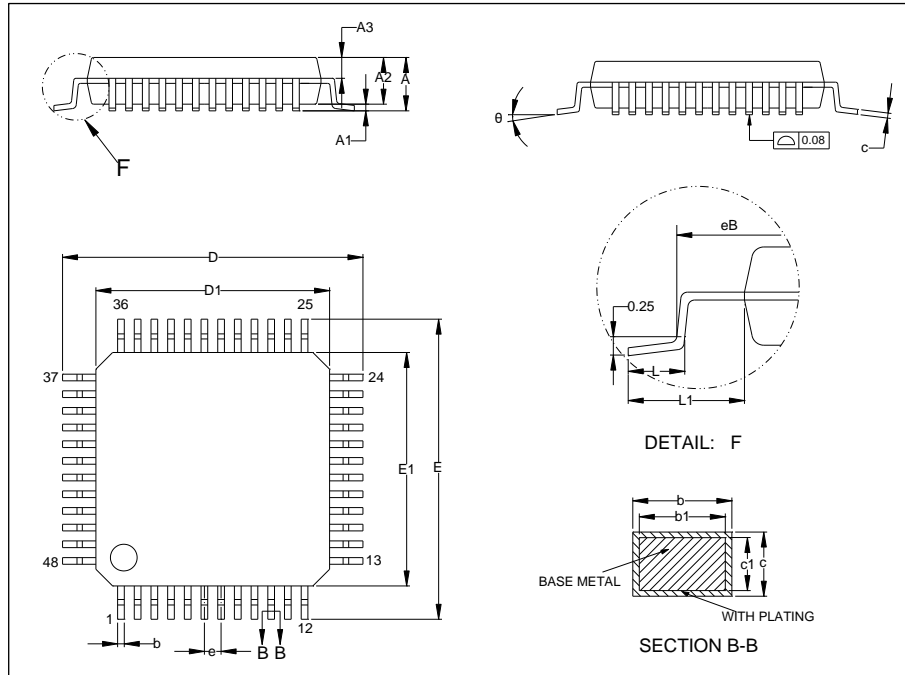
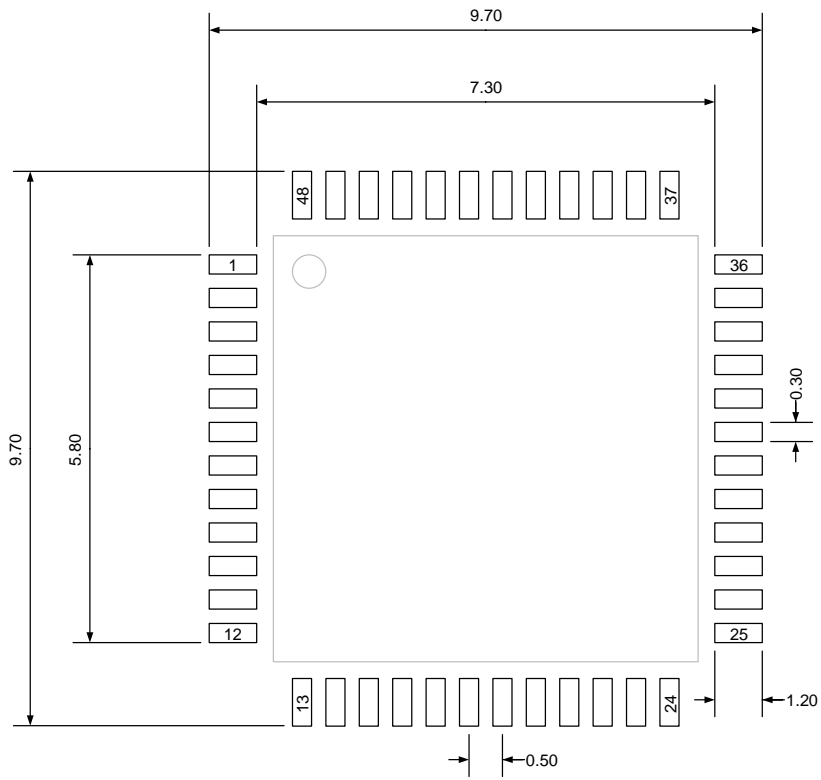

Table 5-5. LQFP48 package dimensions

Symbol	Min	Typ	Max
A	—	—	1.60
A1	0.05	—	0.15
A2	1.35	1.40	1.45
A3	0.59	0.64	0.69
b	0.18	—	0.26
b1	0.17	0.20	0.23
c	0.13	—	0.17
c1	0.12	0.13	0.14
D	8.80	9.00	9.20
D1	6.90	7.00	7.10
E	8.80	9.00	9.20
E1	6.90	7.00	7.10
e	—	0.50	—
eB	8.10	—	8.25
L	0.45	—	0.75
L1	—	1.00	—
$\theta$	0°	—	7°

(Original dimensions are in millimeters)

Figure 5-10. LQFP48 recommended footprint



(Original dimensions are in millimeters)

## 5.6. QFN48 package outline dimensions

Figure 5-11. QFN48 package outline

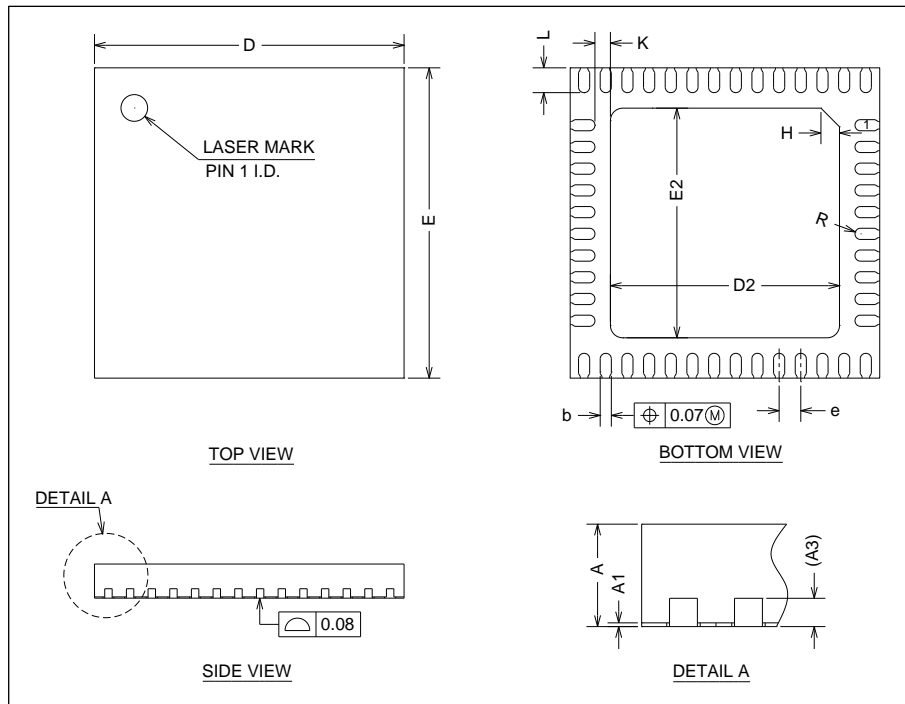
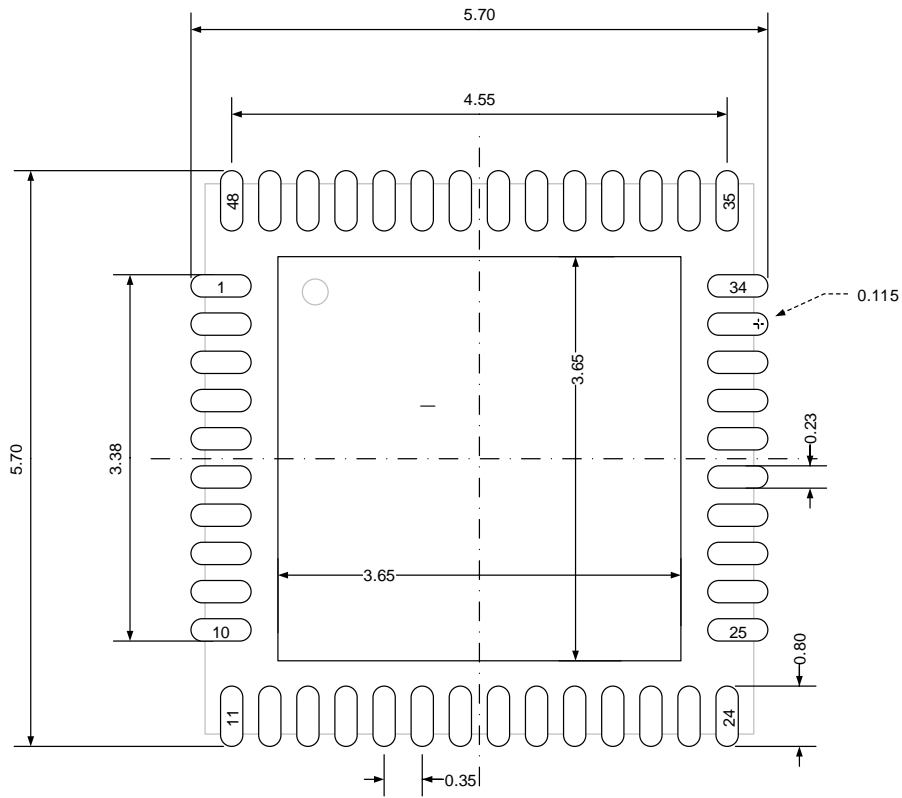

Table 5-6. QFN48 package dimensions

Symbol	Min	Typ	Max
A	0.70	0.75	0.80
A1	0	0.02	0.05
A3	—	0.20	—
b	0.13	0.18	0.23
D	4.90	5.00	5.10
D2	3.60	3.70	3.80
E	4.90	5.00	5.10
E2	3.60	3.70	3.80
e	0.25	0.35	0.45
H	—	0.30	—
K	0.15	—	—
L	0.30	0.40	0.50
R	0.07	—	—

(Original dimensions are in millimeters)

Figure 5-12. QFN48 recommended footprint



(Original dimensions are in millimeters)

## 5.7. QFN32 package outline dimensions

Figure 5-13. QFN32 package outline

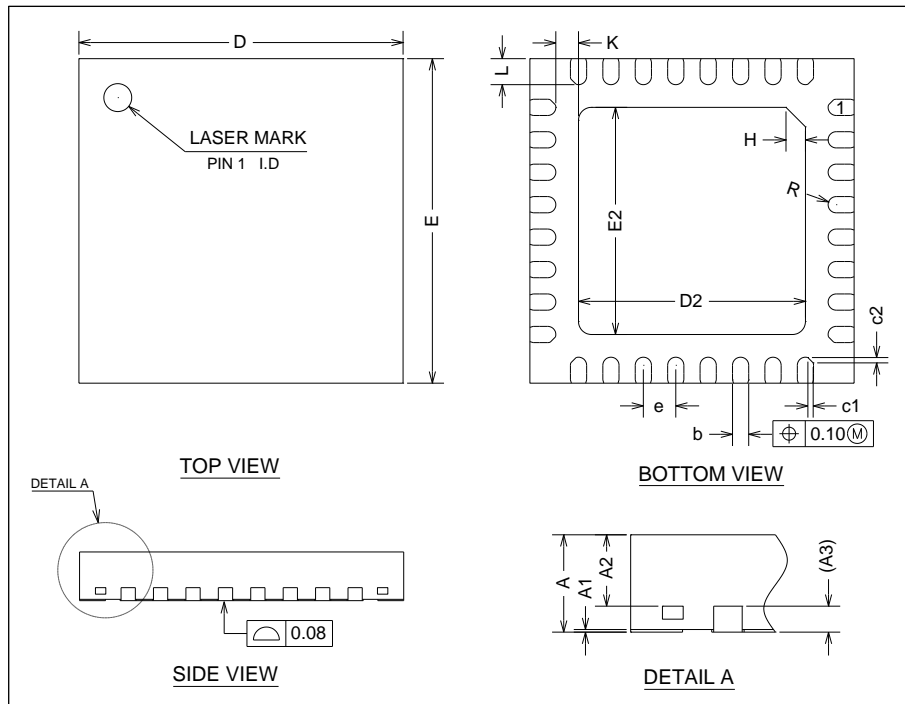
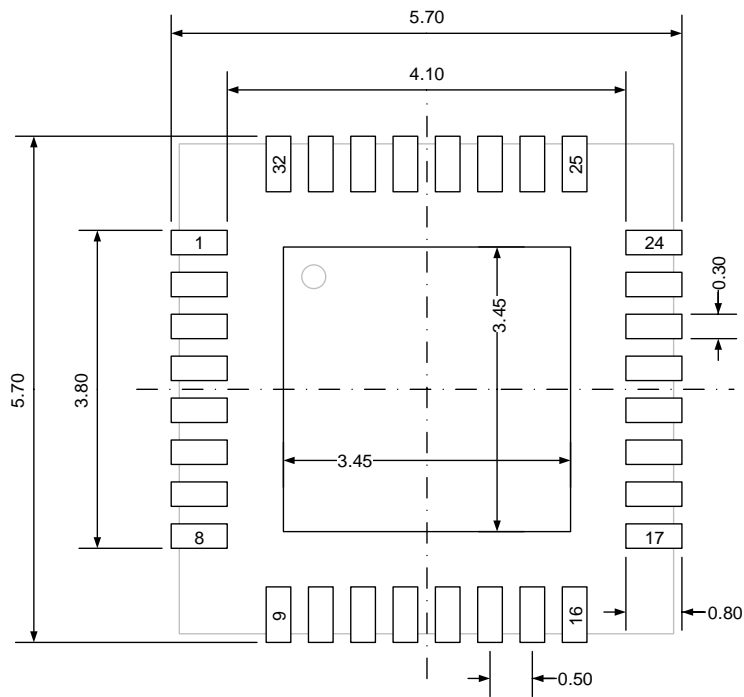

Table 5-7. QFN32 package dimensions

Symbol	Min	Typ	Max
A	0.70	0.75	0.80
A1	0	0.02	0.05
A2	0.50	0.55	0.60
A3	—	0.20	—
b	0.20	0.25	0.30
c1	—	0.08	—
c2	—	0.08	—
D	4.90	5.00	5.10
D2	3.40	3.50	3.60
E	4.90	5.00	5.10
E2	3.40	3.50	3.60
e	0.40	0.50	0.60
H	—	0.30	—
K	—	0.35	—
L	0.30	0.40	0.50
R	0.09	—	—

(Original dimensions are in millimeters)

Figure 5-14. QFN32 recommended footprint



(Original dimensions are in millimeters)

## 5.8. Thermal characteristics

Thermal resistance is used to characterize the thermal performance of the package device, which is represented by the Greek letter “ $\theta$ ”. For semiconductor devices, thermal resistance represents the steady-state temperature rise of the chip junction due to the heat dissipated on the chip surface.

$\theta_{JA}$ : Thermal resistance, junction-to-ambient.

$\theta_{JB}$ : Thermal resistance, junction-to-board.

$\theta_{JC}$ : Thermal resistance, junction-to-case.

$\psi_{JB}$ : Thermal characterization parameter, junction-to-board.

$\psi_{JT}$ : Thermal characterization parameter, junction-to-top center.

$$\theta_{JA}=(T_J-T_A)/P_D \quad (5-1)$$

$$\theta_{JB}=(T_J-T_B)/P_D \quad (5-2)$$

$$\theta_{JC}=(T_J-T_C)/P_D \quad (5-3)$$

Where,  $T_J$  = Junction temperature.

$T_A$  = Ambient temperature

$T_B$  = Board temperature

$T_C$  = Case temperature which is monitoring on package surface

$P_D$  = Total power dissipation

$\theta_{JA}$  represents the resistance of the heat flows from the heating junction to ambient air. It is an indicator of package heat dissipation capability. Lower  $\theta_{JA}$  can be considerate as better overall thermal performance.

$\theta_{JB}$  is used to measure the heat flow resistance between the chip surface and the PCB board.

$\theta_{JC}$  represents the thermal resistance between the chip surface and the package top case.  $\theta_{JC}$  is mainly used to estimate the heat dissipation of the system (using heat sink or other heat dissipation methods outside the device package).

**Table 5-8. Package thermal characteristics<sup>(1)</sup>**

Symbol	Condition	Package	Value	Unit
$\theta_{JA}$	Natural convection, 2S2P PCB	LQFP100	55.78	°C/W
		LQFP64	48.42	
		QFN64	31.01	
		BGA64	78.55	
		LQFP48	55.35	
		QFN48	33.61	

Symbol	Condition	Package	Value	Unit
		QFN32	41.08	
$\theta_{JB}$	Cold plate, 2S2P PCB	LQFP100	36.73	°C/W
		LQFP64	28.17	
		QFN64	19.06	
		BGA64	42.39	
		LQFP48	32.62	
		QFN48	18.43	
		QFN32	20.10	
$\theta_{JC}$	Cold plate, 2S2P PCB	LQFP100	21.18	°C/W
		LQFP64	17.56	
		QFN64	20.73	
		BGA64	27.66	
		LQFP48	20.82	
		QFN48	20.32	
		QFN32	25.02	
$\psi_{JB}$	Natural convection, 2S2P PCB	LQFP100	36.16	°C/W
		LQFP64	27.61	
		QFN64	18.51	
		BGA64	36.70	
		LQFP48	31.98	
		QFN48	17.90	
		QFN32	19.64	
$\psi_{JT}$	Natural convection, 2S2P PCB	LQFP100	1.65	°C/W
		LQFP64	1.49	
		QFN64	0.66	
		BGA64	1.33	
		LQFP48	1.60	
		QFN48	0.65	
		QFN32	0.80	

(1): Thermal characteristics are based on simulation, and meet JEDEC specification.

## 6. Ordering information

**Table 6-1. Part ordering code for GD32F502xx devices**

Ordering code	Flash (KB)	Package	Package type	Temperature operating range
GD32F502VGT6	1024	LQFP100	Green	Industrial -40 °C to +85 °C
GD32F502VET6	512	LQFP100	Green	Industrial -40 °C to +85 °C
GD32F502VCT6	256	LQFP100	Green	Industrial -40 °C to +85 °C
GD32F502RGT6	1024	LQFP64	Green	Industrial -40 °C to +85 °C
GD32F502RET6	512	LQFP64	Green	Industrial -40 °C to +85 °C
GD32F502RCT6	256	LQFP64	Green	Industrial -40 °C to +85 °C
GD32F502RBT6	128	LQFP64	Green	Industrial -40 °C to +85 °C
GD32F502RGO6	1024	QFN64	Green	Industrial -40 °C to +85 °C
GD32F502REO6	512	QFN64	Green	Industrial -40 °C to +85 °C
GD32F502RCO6	256	QFN64	Green	Industrial -40 °C to +85 °C
GD32F502RGL6	1024	BGA64	Green	Industrial -40 °C to +85 °C
GD32F502REL6	512	BGA64	Green	Industrial -40 °C to +85 °C
GD32F502RCL6	256	BGA64	Green	Industrial -40 °C to +85 °C
GD32F502CGT6	1024	LQFP48	Green	Industrial -40 °C to +85 °C
GD32F502CET6	512	LQFP48	Green	Industrial -40 °C to +85 °C
GD32F502CCT6	256	LQFP48	Green	Industrial -40 °C to +85 °C
GD32F502CBT6	128	LQFP48	Green	Industrial -40 °C to +85 °C
GD32F502CGO6	1024	QFN48	Green	Industrial -40 °C to +85 °C
GD32F502CEO6	512	QFN48	Green	Industrial -40 °C to +85 °C
GD32F502CCO6	256	QFN48	Green	Industrial -40 °C to +85 °C
GD32F502KEU6	512	QFN32	Green	Industrial -40 °C to +85 °C
GD32F502KCU6	256	QFN32	Green	Industrial -40 °C to +85 °C
GD32F502KBU6	128	QFN32	Green	Industrial -40 °C to +85 °C

## 7. Revision history

**Table 7-1. Revision history**

Revision No.	Description	Date
0.9RC1	1. Initial Release	Oct.31, 2025
0.9RC2	1. Modify the CPNs of GD32F502xx series. 2. Modify the function description of pin PC14-OSC32IN, PC15-OSC32OUT, OSCIN-PD0 and OSCOUT-PD1. 3. Change all DAC0_OUT1 to DAC0_OUT0.	Dec.2, 2025
0.9RC3	1. Delete CAU, HAU and TRNG.	Dec.9, 2025
0.9RC4	1. Update <b><u>Figure 2-7. GD32F502Cx QFN48 pinouts.</u></b>	Dec.16, 2025
0.9RC5	1. Delete PE2 (TRACECK), PE3 (TRACED0), PE4 (TRACED1), PE5 (TRACED2), PE6 (TRACED3). 2. Change TIMER1_CH0_ETI to TIMER1_CH0 and TIMER1_ETI. 3. Modify description in <b><u>chapter 3.11.</u></b> 4. Modify description in <b><u>chapter 4.13.</u></b>	Jan.20, 2026
0.9RC6	1. Change the description of notice in <b><u>chapter 3.4.</u></b> 2. Modify the parameter VIN in <b><u>Table 4-2.</u></b> 3. Add default function of PA13/PA14/PA15 in <b><u>chapter 2.6.</u></b> 4. Add the number of 5VT GPIO in <b><u>chapter 2.1.</u></b> 5. Modify the number of I2C for QFN32 in <b><u>chapter 2.1.</u></b>	Mar.31, 2026

## Important Notice

This document is the property of GigaDevice Semiconductor Inc. and its subsidiaries (the "Company"). This document, including any product of the Company described in this document (the "Product"), is owned by the Company according to the laws of the People's Republic of China and other applicable laws. The Company reserves all rights under such laws and no Intellectual Property Rights are transferred (either wholly or partially) or licensed by the Company (either expressly or impliedly) herein. The names and brands of third party referred thereto (if any) are the property of their respective owner and referred to for identification purposes only.

To the maximum extent permitted by applicable law, the Company makes no representations or warranties of any kind, express or implied, with regard to the merchantability and the fitness for a particular purpose of the Product, nor does the Company assume any liability arising out of the application or use of any Product. Any information provided in this document is provided only for reference purposes. It is the sole responsibility of the user of this document to determine whether the Product is suitable and fit for its applications and products planned, and properly design, program, and test the functionality and safety of its applications and products planned using the Product. The Product is designed, developed, and/or manufactured for ordinary business, industrial, personal, and/or household applications only, and the Product is not designed or intended for use in (i) safety critical applications such as weapons systems, nuclear facilities, atomic energy controller, combustion controller, aeronautic or aerospace applications, traffic signal instruments, pollution control or hazardous substance management; (ii) life-support systems, other medical equipment or systems (including life support equipment and surgical implants); (iii) automotive applications or environments, including but not limited to applications for active and passive safety of automobiles (regardless of front market or aftermarket), for example, EPS, braking, ADAS (camera/fusion), EMS, TCU, BMS, BSG, TPMS, Airbag, Suspension, DMS, ICMS, Domain, ESC, DCDC, e-clutch, advanced-lighting, etc.. Automobile herein means a vehicle propelled by a self-contained motor, engine or the like, such as, without limitation, cars, trucks, motorcycles, electric cars, and other transportation devices; and/or (iv) other uses where the failure of the device or the Product can reasonably be expected to result in personal injury, death, or severe property or environmental damage (collectively "Unintended Uses"). Customers shall take any and all actions to ensure the Product meets the applicable laws and regulations. The Company is not liable for, in whole or in part, and customers shall hereby release the Company as well as its suppliers and/or distributors from, any claim, damage, or other liability arising from or related to all Unintended Uses of the Product. Customers shall indemnify and hold the Company, and its officers, employees, subsidiaries, affiliates as well as its suppliers and/or distributors harmless from and against all claims, costs, damages, and other liabilities, including claims for personal injury or death, arising from or related to any Unintended Uses of the Product.

Information in this document is provided solely in connection with the Product. The Company reserves the right to make changes, corrections, modifications or improvements to this document and the Product described herein at any time without notice. The Company shall have no responsibility whatsoever for conflicts or incompatibilities arising from future changes to them. Information in this document supersedes and replaces information previously supplied in any prior versions of this document.