

**GigaDevice Semiconductor Inc.**

**GD32F450xx**

**Arm<sup>®</sup> Cortex<sup>®</sup>-M4 32-bit MCU**

**Datasheet**

Revision 2.9

(Jan. 2026)

## Table of Contents

<b>Table of Contents .....</b>	<b>1</b>
<b>List of Figures .....</b>	<b>4</b>
<b>List of Tables .....</b>	<b>5</b>
<b>1. General description .....</b>	<b>7</b>
<b>2. Device overview .....</b>	<b>8</b>
<b>2.1. Device information .....</b>	<b>8</b>
<b>2.2. Block diagram .....</b>	<b>10</b>
<b>2.3. Pinouts and pin assignment.....</b>	<b>11</b>
<b>2.4. Memory map.....</b>	<b>13</b>
<b>2.5. Clock tree.....</b>	<b>17</b>
<b>2.6. Pin definitions .....</b>	<b>18</b>
2.6.1. GD32F450Ix BGA176 pin definitions.....	18
2.6.2. GD32F450Zx LQFP144 pin definitions.....	29
2.6.3. GD32F450Vx LQFP100 pin definitions .....	38
2.6.4. GD32F450xx pin alternate functions .....	46
<b>3. Functional description .....</b>	<b>55</b>
<b>3.1. Arm® Cortex®-M4 core.....</b>	<b>55</b>
<b>3.2. On-chip memory.....</b>	<b>55</b>
<b>3.3. Clock, reset and supply management .....</b>	<b>56</b>
<b>3.4. Boot modes .....</b>	<b>57</b>
<b>3.5. Power saving modes.....</b>	<b>57</b>
<b>3.6. Analog to digital converter (ADC) .....</b>	<b>57</b>
<b>3.7. Digital to analog converter (DAC) .....</b>	<b>58</b>
<b>3.8. DMA.....</b>	<b>58</b>
<b>3.9. General-purpose inputs/outputs (GPIOs).....</b>	<b>59</b>
<b>3.10. Timers and PWM generation .....</b>	<b>59</b>
<b>3.11. Real time clock (RTC) and backup registers .....</b>	<b>60</b>
<b>3.12. Inter-integrated circuit (I2C) .....</b>	<b>61</b>
<b>3.13. Serial peripheral interface (SPI) .....</b>	<b>61</b>
<b>3.14. Universal synchronous/asynchronous receiver transmitter (USART/UART) ....</b>	<b>61</b>

3.15.	Inter-IC sound (I2S) .....	62
3.16.	Universal serial bus full-speed interface (USBFS).....	62
3.17.	Universal serial bus high-speed interface (USBHS) .....	63
3.18.	Controller area network (CAN) .....	63
3.19.	Ethernet (ENET).....	63
3.20.	External memory controller (EXMC) .....	63
3.21.	Secure digital input and output card interface (SDIO).....	64
3.22.	TFT LCD interface (TLI).....	64
3.23.	Image processing accelerator (IPA).....	64
3.24.	Digital camera interface (DCI).....	65
3.25.	Debug mode .....	65
3.26.	Package and operation temperature.....	65
4.	Electrical characteristics.....	66
4.1.	Absolute maximum ratings .....	66
4.2.	Recommended DC characteristics .....	66
4.3.	Power consumption .....	68
4.4.	EMC characteristics .....	76
4.5.	Power supply supervisor characteristics.....	77
4.6.	Electrical sensitivity.....	79
4.7.	External clock characteristics.....	79
4.8.	Internal clock characteristics .....	81
4.9.	PLL characteristics .....	82
4.10.	Memory characteristics .....	84
4.11.	NRST pin characteristics .....	84
4.12.	GPIO characteristics .....	85
4.13.	ADC characteristics .....	87
4.14.	Temperature sensor characteristics.....	89
4.15.	DAC characteristics .....	89
4.16.	I2C characteristics .....	90
4.17.	SPI characteristics .....	91
4.18.	I2S characteristics.....	93
4.19.	USART characteristics.....	95

---

4.20.	SDIO characteristics .....	95
4.21.	CAN characteristics .....	95
4.22.	USBFS characteristics .....	96
4.23.	USBHS characteristics .....	97
4.24.	EXMC characteristics.....	97
4.25.	TIMER characteristics.....	101
4.26.	DCI characteristics.....	101
4.27.	WDGT characteristics .....	102
4.28.	Parameter conditions.....	102
5.	Package information.....	103
5.1	BGA176 package outline dimensions.....	103
5.2	LQFP144 package outline dimensions .....	105
5.3	LQFP100 package outline dimensions .....	107
5.4	Thermal characteristics .....	109
6.	Ordering information .....	111
7.	Revision history .....	112

## List of Figures

Figure 2-1. GD32F450xx block diagram .....	10
Figure 2-2. GD32F450lx BGA176 pinouts.....	11
Figure 2-3. GD32F450Zx LQFP144 pinouts.....	12
Figure 2-4. GD32F450Vx LQFP100 pinouts.....	13
Figure 2-5. GD32F450xx clock tree.....	17
Figure 4-1. Recommended power supply decoupling capacitors <sup>(1)(2)</sup> .....	67
Figure 4-2. Typical supply current consumption in Run mode .....	74
Figure 4-3. Typical supply current consumption in Sleep mode.....	74
Figure 4-4. Recommended PDR_ON pin circuit .....	78
Figure 4-5. Recommended external NRST pin circuit <sup>(1)</sup> .....	85
Figure 4-6. I/O port AC characteristics definition.....	86
Figure 4-7. I2C bus timing diagram.....	91
Figure 4-8. SPI timing diagram - master mode .....	92
Figure 4-9. SPI timing diagram - slave mode.....	92
Figure 4-10. I2S timing diagram - master mode .....	94
Figure 4-11. I2S timing diagram - slave mode .....	94
Figure 4-12. USBFS timings: definition of data signal rise and fall time .....	96
Figure 5-1. BGA176 package outline .....	103
Figure 5-2. BGA176 recommended footprint.....	104
Figure 5-3. LQFP144 package outline .....	105
Figure 5-4. LQFP144 recommended footprint .....	106
Figure 5-5. LQFP100 package outline .....	107
Figure 5-6. LQFP100 recommended footprint .....	108

## List of Tables

Table 2-1. GD32F450xx devices features and peripheral list.....	8
Table 2-2. GD32F450xx memory map.....	13
Table 2-3. GD32F450Ix BGA176 pin definitions.....	18
Table 2-4. GD32F450Zx LQFP144 pin definitions.....	29
Table 2-5. GD32F450Vx LQFP100 pin definitions.....	38
Table 2-6. Port A alternate functions summary.....	46
Table 2-7. Port B alternate functions summary.....	47
Table 2-8. Port C alternate functions summary.....	48
Table 2-9. Port D alternate functions summary.....	49
Table 2-10. Port E alternate functions summary.....	50
Table 2-11. Port F alternate functions summary.....	51
Table 2-12. Port G alternate functions summary.....	52
Table 2-13. Port H alternate functions summary.....	53
Table 2-14. Port I alternate functions summary.....	54
Table 4-1. Absolute maximum ratings <sup>(1)(4)</sup> .....	66
Table 4-2. DC operating conditions.....	66
Table 4-3. Clock frequency <sup>(1)</sup> .....	67
Table 4-4. Operating conditions at Power up / Power down <sup>(1)</sup> .....	67
Table 4-5. Start-up timings of Operating conditions <sup>(1)(2)(3)</sup> .....	错误!未定义书签。
Table 4-6. Power saving mode wakeup timings characteristics <sup>(1)(2)</sup> .....	67
Table 4-7. Power consumption characteristics <sup>(2)(3)(4)(5)(6)</sup> .....	68
Table 4-8. Peripheral current consumption characteristics <sup>(1)</sup> .....	74
Table 4-9. EMS characteristics <sup>(1)</sup> .....	77
Table 4-10. EMI characteristics <sup>(1)</sup> .....	77
Table 4-11. Power supply supervisor characteristics.....	77
Table 4-12. ESD characteristics <sup>(1)</sup> .....	79
Table 4-13. Static latch-up characteristics <sup>(1)</sup> .....	79
Table 4-14. High speed external clock (HXTAL) generated from a crystal/ceramic characteristics.....	79
Table 4-15. High speed external clock characteristics (HXTAL in bypass mode).....	80
Table 4-16. Low speed external clock (LXTAL) generated from a crystal/ceramic characteristics.....	80
Table 4-17. Low speed external user clock characteristics (LXTAL in bypass mode).....	81
Table 4-18. High speed internal clock (IRC16M) characteristics.....	81
Table 4-19. High speed internal clock (IRC48M) characteristics.....	82
Table 4-20. Low speed internal clock (IRC32K) characteristics.....	82
Table 4-21. PLL characteristics.....	82
Table 4-22. PLLI2S characteristics.....	83
Table 4-23. PLLSAI characteristics.....	83
Table 4-24. PLL spread spectrum clock generation (SSCG) characteristics.....	84
Table 4-25. Flash memory characteristics <sup>(1)</sup> .....	84
Table 4-26. NRST pin characteristics.....	84

Table 4-27. I/O port DC characteristics <sup>(1)(3)</sup> .....	85
Table 4-28. I/O port AC characteristics <sup>(1)(2)</sup> .....	86
Table 4-29. ADC characteristics .....	87
Table 4-30. ADC RAIN max for $f_{ADC} = 40 \text{ MHz}^{(2)}$ .....	87
Table 4-31. ADC dynamic accuracy at $f_{ADC} = 30 \text{ MHz}^{(1)}$ .....	88
Table 4-32. ADC dynamic accuracy at $f_{ADC} = 30 \text{ MHz}^{(1)}$ .....	88
Table 4-33. ADC dynamic accuracy at $f_{ADC} = 36 \text{ MHz}^{(1)}$ .....	88
Table 4-34. ADC dynamic accuracy at $f_{ADC} = 40 \text{ MHz}^{(1)}$ .....	88
Table 4-35. ADC static accuracy at $f_{ADC} = 15 \text{ MHz}^{(1)}$ .....	88
Table 4-36. Temperature sensor characteristics <sup>(1)</sup> .....	89
Table 4-37. DAC characteristics .....	89
Table 4-38. I2C characteristics <sup>(1)(2)</sup> .....	90
Table 4-39. Standard SPI characteristics <sup>(1)</sup> .....	91
Table 4-40. I2S characteristics <sup>(1)(2)</sup> .....	93
Table 4-41. USART characteristics <sup>(1)</sup> .....	95
Table 4-42. SDIO characteristics <sup>(1)(2)</sup> .....	95
Table 4-43. USBFS start up time .....	96
Table 4-44. USBFS DC electrical characteristics .....	96
Table 4-45. USBFS full speed-electrical characteristics <sup>(1)</sup> .....	96
Table 4-46. USBHS clock timing parameters <sup>(1)</sup> .....	97
Table 4-47. USB-ULPI Dynammic characteristics .....	97
Table 4-48. Asynchronous non-multiplexed SRAM/PSRAM/NOR read timings <sup>(1)(2)(3)</sup> .....	97
Table 4-49. Asynchronous non-multiplexed SRAM/PSRAM/NOR write timings <sup>(1)(2)(3)</sup> .....	98
Table 4-50. Asynchronous multiplexed PSRAM/NOR read timings <sup>(1)(2)(3)</sup> .....	98
Table 4-51. Asynchronous multiplexed PSRAM/NOR write timings <sup>(1)(2)(3)</sup> .....	98
Table 4-52. Synchronous multiplexed PSRAM/NOR read timings <sup>(1)(2)(3)</sup> .....	99
Table 4-53. Synchronous multiplexed PSRAM write timings <sup>(1)(2)(3)</sup> .....	99
Table 4-54. Synchronous non-multiplexed PSRAM/NOR read timings <sup>(1)(2)(3)</sup> .....	100
Table 4-55. Synchronous non-multiplexed PSRAM write timings <sup>(1)(2)(3)</sup> .....	100
Table 4-56. TIMER characteristics <sup>(1)</sup> .....	101
Table 4-57. DCI characteristics <sup>(1)</sup> .....	101
Table 4-58. FWDGT min/max timeout period at 32 kHz (IRC32K) <sup>(1)</sup> .....	102
Table 4-59. WWDGT min-max timeout value at 50 MHz ( $f_{PCLK1}$ ) <sup>(1)</sup> .....	102
Table 5-1. BGA176 package dimensions .....	103
Table 5-2. LQFP144 package dimensions .....	105
Table 5-3. LQFP100 package dimensions .....	107
Table 5-4. Package thermal characteristics <sup>(1)</sup> .....	109
Table 6-1. Part ordering code for GD32F450xx devices .....	111
Table 7-1. Revision history .....	112

## 1. General description

The GD32F450xx device belongs to the stretch performance line of GD32 MCU family. It is a new 32-bit general-purpose microcontroller based on the Arm® Cortex®-M4 RISC core with best cost-performance ratio in terms of enhanced processing capacity, reduced power consumption and peripheral set. The Cortex®-M4 core features a Floating Point Unit (FPU) that accelerates single precision floating point math operations and supports all Arm® single precision instructions and data types. It implements a full set of DSP instructions to address digital signal control markets that demand an efficient, easy-to-use blend of control and signal processing capabilities. It also provides a Memory Protection Unit (MPU) and powerful trace technology for enhanced application security and advanced debug support.

The GD32F450xx device incorporates the Arm® Cortex®-M4 32-bit processor core operating at 200 MHz frequency with Flash accesses zero wait states to obtain maximum efficiency. It provides up to 3072 KB on-chip Flash memory and 512 KB SRAM memory. An extensive range of enhanced I/Os and peripherals connected to two APB buses. The devices offer up to three 12-bit 2.6 MSPS ADCs, two 12-bit DACs, up to eight general 16-bit timers, two 16-bit PWM advanced timers, two 32-bit general timers, and two 16-bit basic timers, as well as standard and advanced communication interfaces: up to six SPIs, three I2Cs, four USARTs and four UARTs, two I2Ss, two CANs, a SDIO, USBFS and USBHS, and an ENET. Additional peripherals as Digital camera interface (DCI), EXMC interface with SDRAM extension support, TFT-LCD Interface (TLI) and Image Processing Accelerator (IPA) are included.

The device operates from a 2.6 to 3.6V power supply and available in –40 to +85 °C temperature range for grade 6 devices, and -40 to 105 °C temperature range for grade 7 devices. Three power saving modes provide the flexibility for maximum optimization of power consumption, an especially important consideration in low power applications.

The above features make GD32F450xx devices suitable for a wide range of interconnection and advanced applications, especially in areas such as industrial control, consumer and handheld equipment, embedded modules, human machine interface, security and alarm systems, graphic display, automotive navigation, drone, IoT and so on.



## 2. Device overview

### 2.1. Device information

Table 2-1. GD32F450xx devices features and peripheral list

Part Number		GD32F450xx										
		VE	VG	VI	VK	ZE	ZG	ZI	ZK	IG	II	IK
Flash	Code area (KB)	512	512	256	512	512	512	256	512	512	256	512
	Data area (KB)	0	512	1792	2560	0	512	1792	2560	512	1792	2560
	Total (KB)	512	1024	2048	3072	512	1024	2048	3072	1024	2048	3072
SRAM (KB)		256	256	512	256	256	256	512	256	256	512	256
Timers	General timer(16-bit)	8 <small>(2-3,8-13)</small>	8 <small>(2-3,8-13)</small>	8 <small>(2-3,8-13)</small>	8 <small>(2-3,8-13)</small>	8 <small>(2-3,8-13)</small>	8 <small>(2-3,8-13)</small>	8 <small>(2-3,8-13)</small>	8 <small>(2-3,8-13)</small>	8 <small>(2-3,8-13)</small>	8 <small>(2-3,8-13)</small>	8 <small>(2-3,8-13)</small>
	General timer(32-bit)	2 <small>(1,4)</small>	2 <small>(1,4)</small>	2 <small>(1,4)</small>	2 <small>(1,4)</small>	2 <small>(1,4)</small>	2 <small>(1,4)</small>	2 <small>(1,4)</small>	2 <small>(1,4)</small>	2 <small>(1,4)</small>	2 <small>(1,4)</small>	2 <small>(1,4)</small>
	Advanced timer(16-bit)	2 <small>(0,7)</small>	2 <small>(0,7)</small>	2 <small>(0,7)</small>	2 <small>(0,7)</small>	2 <small>(0,7)</small>	2 <small>(0,7)</small>	2 <small>(0,7)</small>	2 <small>(0,7)</small>	2 <small>(0,7)</small>	2 <small>(0,7)</small>	2 <small>(0,7)</small>
	Basic timer(16-bit)	2 <small>(5,6)</small>	2 <small>(5,6)</small>	2 <small>(5,6)</small>	2 <small>(5,6)</small>	2 <small>(5,6)</small>	2 <small>(5,6)</small>	2 <small>(5,6)</small>	2 <small>(5,6)</small>	2 <small>(5,6)</small>	2 <small>(5,6)</small>	2 <small>(5,6)</small>
	SysTick	1	1	1	1	1	1	1	1	1	1	1
	Watchdog	2	2	2	2	2	2	2	2	2	2	2
	RTC	1	1	1	1	1	1	1	1	1	1	1
Connectivity	USART	4	4	4	4	4	4	4	4	4	4	4
	UART	4	4	4	4	4	4	4	4	4	4	4
	I2C	3	3	3	3	3	3	3	3	3	3	3
	SPI/I2S	5/2 <small>(0-4)/(1-2)</small>	5/2 <small>(0-4)/(1-2)</small>	5/2 <small>(0-4)/(1-2)</small>	5/2 <small>(0-4)/(1-2)</small>	6/2 <small>(0-5)/(1-2)</small>	6/2 <small>(0-5)/(1-2)</small>	6/2 <small>(0-5)/(1-2)</small>	6/2 <small>(0-5)/(1-2)</small>	6/2 <small>(0-5)/(1-2)</small>	6/2 <small>(0-5)/(1-2)</small>	6/2 <small>(0-5)/(1-2)</small>
	SDIO	1	1	1	1	1	1	1	1	1	1	1
	CAN	2	2	2	2	2	2	2	2	2	2	2
	USB	FS+H S	FS+H S	FS+H S	FS+H S	FS+H S	FS+H S	FS+H S	FS+H S	FS+H S	FS+H S	FS+H S

Part Number		GD32F450xx											
		VE	VG	VI	VK	ZE	ZG	ZI	ZK	IG	II	IK	
ENET		1	1	1	1	1	1	1	1	1	1	1	
TLI		1	1	1	1	1	1	1	1	1	1	1	
DCI		1	1	1	1	1	1	1	1	1	1	1	
GPIO		82	82	82	82	114	114	114	114	140	140	140	
EXMC/SDRAM		1/0	1/0	1/0	1/0	1/1	1/1	1/1	1/1	1/1	1/1	1/1	
ADC(CHs)		3(16)	3(16)	3(16)	3(16)	3(24)	3(24)	3(24)	3(24)	3(24)	3(24)	3(24)	
DAC	Units	1	1	1	1	1	1	1	1	1	1	1	
	Channels	2	2	2	2	2	2	2	2	2	2	2	
Package						LQFP144				BGA176			

## 2.2. Block diagram

Figure 2-1. GD32F450xx block diagram

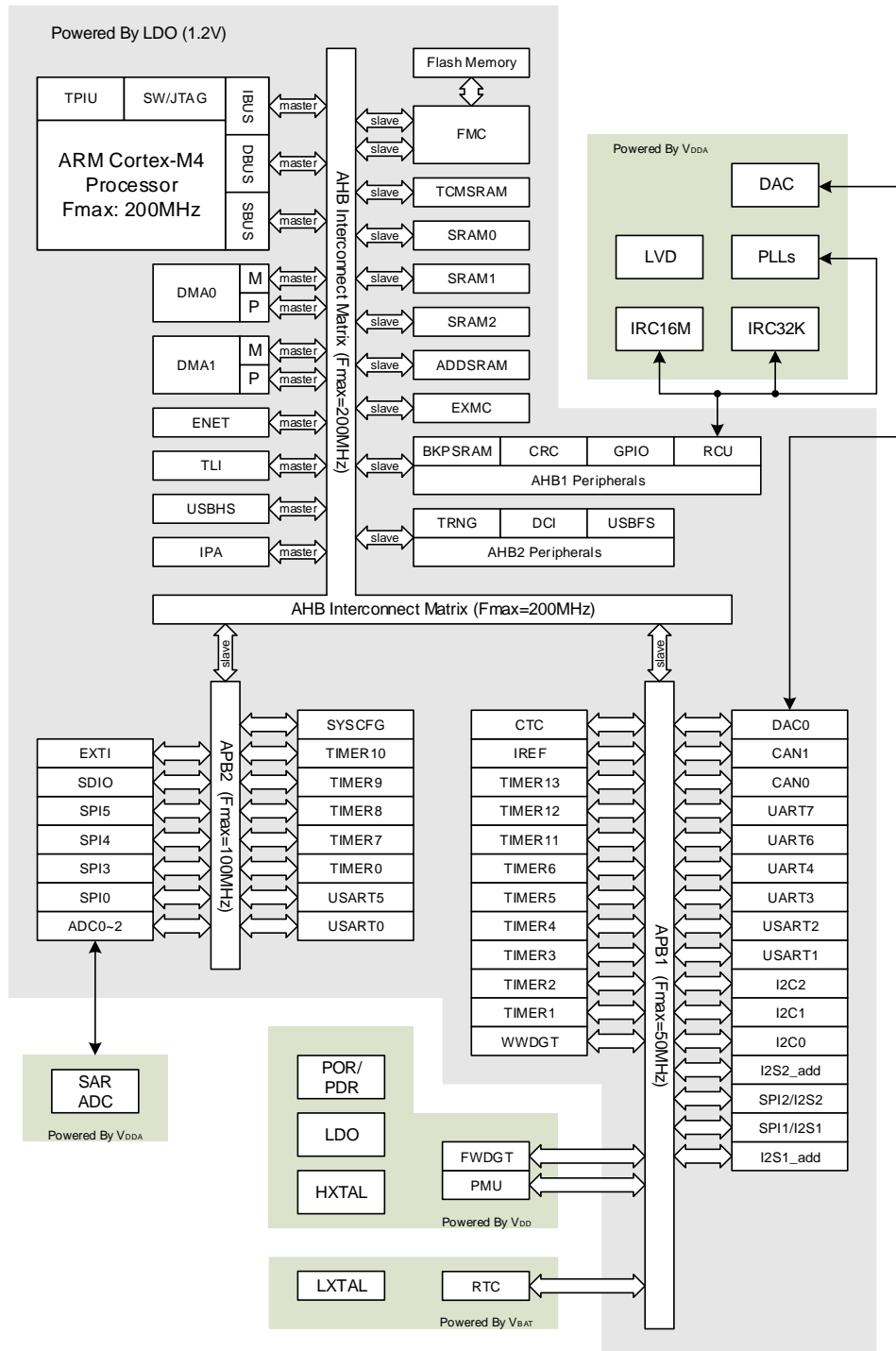

### 2.3. Pinouts and pin assignment

Figure 2-2. GD32F450Ix BGA176 pinouts

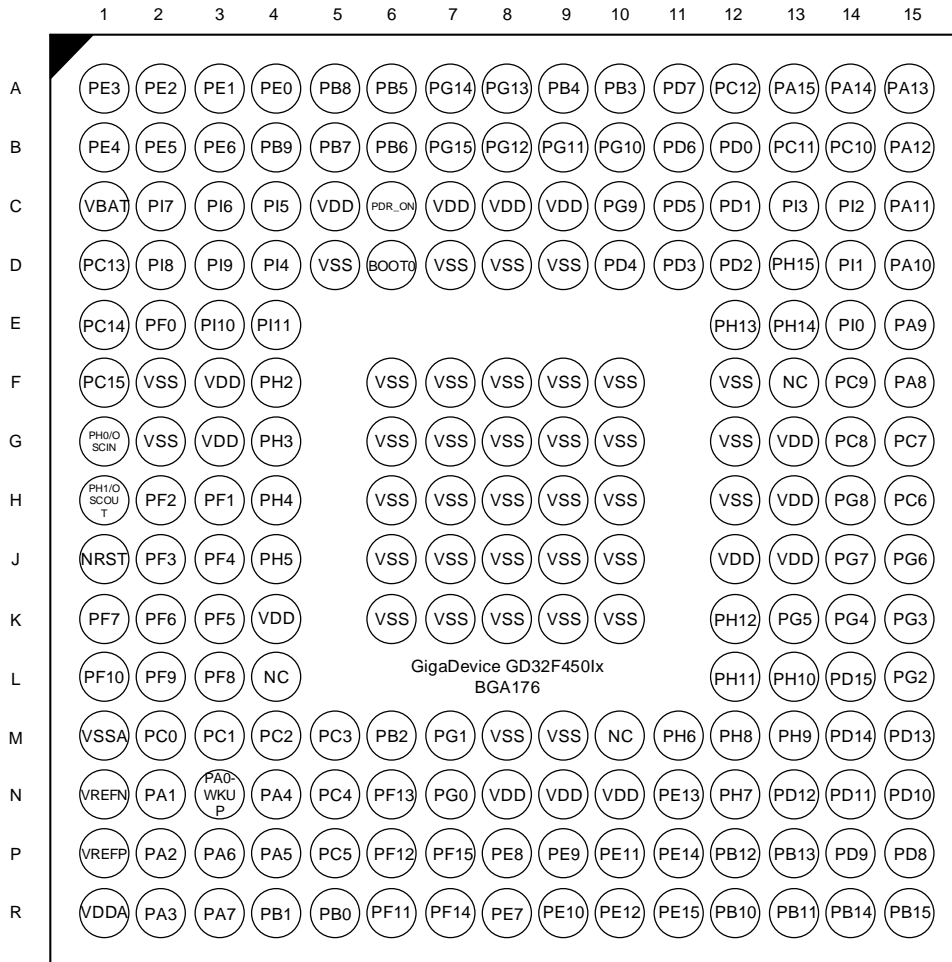
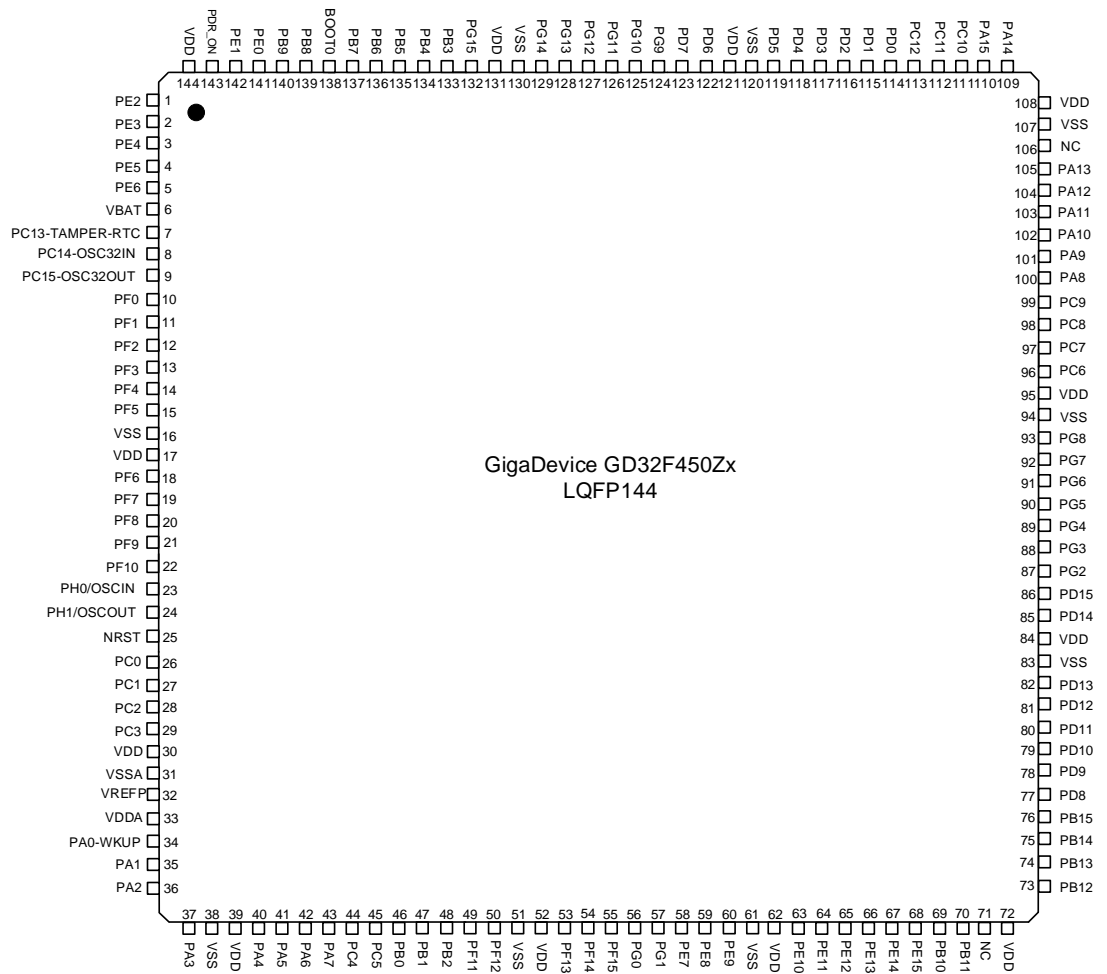

Figure 2-3. GD32F450Zx LQFP144 pinouts





Pre-defined Regions	Bus	Address	Peripherals
		0x4002 BC00 - 0x4003 FFFF	Reserved
		0x4002 B000 - 0x4002 BBFF	IPA
		0x4002 A000 - 0x4002 AFFF	Reserved
		0x4002 8000 - 0x4002 9FFF	ENET
		0x4002 6800 - 0x4002 7FFF	Reserved
		0x4002 6400 - 0x4002 67FF	DMA1
		0x4002 6000 - 0x4002 63FF	DMA0
		0x4002 5000 - 0x4002 5FFF	Reserved
		0x4002 4000 - 0x4002 4FFF	BKP SRAM
		0x4002 3C00 - 0x4002 3FFF	FMC
		0x4002 3800 - 0x4002 3BFF	RCU
		0x4002 3400 - 0x4002 37FF	Reserved
		0x4002 3000 - 0x4002 33FF	CRC
		0x4002 2400 - 0x4002 2FFF	Reserved
		0x4002 2000 - 0x4002 23FF	GPIOI
		0x4002 1C00 - 0x4002 1FFF	GPIOH
		0x4002 1800 - 0x4002 1BFF	GPIOG
		0x4002 1400 - 0x4002 17FF	GPIOF
		0x4002 1000 - 0x4002 13FF	GPIOE
		0x4002 0C00 - 0x4002 0FFF	GPIOD
		0x4002 0800 - 0x4002 0BFF	GPIOC
		0x4002 0400 - 0x4002 07FF	GPIOB
		0x4002 0000 - 0x4002 03FF	GPIOA
		APB2	0x4001 6C00 - 0x4001 FFFF
	0x4001 6800 - 0x4001 6BFF		TLI
	0x4001 5800 - 0x4001 67FF		Reserved
	0x4001 5400 - 0x4001 57FF		SPI5
	0x4001 5000 - 0x4001 53FF		SPI4
	0x4001 4C00 - 0x4001 4FFF		Reserved
	0x4001 4800 - 0x4001 4BFF		TIMER10
	0x4001 4400 - 0x4001 47FF		TIMER9
	0x4001 4000 - 0x4001 43FF		TIMER8
	0x4001 3C00 - 0x4001 3FFF		EXTI
	0x4001 3800 - 0x4001 3BFF		SYSCFG
	0x4001 3400 - 0x4001 37FF		SPI3
	0x4001 3000 - 0x4001 33FF	SPI0	
0x4001 2C00 - 0x4001 2FFF	SDIO		
0x4001 2400 - 0x4001 2BFF	Reserved		
0x4001 2300 - 0x4001 23FF	ADC0 <sup>(1)</sup>		
0x4001 2200 - 0x4001 22FF	ADC2		

Pre-defined Regions	Bus	Address	Peripherals
		0x4001 2100 - 0x4001 21FF	ADC1
		0x4001 2000 - 0x4001 20FF	ADC0
		0x4001 1800 - 0x4001 1FFF	Reserved
		0x4001 1400 - 0x4001 17FF	USART5
		0x4001 1000 - 0x4001 13FF	USART0
		0x4001 0800 - 0x4001 0FFF	Reserved
		0x4001 0400 - 0x4001 07FF	TIMER7
		0x4001 0000 - 0x4001 03FF	TIMER0
	APB1	0x4000 C800 - 0x4000 FFFF	Reserved
		0x4000 C400 - 0x4000 C7FF	IREF
		0x4000 8000 - 0x4000 C3FF	Reserved
		0x4000 7C00 - 0x4000 7FFF	UART7
		0x4000 7800 - 0x4000 7BFF	UART6
		0x4000 7400 - 0x4000 77FF	DAC0
		0x4000 7000 - 0x4000 73FF	PMU
		0x4000 6C00 - 0x4000 6FFF	CTC
		0x4000 6800 - 0x4000 6BFF	CAN1
		0x4000 6400 - 0x4000 67FF	CAN0
		0x4000 6000 - 0x4000 63FF	Reserved
		0x4000 5C00 - 0x4000 5FFF	I2C2
		0x4000 5800 - 0x4000 5BFF	I2C1
		0x4000 5400 - 0x4000 57FF	I2C0
		0x4000 5000 - 0x4000 53FF	UART4
		0x4000 4C00 - 0x4000 4FFF	UART3
		0x4000 4800 - 0x4000 4BFF	USART2
		0x4000 4400 - 0x4000 47FF	USART1
		0x4000 4000 - 0x4000 43FF	I2S2_add
		0x4000 3C00 - 0x4000 3FFF	SPI2/I2S2
		0x4000 3800 - 0x4000 3BFF	SPI1/I2S1
		0x4000 3400 - 0x4000 37FF	I2S1_add
		0x4000 3000 - 0x4000 33FF	FWDGT
		0x4000 2C00 - 0x4000 2FFF	WWDGT
		0x4000 2800 - 0x4000 2BFF	RTC
		0x4000 2400 - 0x4000 27FF	Reserved
		0x4000 2000 - 0x4000 23FF	TIMER13
		0x4000 1C00 - 0x4000 1FFF	TIMER12
		0x4000 1800 - 0x4000 1BFF	TIMER11
		0x4000 1400 - 0x4000 17FF	TIMER6
		0x4000 1000 - 0x4000 13FF	TIMER5
0x4000 0C00 - 0x4000 0FFF	TIMER4		

Pre-defined Regions	Bus	Address	Peripherals
		0x4000 0800 - 0x4000 0BFF	TIMER3
		0x4000 0400 - 0x4000 07FF	TIMER2
		0x4000 0000 - 0x4000 03FF	TIMER1
SRAM	AHB	0x2007 0000 - 0x3FFF FFFF	Reserved
		0x2003 0000 - 0x2006 FFFF	ADDSRAM(256KB)
		0x2002 0000 - 0x2002 FFFF	SRAM2(64KB)
		0x2001 C000 - 0x2001 FFFF	SRAM1(16KB)
		0x2000 0000 - 0x2001 BFFF	SRAM0(112KB)
Code	AHB	0x1FFF C010 - 0x1FFF FFFF	Reserved
		0x1FFF C000 - 0x1FFF C00F	Option bytes(Bank 0)
		0x1FFF 7A10 - 0x1FFF BFFF	Reserved
		0x1FFF 7800 - 0x1FFF 7A0F	OTP(512B)
		0x1FFF 0000 - 0x1FFF 77FF	Boot loader(30KB)
		0x1FFE C010 - 0x1FFE FFFF	Reserved
		0x1FFE C000 - 0x1FFE C00F	Option bytes(Bank 1)
		0x1001 0000 - 0x1FFE BFFF	Reserved
		0x1000 0000 - 0x1000 FFFF	TCMSRAM(64KB)
		0x0830 0000 - 0x0FFF FFFF	Reserved
		0x0800 0000 - 0x082F FFFF	Main Flash(3072KB)
		0x0000 0000 - 0x07FF FFFF	Aliased to the boot device

**Note:**

(1) ADC\_SSTAT, ADC\_SYNCCTL, ADC\_SYNCDATA based on base address of ADC0.

## 2.5. Clock tree

Figure 2-5. GD32F450xx clock tree

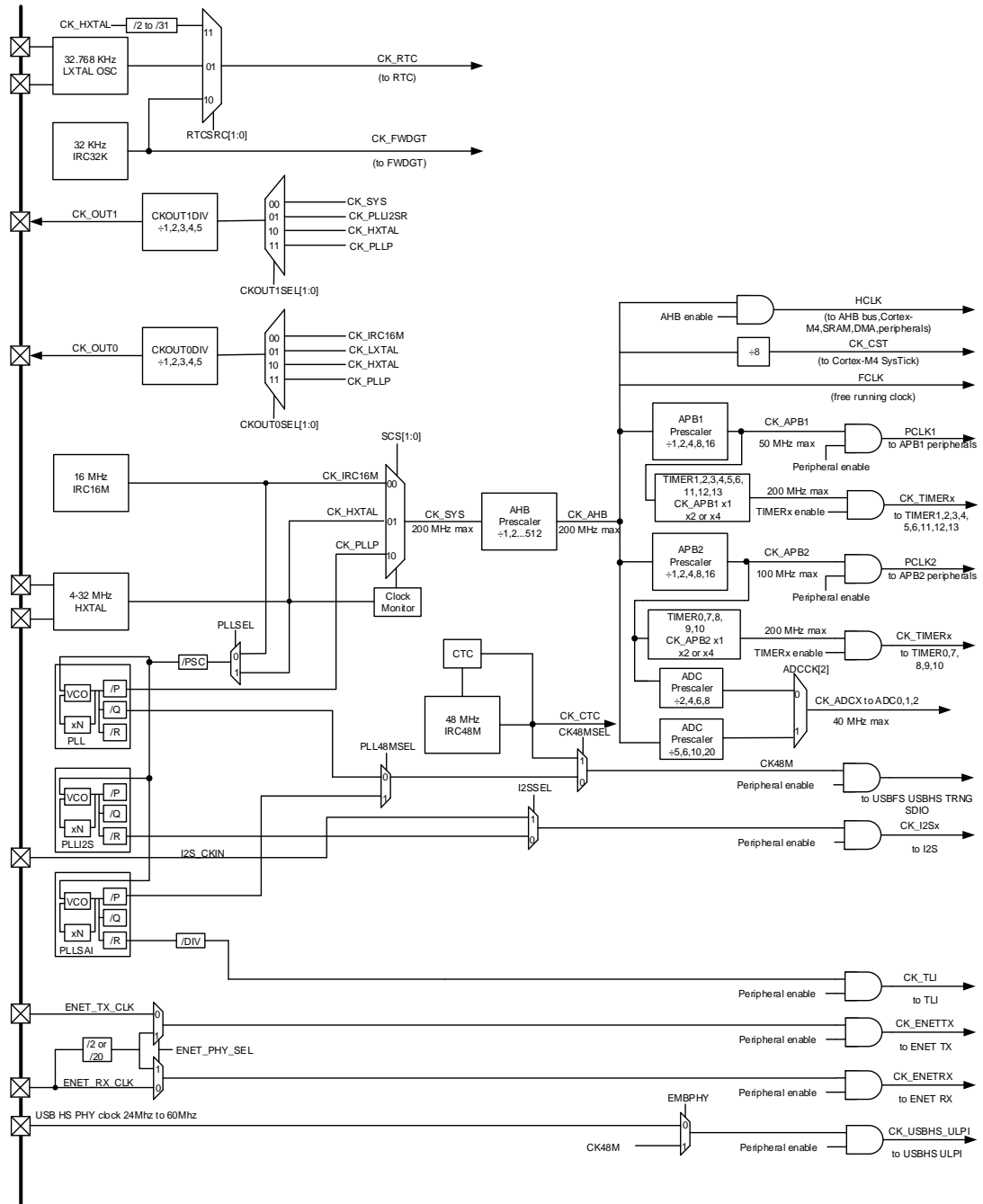

**Legend:**

- HXTAL: High speed crystal oscillator
- LXTAL: Low speed crystal oscillator
- IRC16M: Internal 16M RC oscillators
- IRC32K: Internal 32K RC oscillator
- IRC48M: Internal 48M RC oscillators

## 2.6. Pin definitions

### 2.6.1. GD32F450lx BGA176 pin definitions

**Table 2-3. GD32F450lx BGA176 pin definitions**

GD32F450lx BGA176				
Pin Name	Pins	Pin Type <sup>(1)</sup>	I/O Level <sup>(2)</sup>	Functions description
PE2	A2	I/O	5VT	Default: PE2 Alternate: SPI3_SCK, ENET_MII_TXD3, EXMC_A23, EVENTOUT
PE3	A1	I/O	5VT	Default: PE3 Alternate: EXMC_A19, EVENTOUT
PE4	B1	I/O	5VT	Default: PE4 Alternate: SPI3_NSS, EXMC_A20, DCI_D4, TLI_B0, EVENTOUT
PE5	B2	I/O	5VT	Default: PE5 Alternate: TIMER8_CH0, SPI3_MISO, EXMC_A21, DCI_D6, TLI_G0, EVENTOUT
PE6	B3	I/O	5VT	Default: PE6 Alternate: TIMER8_CH1, SPI3_MOSI, EXMC_A22, DCI_D7, TLI_G1, EVENTOUT
VBAT	C1	P	-	Default: VBAT
PI8	D2	I/O	5VT	Default: PI8 Alternate: EVENTOUT Additional: RTC_TAMP1, RTC_TAMP0, RTC_TS
PC13-TAMPER-RTC	D1	I/O	5VT	Default: PC13 Alternate: EVENTOUT Additional: RTC_TAMP0, RTC_OUT, RTC_TS
PC14-OSC32IN	E1	I/O	5VT	Default: PC14 Alternate: EVENTOUT Additional: OSC32IN
PC15-OSC32OUT	F1	I/O	5VT	Default: PC15 Alternate: EVENTOUT Additional: OSC32OUT
PI9	D3	I/O	5VT	Default: PI9 Alternate: CAN0_RX, EXMC_D30, TLI_VSYNC, EVENTOUT
PI10	E3	I/O	5VT	Default: PI10 Alternate: ENET_MII_RX_ER, EXMC_D31, TLI_HSYNC, EVENTOUT
PI11	E4	I/O	5VT	Default: PI11 Alternate: USBHS_ULPI_DIR, EVENTOUT
VSS	F2	P	-	Default: VSS
VDD	F3	P	-	Default: VDD
PF0	E2	I/O	5VT	Default: PF0

GD32F450xx BGA176				
Pin Name	Pins	Pin Type <sup>(1)</sup>	I/O Level <sup>(2)</sup>	Functions description
				Alternate: I2C1_SDA, EXMC_A0, EVENTOUT, CTC_SYNC
PF1	H3	I/O	5VT	Default: PF1 Alternate: I2C1_SCL, EXMC_A1, EVENTOUT
PF2	H2	I/O	5VT	Default: PF2 Alternate: I2C1_SMBA, EXMC_A2, EVENTOUT
PF3	J2	I/O	5VT	Default: PF3 Alternate: EXMC_A3, EVENTOUT, I2C1_TXFRAME Additional: ADC2_IN9
PF4	J3	I/O	5VT	Default: PF4 Alternate: EXMC_A4, EVENTOUT Additional: ADC2_IN14
PF5	K3	I/O	5VT	Default: PF5 Alternate: EXMC_A5, EVENTOUT Additional: ADC2_IN15
VSS	G2	P	-	Default: VSS
VDD	G3	P	-	Default: VDD
PF6	K2	I/O	5VT	Default: PF6 Alternate: TIMER9_CH0, SPI4_NSS, UART6_RX, EXMC_NIORD, EVENTOUT Additional: ADC2_IN4
PF7	K1	I/O	5VT	Default: PF7 Alternate: TIMER10_CH0, SPI4_SCK, UART6_TX, EXMC_NREG, EVENTOUT Additional: ADC2_IN5
PF8	L3	I/O	5VT	Default: PF8 Alternate: SPI4_MISO, TIMER12_CH0, EXMC_NIOWR, EVENTOUT Additional: ADC2_IN6
PF9	L2	I/O	5VT	Default: PF9 Alternate: SPI4_MOSI, TIMER13_CH0, EXMC_CD, EVENTOUT Additional: ADC2_IN7
PF10	L1	I/O	5VT	Default: PF10 Alternate: EXMC_INTR, DCI_D11, TLI_DE, EVENTOUT Additional: ADC2_IN8
PH0/OSCIN	G1	I/O	5VT	Default: PH0, OSCIN Alternate: EVENTOUT Additional: OSCIN
PH1/OSCOUT	H1	I/O	5VT	Default: PH1, OSCOUT Alternate: EVENTOUT Additional: OSCOUT
NRST	J1	-	-	Default: NRST
PC0	M2	I/O	5VT	Default: PC0 Alternate: USBHS_ULPI_STP, EXMC_SDNWE, EVENTOUT

GD32F450xx BGA176				
Pin Name	Pins	Pin Type <sup>(1)</sup>	I/O Level <sup>(2)</sup>	Functions description
				Additional: ADC012_IN10
PC1	M3	I/O	5VT	Default: PC1 Alternate: SPI2_MOSI, I2S2_SD, SPI1_MOSI, I2S1_SD, ENET_MDC, EVENTOUT Additional: ADC012_IN11
PC2	M4	I/O	5VT	Default: PC2 Alternate: SPI1_MISO, I2S1_ADD_SD, USBHS_ULPI_DIR, ENET_MII_TXD2, EXMC_SDNE0, EVENTOUT Additional: ADC012_IN12
PC3	M5	I/O	5VT	Default: PC3 Alternate: SPI1_MOSI, I2S1_SD, USBHS_ULPI_NXT, ENET_MII_TX_CLK, EXMC_SDCKE0, EVENTOUT Additional: ADC012_IN13
VDD	G3	P	-	Default: VDD
VSSA	M1	P	-	Default: VSSA
VREFN	N1	P	-	Default: VREFN
VREFP	P1	P	-	Default: VREFP
VDDA	R1	P	-	Default: VDDA
PA0-WKUP	N3	I/O	5VT	Default: PA0 Alternate: TIMER1_CH0, TIMER1_ETI, TIMER4_CH0, TIMER7_ETI, USART1_CTS, UART3_TX, ENET_MII_CRS, EVENTOUT Additional: ADC012_IN0, WKUP
PA1	N2	I/O	5VT	Default: PA1 Alternate: TIMER1_CH1, TIMER4_CH1, SPI3_MOSI, USART1_RTS, UART3_RX, ENET_MII_RX_CLK, ENET_RMII_REF_CLK, EVENTOUT Additional: ADC012_IN1
PA2	P2	I/O	5VT	Default: PA2 Alternate: TIMER1_CH2, TIMER4_CH2, TIMER8_CH0, I2S_CKIN, USART1_TX, ENET_MDIO, EVENTOUT Additional: ADC012_IN2
PH2	F4	I/O	5VT	Default: PH2 Alternate: ENET_MII_CRS, EXMC_SDCKE0, TLI_R0, EVENTOUT
PH3	G4	I/O	5VT	Default: PH3 Alternate: ENET_MII_COL, EXMC_SDNE0, TLI_R1, EVENTOUT, I2C1_TXFRAME
PH4	H4	I/O	5VT	Default: PH4 Alternate: I2C1_SCL, USBHS_ULPI_NXT, EVENTOUT
PH5	J4	I/O	5VT	Default: PH5 Alternate: I2C1_SDA, SPI4_NSS, EXMC_SDNWE, EVENTOUT
PA3	R2	I/O	5VT	Default: PA3

GD32F450xx BGA176				
Pin Name	Pins	Pin Type <sup>(1)</sup>	I/O Level <sup>(2)</sup>	Functions description
				Alternate: TIMER1_CH3, TIMER4_CH3, TIMER8_CH1, I2S1_MCK, USART1_RX, USBHS_ULPI_D0, ENET_MII_COL, TLI_B5, EVENTOUT Additional: ADC012_IN3
NC	L4	-	-	-
VDD	K4	P	-	Default: VDD
PA4	N4	I/O		Default: PA4 Alternate: SPI0_NSS, SPI2_NSS, I2S2_WS, USART1_CK, USBHS_SOF, DCI_HSYNC, TLI_VSYNC, EVENTOUT Additional: ADC01_IN4, DAC0_OUT0
PA5	P4	I/O		Default: PA5 Alternate: TIMER1_CH0, TIMER1_ETI, TIMER7_CH0_ON, SPI0_SCK, USBHS_ULPI_CK, EVENTOUT Additional: ADC01_IN5, DAC0_OUT1
PA6	P3	I/O	5VT	Default: PA6 Alternate: TIMER0_BRKIN, TIMER2_CH0, TIMER7_BRKIN, SPI0_MISO, I2S1_MCK, TIMER12_CH0, SDIO_CMD, DCI_PIXCLK, TLI_G2, EVENTOUT Additional: ADC01_IN6
PA7	R3	I/O	5VT	Default: PA7 Alternate: TIMER0_CH0_ON, TIMER2_CH1, TIMER7_CH0_ON, SPI0_MOSI, TIMER13_CH0, ENET_MII_RX_DV, ENET_RMII_CRS_DV, EXMC_SDNWE, EVENTOUT Additional: ADC01_IN7
PC4	N5	I/O	5VT	Default: PC4 Alternate: ENET_MII_RXD0, ENET_RMII_RXD0, EXMC_SDNE0, EVENTOUT Additional: ADC01_IN14
PC5	P5	I/O	5VT	Default: PC5 Alternate: USART2_RX, ENET_MII_RXD1, ENET_RMII_RXD1, EXMC_SDCKE0, EVENTOUT Additional: ADC01_IN15
PB0	R5	I/O	5VT	Default: PB0 Alternate: TIMER0_CH1_ON, TIMER2_CH2, TIMER7_CH1_ON, SPI4_SCK, SPI2_MOSI, I2S2_SD, TLI_R3, USBHS_ULPI_D1, ENET_MII_RXD2, SDIO_D1, EVENTOUT Additional: ADC01_IN8, IREF
PB1	R4	I/O	5VT	Default: PB1 Alternate: TIMER0_CH2_ON, TIMER2_CH3, TIMER7_CH2_ON, SPI4_NSS, TLI_R6, USBHS_ULPI_D2, ENET_MII_RXD3, SDIO_D2, EVENTOUT Additional: ADC01_IN9
PB2	M6	I/O	5VT	Default: PB2, BOOT1

GD32F450xx BGA176				
Pin Name	Pins	Pin Type <sup>(1)</sup>	I/O Level <sup>(2)</sup>	Functions description
				Alternate: TIMER1_CH3, SPI2_MOSI, I2S2_SD, USBHS_ULPI_D4, SDIO_CK, EVENTOUT
PF11	R6	I/O	5VT	Default: PF11 Alternate: SPI4_MOSI, EXMC_SDNRAS, DCI_D12, EVENTOUT
PF12	P6	I/O	5VT	Default: PF12 Alternate: EXMC_A6, EVENTOUT
VSS	M8	P	-	Default: VSS
VDD	N8	P	-	Default: VDD
PF13	N6	I/O	5VT	Default: PF13 Alternate: EXMC_A7, EVENTOUT
PF14	R7	I/O	5VT	Default: PF14 Alternate: EXMC_A8, EVENTOUT
PF15	P7	I/O	5VT	Default: PF15 Alternate: EXMC_A9, EVENTOUT
PG0	N7	I/O	5VT	Default: PG0 Alternate: EXMC_A10, EVENTOUT
PG1	M7	I/O	5VT	Default: PG1 Alternate: EXMC_A11, EVENTOUT
PE7	R8	I/O	5VT	Default: PE7 Alternate: TIMER0_ETI, UART6_RX, EXMC_D4, EVENTOUT
PE8	P8	I/O	5VT	Default: PE8 Alternate: TIMER0_CH0_ON, UART6_TX, EXMC_D5, EVENTOUT
PE9	P9	I/O	5VT	Default: PE9 Alternate: TIMER0_CH0, EXMC_D6, EVENTOUT
VSS	M9	P	-	Default: VSS
VDD	N9	P	-	Default: VDD
PE10	R9	I/O	5VT	Default: PE10 Alternate: TIMER0_CH1_ON, EXMC_D7, EVENTOUT
PE11	P10	I/O	5VT	Default: PE11 Alternate: TIMER0_CH1, SPI3_NSS, SPI4_NSS, EXMC_D8, TLI_G3, EVENTOUT
PE12	R10	I/O	5VT	Default: PE12 Alternate: TIMER0_CH2_ON, SPI3_SCK, SPI4_SCK, EXMC_D9, TLI_B4, EVENTOUT
PE13	N11	I/O	5VT	Default: PE13 Alternate: TIMER0_CH2, SPI3_MISO, SPI4_MISO, EXMC_D10, TLI_DE, EVENTOUT
PE14	P11	I/O	5VT	Default: PE14 Alternate: TIMER0_CH3, SPI3_MOSI, SPI4_MOSI, EXMC_D11, TLI_PIXCLK, EVENTOUT
PE15	R11	I/O	5VT	Default: PE15

GD32F450xx BGA176				
Pin Name	Pins	Pin Type <sup>(1)</sup>	I/O Level <sup>(2)</sup>	Functions description
				Alternate: TIMER0_BRKIN, EXMC_D12, TLI_R7, EVENTOUT
PB10	R12	I/O	5VT	Default: PB10 Alternate: TIMER1_CH2, I2C1_SCL, SPI1_SCK, I2S1_CK, I2S2_MCK, USART2_TX, USBHS_ULPI_D3, ENET_MII_RX_ER, SDIO_D7, TLI_G4, EVENTOUT
PB11	R13	I/O	5VT	Default: PB11 Alternate: TIMER1_CH3, I2C1_SDA, I2S_CKIN, USART2_RX, USBHS_ULPI_D4, ENET_MII_TX_EN, ENET_RMII_TX_EN, TLI_G5, EVENTOUT
NC	M10	-	-	-
VDD	N10	P	-	Default: VDD
PH6	M11	I/O	5VT	Default: PH6 Alternate: I2C1_SMBA, SPI4_SCK, TIMER11_CH0, ENET_MII_RXD2, EXMC_SDNE1, DCI_D8, EVENTOUT
PH7	N12	I/O	5VT	Default: PH7 Alternate: I2C2_SCL, SPI4_MISO, ENET_MII_RXD3, EXMC_SDCKE1, DCI_D9, EVENTOUT
PH8	M12	I/O	5VT	Default: PH8 Alternate: I2C2_SDA, EXMC_D16, DCI_HSYNC, TLI_R2, EVENTOUT
PH9	M13	I/O	5VT	Default: PH9 Alternate: I2C2_SMBA, TIMER11_CH1, EXMC_D17, DCI_D0, TLI_R3, EVENTOUT
PH10	L13	I/O	5VT	Default: PH10 Alternate: TIMER4_CH0, EXMC_D18, DCI_D1, TLI_R4, EVENTOUT, I2C2_TXFRAME
PH11	L12	I/O	5VT	Default: PH11 Alternate: TIMER4_CH1, EXMC_D19, DCI_D2, TLI_R5, EVENTOUT
PH12	K12	I/O	5VT	Default: PH12 Alternate: TIMER4_CH2, EXMC_D20, DCI_D3, TLI_R6, EVENTOUT
VSS	H12	P	-	Default: VSS
VDD	J12	P	-	Default: VDD
PB12	P12	I/O	5VT	Default: PB12 Alternate: TIMER0_BRKIN, I2C1_SMBA, SPI1_NSS, I2S1_WS, SPI3_NSS, USART2_CK, CAN1_RX, USBHS_ULPI_D5, ENET_MII_TXD0, ENET_RMII_TXD0, USBHS_ID, EVENTOUT
PB13	P13	I/O	5VT	Default: PB13 Alternate: TIMER0_CH0_ON, SPI1_SCK, I2S1_CK, SPI3_SCK, USART2_CTS, CAN1_TX, USBHS_ULPI_D6, ENET_MII_TXD1, ENET_RMII_TXD1, EVENTOUT,

GD32F450xx BGA176				
Pin Name	Pins	Pin Type <sup>(1)</sup>	I/O Level <sup>(2)</sup>	Functions description
				I2C1_TXFRAME Additional: USBHS_VBUS
PB14	R14	I/O	5VT	Default: PB14 Alternate: TIMER0_CH1_ON, TIMER7_CH1_ON, SPI1_MISO, I2S1_ADD_SD, USART2_RTS, TIMER11_CH0, USBHS_DM, EVENTOUT
PB15	R15	I/O	5VT	Default: PB15 Alternate: RTC_REFIN, TIMER0_CH2_ON, TIMER7_CH2_ON, SPI1_MOSI, I2S1_SD, TIMER11_CH1, USBHS_DP, EVENTOUT
PD8	P15	I/O	5VT	Default: PD8 Alternate: USART2_TX, EXMC_D13, EVENTOUT
PD9	P14	I/O	5VT	Default: PD9 Alternate: USART2_RX, EXMC_D14, EVENTOUT
PD10	N15	I/O	5VT	Default: PD10 Alternate: USART2_CK, EXMC_D15, TLI_B3, EVENTOUT
PD11	N14	I/O	5VT	Default: PD11 Alternate: USART2_CTS, EXMC_A16/EXMC_CLE, EVENTOUT
PD12	N13	I/O	5VT	Default: PD12 Alternate: TIMER3_CH0, USART2_RTS, EXMC_A17/EXMC_ALE, EVENTOUT
PD13	M15	I/O	5VT	Default: PD13 Alternate: TIMER3_CH1, EXMC_A18, EVENTOUT
VDD	J13	P	-	Default: VDD
PD14	M14	I/O	5VT	Default: PD14 Alternate: TIMER3_CH2, EXMC_D0, EVENTOUT
PD15	L14	I/O	5VT	Default: PD15 Alternate: TIMER3_CH3, EXMC_D1, EVENTOUT, CTC_SYNC
PG2	L15	I/O	5VT	Default: PG2 Alternate: EXMC_A12, EVENTOUT
PG3	K15	I/O	5VT	Default: PG3 Alternate: EXMC_A13, EVENTOUT
PG4	K14	I/O	5VT	Default: PG4 Alternate: EXMC_A14, EVENTOUT
PG5	K13	I/O	5VT	Default: PG5 Alternate: EXMC_A15, EVENTOUT
PG6	J15	I/O	5VT	Default: PG6 Alternate: EXMC_INT1, DCI_D12, TLI_R7, EVENTOUT
PG7	J14	I/O	5VT	Default: PG7 Alternate: USART5_CK, EXMC_INT2, DCI_D13, TLI_PIXCLK, EVENTOUT
PG8	H14	I/O	5VT	Default: PG8

GD32F450xx BGA176				
Pin Name	Pins	Pin Type <sup>(1)</sup>	I/O Level <sup>(2)</sup>	Functions description
				Alternate: SPI5_NSS, USART5_RTS, ENET_PPS_OUT, EXMC_SDCLK, EVENTOUT
VSS	G12	P	-	Default: VSS
VDD	H13	P	-	Default: VDD
PC6	H15	I/O	5VT	Default: PC6 Alternate: TIMER2_CH0, TIMER7_CH0, I2S1_MCK, USART5_TX, SDIO_D6, DCI_D0, TLI_HSYNC, EVENTOUT
PC7	G15	I/O	5VT	Default: PC7 Alternate: TIMER2_CH1, TIMER7_CH1, SPI1_SCK, I2S1_CK, I2S2_MCK, USART5_RX, SDIO_D7, DCI_D1, TLI_G6, EVENTOUT
PC8	G14	I/O	5VT	Default: PC8 Alternate: TIMER2_CH2, TIMER7_CH2, USART5_CK, SDIO_D0, DCI_D2, EVENTOUT
PC9	F14	I/O	5VT	Default: PC9 Alternate: CK_OUT1, TIMER2_CH3, TIMER7_CH3, I2C2_SDA, I2S_CKIN, SDIO_D1, DCI_D3, EVENTOUT
PA8	F15	I/O	5VT	Default: PA8 Alternate: CK_OUT0, TIMER0_CH0, I2C2_SCL, USART0_CK, USBFS_SOF, SDIO_D1, TLI_R6, EVENTOUT, CTC_SYNC
PA9	E15	I/O	5VT	Default: PA9 Alternate: TIMER0_CH1, I2C2_SMBA, SPI1_SCK, I2S1_CK, USART0_TX, SDIO_D2, DCI_D0, EVENTOUT Additional: USBFS_VBUS
PA10	D15	I/O	5VT	Default: PA10 Alternate: TIMER0_CH2, SPI4_MOSI, USART0_RX, USBFS_ID, DCI_D1, EVENTOUT, I2C2_TXFRAME
PA11	C15	I/O	5VT	Default: PA11 Alternate: TIMER0_CH3, SPI3_MISO, USART0_CTS, USART5_TX, CAN0_RX, USBFS_DM, TLI_R4, EVENTOUT
PA12	B15	I/O	5VT	Default: PA12 Alternate: TIMER0_ETI, SPI4_MISO, USART0_RTS, USART5_RX, CAN0_TX, USBFS_DP, TLI_R5, EVENTOUT
PA13	A15	I/O	5VT	Default: JTMS, SWDIO, PA13 Alternate: EVENTOUT
NC	F13	-	-	-
VSS	F12	P	-	Default: VSS
VDD	G13	P	-	Default: VDD
PH13	E12	I/O	5VT	Default: PH13 Alternate: TIMER7_CH0_ON, CAN0_TX, EXMC_D21, TLI_G2, EVENTOUT
PH14	E13	I/O	5VT	Default: PH14 Alternate: TIMER7_CH1_ON, EXMC_D22, DCI_D4, TLI_G3,

GD32F450xx BGA176				
Pin Name	Pins	Pin Type <sup>(1)</sup>	I/O Level <sup>(2)</sup>	Functions description
				EVENTOUT
PH15	D13	I/O	5VT	Default: PH15 Alternate: TIMER7_CH2_ON, EXMC_D23, DCI_D11, TLI_G4, EVENTOUT
PI0	E14	I/O	5VT	Default: PI0 Alternate: TIMER4_CH3, SPI1_NSS, I2S1_WS, EXMC_D24, DCI_D13, TLI_G5, EVENTOUT
PI1	D14	I/O	5VT	Default: PI1 Alternate: SPI1_SCK, I2S1_CK, EXMC_D25, DCI_D8, TLI_G6, EVENTOUT
PI2	C14	I/O	5VT	Default: PI2 Alternate: TIMER7_CH3, SPI1_MISO, I2S1_ADD_SD, EXMC_D26, DCI_D9, TLI_G7, EVENTOUT
PI3	C13	I/O	5VT	Default: PI3 Alternate: TIMER7_ETI, SPI1_MOSI, I2S1_SD, EXMC_D27, DCI_D10, EVENTOUT
VSS	D9	P	-	Default: VSS
VDD	C9	P	-	Default: VDD
PA14	A14	I/O	5VT	Default: JTCK, SWCLK, PA14 Alternate: EVENTOUT
PA15	A13	I/O	5VT	Default: JTDI, PA15 Alternate: TIMER1_CH0, TIMER1_ETI, SPI0_NSS, SPI2_NSS, I2S2_WS, USART0_TX, EVENTOUT
PC10	B14	I/O	5VT	Default: PC10 Alternate: SPI2_SCK, I2S2_CK, USART2_TX, UART3_TX, SDIO_D2, DCI_D8, TLI_R2, EVENTOUT
PC11	B13	I/O	5VT	Default: PC11 Alternate: I2S2_ADD_SD, SPI2_MISO, USART2_RX, UART3_RX, SDIO_D3, DCI_D4, EVENTOUT
PC12	A12	I/O	5VT	Default: PC12 Alternate: I2C1_SDA, SPI2_MOSI, I2S2_SD, USART2_CK, UART4_TX, SDIO_CK, DCI_D9, EVENTOUT
PD0	B12	I/O	5VT	Default: PD0 Alternate: SPI3_MISO, SPI2_MOSI, I2S2_SD, CAN0_RX, EXMC_D2, EVENTOUT
PD1	C12	I/O	5VT	Default: PD1 Alternate: SPI1_NSS, I2S1_WS, CAN0_TX, EXMC_D3, EVENTOUT
PD2	D12	I/O	5VT	Default: PD2 Alternate: TIMER2_ETI, UART4_RX, SDIO_CMD, DCI_D11, EVENTOUT
PD3	D11	I/O	5VT	Default: PD3 Alternate: SPI1_SCK, I2S1_CK, USART1_CTS, EXMC_CLK, DCI_D5, TLI_G7, EVENTOUT

GD32F450xx BGA176				
Pin Name	Pins	Pin Type <sup>(1)</sup>	I/O Level <sup>(2)</sup>	Functions description
PD4	D10	I/O	5VT	Default: PD4 Alternate: USART1_RTS, EXMC_NOE, EVENTOUT
PD5	C11	I/O	5VT	Default: PD5 Alternate: USART1_TX, EXMC_NWE, EVENTOUT
VSS	D8	P	-	Default: VSS
VDD	C8	P	-	Default: VDD
PD6	B11	I/O	5VT	Default: PD6 Alternate: SPI2_MOSI, I2S2_SD, USART1_RX, EXMC_NWAIT, DCI_D10, TLI_B2, EVENTOUT
PD7	A11	I/O	5VT	Default: PD7 Alternate: USART1_CK, EXMC_NE0/EXMC_NCE1, EVENTOUT
PG9	C10	I/O	5VT	Default: PG9 Alternate: USART5_RX, EXMC_NE1, EXMC_NCE2, DCI_VSYNC, EVENTOUT
PG10	B10	I/O	5VT	Default: PG10 Alternate: SPI5_IO2, TLI_G3, EXMC_NCE3_0, EXMC_NE2, DCI_D2, TLI_B2, EVENTOUT
PG11	B9	I/O	5VT	Default: PG11 Alternate: SPI5_IO3, SPI3_SCK, ENET_MII_TX_EN, ETH_RMII_TX_EN, EXMC_NCE3_1, DCI_D3, TLI_B3, EVENTOUT
PG12	B8	I/O	5VT	Default: PG12 Alternate: SPI5_MISO, SPI3_MISO, USART5_RTS, TLI_B4, EXMC_NE3, TLI_B1, EVENTOUT
PG13	A8	I/O	5VT	Default: PG13 Alternate: SPI5_SCK, SPI3_MOSI, USART5_CTS, ENET_MII_TXD0, ENET_RMII_TXD0, EXMC_A24, EVENTOUT
PG14	A7	I/O	5VT	Default: PG14 Alternate: SPI5_MOSI, SPI3_NSS, USART5_TX, ENET_MII_TXD1, ENET_RMII_TXD1, EXMC_A25, EVENTOUT
VSS	D7	P	-	Default: VSS
VDD	C7	P	-	Default: VDD
PG15	B7	I/O	5VT	Default: PG15 Alternate: USART5_CTS, EXMC_SDNCAS, DCI_D13, EVENTOUT
PB3	A10	I/O	5VT	Default: JTDO, PB3 Alternate: TRACESWO, TIMER1_CH1, SPI0_SCK, SPI2_SCK, I2S2_CK, USART0_RX, I2C1_SDA, EVENTOUT
PB4	A9	I/O	5VT	Default: JNTRST, PB4 Alternate: TIMER2_CH0, SPI0_MISO, SPI2_MISO, I2S2_ADD_SD, I2C2_SDA, SDIO_D0, EVENTOUT,

GD32F450xx BGA176				
Pin Name	Pins	Pin Type <sup>(1)</sup>	I/O Level <sup>(2)</sup>	Functions description
				I2C0_TXFRAME
PB5	A6	I/O	5VT	Default: PB5 Alternate: TIMER2_CH1, I2C0_SMBA, SPI0_MOSI, SPI2_MOSI, I2S2_SD, CAN1_RX, USBHS_ULPI_D7, ENET_PPS_OUT, EXMC_SDCKE1, DCI_D10, EVENTOUT
PB6	B6	I/O	5VT	Default: PB6 Alternate: TIMER3_CH0, I2C0_SCL, USART0_TX, CAN1_TX, EXMC_SDNE1, DCI_D5, EVENTOUT
PB7	B5	I/O	5VT	Default: PB7 Alternate: TIMER3_CH1, I2C0_SDA, USART0_RX, EXMC_NL/EXMC_NADV, DCI_VSYNC, EVENTOUT
BOOT0	D6	I/O	5VT	Default: BOOT0
PB8	A5	I/O	5VT	Default: PB8 Alternate: TIMER1_CH0, TIMER1_ETI, TIMER3_CH2, TIMER9_CH0, I2C0_SCL, SPI4_MOSI, CAN0_RX, ENET_MII_TXD3, SDIO_D4, DCI_D6, TLI_B6, EVENTOUT
PB9	B4	I/O	5VT	Default: PB9 Alternate: TIMER1_CH1, TIMER3_CH3, TIMER10_CH0, I2C0_SDA, SPI1_NSS, I2S1_WS, CAN0_TX, SDIO_D5, DCI_D7, TLI_B7, EVENTOUT
PE0	A4	I/O	5VT	Default: PE0 Alternate: TIMER3_ETI, UART7_RX, EXMC_NBL0, DCI_D2, EVENTOUT
PE1	A3	I/O	5VT	Default: PE1 Alternate: TIMER0_CH1_ON, UART7_TX, EXMC_NBL1, DCI_D3, EVENTOUT
VSS	D5	P	-	Default: VSS
PDR_ON	C6	P	-	Default: PDR_ON
VDD	C5	P	-	Default: VDD
PI4	D4	I/O	5VT	Default: PI4 Alternate: TIMER7_BRKIN, EXMC_NBL2, DCI_D5, TLI_B4, EVENTOUT
PI5	C4	I/O	5VT	Default: PI5 Alternate: TIMER7_CH0, EXMC_NBL3, DCI_VSYNC, TLI_B5, EVENTOUT
PI6	C3	I/O	5VT	Default: PI6 Alternate: TIMER7_CH1, EXMC_D28, DCI_D6, TLI_B6, EVENTOUT
PI7	C2	I/O	5VT	Default: PI7 Alternate: TIMER7_CH2, EXMC_D29, DCI_D7, TLI_B7, EVENTOUT

**Notes:**

(1) Type: I = input, O = output, P = power.

(2) I/O Level: 5VT = 5 V tolerant.

## 2.6.2. GD32F450Zx LQFP144 pin definitions

**Table 2-4. GD32F450Zx LQFP144 pin definitions**

GD32F450Zx LQFP144				
Pin Name	Pins	Pin Type <sup>(1)</sup>	I/O Level <sup>(2)</sup>	Functions description
PE2	1	I/O	5VT	Default: PE2 Alternate: SPI3_SCK, ENET_MII_TXD3, EXMC_A23, EVENTOUT
PE3	2	I/O	5VT	Default: PE3 Alternate: EXMC_A19, EVENTOUT
PE4	3	I/O	5VT	Default: PE4 Alternate: SPI3_NSS, EXMC_A20, DCI_D4, TLI_B0, EVENTOUT
PE5	4	I/O	5VT	Default: PE5 Alternate: TIMER8_CH0, SPI3_MISO, EXMC_A21, DCI_D6, TLI_G0, EVENTOUT
PE6	5	I/O	5VT	Default: PE6 Alternate: TIMER8_CH1, SPI3_MOSI, EXMC_A22, DCI_D7, TLI_G1, EVENTOUT
VBAT	6	P	-	Default: VBAT
PC13-TAMPER-RTC	7	I/O	5VT	Default: PC13 Alternate: EVENTOUT Additional: RTC_TAMP0, RTC_OUT, RTC_TS
PC14-OSC32IN	8	I/O	5VT	Default: PC14 Alternate: EVENTOUT Additional: OSC32IN
PC15-OSC32OUT	9	I/O	5VT	Default: PC15 Alternate: EVENTOUT Additional: OSC32OUT
PF0	10	I/O	5VT	Default: PF0 Alternate: I2C1_SDA, EXMC_A0, EVENTOUT, CTC_SYNC
PF1	11	I/O	5VT	Default: PF1 Alternate: I2C1_SCL, EXMC_A1, EVENTOUT
PF2	12	I/O	5VT	Default: PF2 Alternate: I2C1_SMBA, EXMC_A2, EVENTOUT
PF3	13	I/O	5VT	Default: PF3 Alternate: EXMC_A3, EVENTOUT, I2C1_TXFRAME Additional: ADC2_IN9
PF4	14	I/O	5VT	Default: PF4 Alternate: EXMC_A4, EVENTOUT Additional: ADC2_IN14
PF5	15	I/O	5VT	Default: PF5 Alternate: EXMC_A5, EVENTOUT Additional: ADC2_IN15
VSS	16	P	-	Default: VSS

GD32F450Zx LQFP144				
Pin Name	Pins	Pin Type <sup>(1)</sup>	I/O Level <sup>(2)</sup>	Functions description
VDD	17	P	-	Default: VDD
PF6	18	I/O	5VT	Default: PF6 Alternate: TIMER9_CH0, SPI4_NSS, UART6_RX, EXMC_NIORD, EVENTOUT Additional: ADC2_IN4
PF7	19	I/O	5VT	Default: PF7 Alternate: TIMER10_CH0, SPI4_SCK, UART6_TX, EXMC_NREG, EVENTOUT Additional: ADC2_IN5
PF8	20	I/O	5VT	Default: PF8 Alternate: SPI4_MISO, TIMER12_CH0, EXMC_NIOWR, EVENTOUT Additional: ADC2_IN6
PF9	21	I/O	5VT	Default: PF9 Alternate: SPI4_MOSI, TIMER13_CH0, EXMC_CD, EVENTOUT Additional: ADC2_IN7
PF10	22	I/O	5VT	Default: PF10 Alternate: EXMC_INTR, DCI_D11, TLI_DE, EVENTOUT Additional: ADC2_IN8
PH0/OSCIN	23	I/O	5VT	Default: PH0, OSCIN Alternate: EVENTOUT Additional: OSCIN
PH1/OSCO UT	24	I/O	5VT	Default: PH1, OSCOUT Alternate: EVENTOUT Additional: OSCOUT
NRST	25	-	-	Default: NRST
PC0	26	I/O	5VT	Default: PC0 Alternate: USBHS_ULPI_STP, EXMC_SDNWE, EVENTOUT Additional: ADC012_IN10
PC1	27	I/O	5VT	Default: PC1 Alternate: SPI2_MOSI, I2S2_SD, SPI1_MOSI, I2S1_SD, ENET_MDC, EVENTOUT Additional: ADC012_IN11
PC2	28	I/O	5VT	Default: PC2 Alternate: SPI1_MISO, I2S1_ADD_SD, USBHS_ULPI_DIR, ENET_MII_TXD2, EXMC_SDNE0, EVENTOUT Additional: ADC012_IN12
PC3	29	I/O	5VT	Default: PC3 Alternate: SPI1_MOSI, I2S1_SD, USBHS_ULPI_NXT, ENET_MII_TX_CLK, EXMC_SDCKE0, EVENTOUT Additional: ADC012_IN13
VDD	30	P	-	Default: VDD

GD32F450Zx LQFP144				
Pin Name	Pins	Pin Type <sup>(1)</sup>	I/O Level <sup>(2)</sup>	Functions description
VSSA	31	P	-	Default: VSSA
VREFP	32	P	-	Default: VREFP
V <sub>DDA</sub>	33	P	-	Default: V <sub>DDA</sub>
PA0-WKUP	34	I/O	5VT	Default: PA0 Alternate: TIMER1_CH0, TIMER1_ETI, TIMER4_CH0, TIMER7_ETI, USART1_CTS, UART3_TX, ENET_MII_CRS, EVENTOUT Additional: ADC012_IN0, WKUP
PA1	35	I/O	5VT	Default: PA1 Alternate: TIMER1_CH1, TIMER4_CH1, SPI3_MOSI, USART1_RTS, UART3_RX, ENET_MII_RX_CLK, ENET_RMII_REF_CLK, EVENTOUT Additional: ADC012_IN1
PA2	36	I/O	5VT	Default: PA2 Alternate: TIMER1_CH2, TIMER4_CH2, TIMER8_CH0, I2S_CKIN, USART1_TX, ENET_MDIO, EVENTOUT Additional: ADC012_IN2
PA3	37	I/O	5VT	Default: PA3 Alternate: TIMER1_CH3, TIMER4_CH3, TIMER8_CH1, I2S1_MCK, USART1_RX, USBHS_ULPI_D0, ENET_MII_COL, TLI_B5, EVENTOUT Additional: ADC012_IN3
VSS	38	P	-	Default: VSS
VDD	39	P	-	Default: VDD
PA4	40	I/O		Default: PA4 Alternate: SPI0_NSS, SPI2_NSS, I2S2_WS, USART1_CK, USBHS_SOF, DCI_HSYNC, TLI_VSYNC, EVENTOUT Additional: ADC01_IN4, DAC0_OUT0
PA5	41	I/O		Default: PA5 Alternate: TIMER1_CH0, TIMER1_ETI, TIMER7_CH0_ON, SPI0_SCK, USBHS_ULPI_CK, EVENTOUT Additional: ADC01_IN5, DAC0_OUT1
PA6	42	I/O	5VT	Default: PA6 Alternate: TIMER0_BRKIN, TIMER2_CH0, TIMER7_BRKIN, SPI0_MISO, I2S1_MCK, TIMER12_CH0, SDIO_CMD, DCI_PIXCLK, TLI_G2, EVENTOUT Additional: ADC01_IN6
PA7	43	I/O	5VT	Default: PA7 Alternate: TIMER0_CH0_ON, TIMER2_CH1, TIMER7_CH0_ON, SPI0_MOSI, TIMER13_CH0, ENET_MII_RX_DV, ENET_RMII_CRS_DV, EXMC_SDNWE, EVENTOUT Additional: ADC01_IN7
PC4	44	I/O	5VT	Default: PC4

GD32F450Zx LQFP144				
Pin Name	Pins	Pin Type <sup>(1)</sup>	I/O Level <sup>(2)</sup>	Functions description
				Alternate: ENET_MII_RXD0, ENET_RMII_RXD0, EXMC_SDNE0, EVENTOUT Additional: ADC01_IN14
PC5	45	I/O	5VT	Default: PC5 Alternate: USART2_RX, ENET_MII_RXD1, ENET_RMII_RXD1, EXMC_SDCKE0, EVENTOUT Additional: ADC01_IN15
PB0	46	I/O	5VT	Default: PB0 Alternate: TIMER0_CH1_ON, TIMER2_CH2, TIMER7_CH1_ON, SPI4_SCK, SPI2_MOSI, I2S2_SD, TLI_R3, USBHS_ULPI_D1, ENET_MII_RXD2, SDIO_D1, EVENTOUT Additional: ADC01_IN8, IREF
PB1	47	I/O	5VT	Default: PB1 Alternate: TIMER0_CH2_ON, TIMER2_CH3, TIMER7_CH2_ON, SPI4_NSS, TLI_R6, USBHS_ULPI_D2, ENET_MII_RXD3, SDIO_D2, EVENTOUT Additional: ADC01_IN9
PB2	48	I/O	5VT	Default: PB2, BOOT1 Alternate: TIMER1_CH3, SPI2_MOSI, I2S2_SD, USBHS_ULPI_D4, SDIO_CK, EVENTOUT
PF11	49	I/O	5VT	Default: PF11 Alternate: SPI4_MOSI, EXMC_SDNRAS, DCI_D12, EVENTOUT
PF12	50	I/O	5VT	Default: PF12 Alternate: EXMC_A6, EVENTOUT
VSS	51	P	-	Default: VSS
VDD	52	P	-	Default: VDD
PF13	53	I/O	5VT	Default: PF13 Alternate: EXMC_A7, EVENTOUT
PF14	54	I/O	5VT	Default: PF14 Alternate: EXMC_A8, EVENTOUT
PF15	55	I/O	5VT	Default: PF15 Alternate: EXMC_A9, EVENTOUT
PG0	56	I/O	5VT	Default: PG0 Alternate: EXMC_A10, EVENTOUT
PG1	57	I/O	5VT	Default: PG1 Alternate: EXMC_A11, EVENTOUT
PE7	58	I/O	5VT	Default: PE7 Alternate: TIMER0_ETI, UART6_RX, EXMC_D4, EVENTOUT
PE8	59	I/O	5VT	Default: PE8 Alternate: TIMER0_CH0_ON, UART6_TX, EXMC_D5, EVENTOUT

GD32F450Zx LQFP144				
Pin Name	Pins	Pin Type <sup>(1)</sup>	I/O Level <sup>(2)</sup>	Functions description
PE9	60	I/O	5VT	Default: PE9 Alternate: TIMER0_CH0, EXMC_D6, EVENTOUT
VSS	61	P	-	Default: VSS
VDD	62	P	-	Default: VDD
PE10	63	I/O	5VT	Default: PE10 Alternate: TIMER0_CH1_ON, EXMC_D7, EVENTOUT
PE11	64	I/O	5VT	Default: PE11 Alternate: TIMER0_CH1, SPI3_NSS, SPI4_NSS, EXMC_D8, TLI_G3, EVENTOUT
PE12	65	I/O	5VT	Default: PE12 Alternate: TIMER0_CH2_ON, SPI3_SCK, SPI4_SCK, EXMC_D9, TLI_B4, EVENTOUT
PE13	66	I/O	5VT	Default: PE13 Alternate: TIMER0_CH2, SPI3_MISO, SPI4_MISO, EXMC_D10, TLI_DE, EVENTOUT
PE14	67	I/O	5VT	Default: PE14 Alternate: TIMER0_CH3, SPI3_MOSI, SPI4_MOSI, EXMC_D11, TLI_PIXCLK, EVENTOUT
PE15	68	I/O	5VT	Default: PE15 Alternate: TIMER0_BRKIN, EXMC_D12, TLI_R7, EVENTOUT
PB10	69	I/O	5VT	Default: PB10 Alternate: TIMER1_CH2, I2C1_SCL, SPI1_SCK, I2S1_CK, I2S2_MCK, USART2_TX, USBHS_ULPI_D3, ENET_MII_RX_ER, SDIO_D7, TLI_G4, EVENTOUT
PB11	70	I/O	5VT	Default: PB11 Alternate: TIMER1_CH3, I2C1_SDA, I2S_CKIN, USART2_RX, USBHS_ULPI_D4, ENET_MII_TX_EN, ENET_RMII_TX_EN, TLI_G5, EVENTOUT
NC	71	-	-	-
VDD	72	P	-	Default: VDD
PB12	73	I/O	5VT	Default: PB12 Alternate: TIMER0_BRKIN, I2C1_SMBA, SPI1_NSS, I2S1_WS, SPI3_NSS, USART2_CK, CAN1_RX, USBHS_ULPI_D5, ENET_MII_TXD0, ENET_RMII_TXD0, USBHS_ID, EVENTOUT
PB13	74	I/O	5VT	Default: PB13 Alternate: TIMER0_CH0_ON, SPI1_SCK, I2S1_CK, SPI3_SCK, USART2_CTS, CAN1_TX, USBHS_ULPI_D6, ENET_MII_TXD1, ENET_RMII_TXD1, EVENTOUT, I2C1_TXFRAME Additional: USBHS_VBUS
PB14	75	I/O	5VT	Default: PB14 Alternate: TIMER0_CH1_ON, TIMER7_CH1_ON,

GD32F450Zx LQFP144				
Pin Name	Pins	Pin Type <sup>(1)</sup>	I/O Level <sup>(2)</sup>	Functions description
				SPI1_MISO, I2S1_ADD_SD, USART2_RTS, TIMER11_CH0, USBHS_DM, EVENTOUT
PB15	76	I/O	5VT	Default: PB15 Alternate: RTC_REFIN, TIMER0_CH2_ON, TIMER7_CH2_ON, SPI1_MOSI, I2S1_SD, TIMER11_CH1, USBHS_DP, EVENTOUT
PD8	77	I/O	5VT	Default: PD8 Alternate: USART2_TX, EXMC_D13, EVENTOUT
PD9	78	I/O	5VT	Default: PD9 Alternate: USART2_RX, EXMC_D14, EVENTOUT
PD10	79	I/O	5VT	Default: PD10 Alternate: USART2_CK, EXMC_D15, TLI_B3, EVENTOUT
PD11	80	I/O	5VT	Default: PD11 Alternate: USART2_CTS, EXMC_A16/EXMC_CLE, EVENTOUT
PD12	81	I/O	5VT	Default: PD12 Alternate: TIMER3_CH0, USART2_RTS, EXMC_A17/EXMC_ALE, EVENTOUT
PD13	82	I/O	5VT	Default: PD13 Alternate: TIMER3_CH1, EXMC_A18, EVENTOUT
VSS	83	P	-	Default: VSS
VDD	84	P	-	Default: VDD
PD14	85	I/O	5VT	Default: PD14 Alternate: TIMER3_CH2, EXMC_D0, EVENTOUT
PD15	86	I/O	5VT	Default: PD15 Alternate: TIMER3_CH3, EXMC_D1, EVENTOUT, CTC_SYNC
PG2	87	I/O	5VT	Default: PG2 Alternate: EXMC_A12, EVENTOUT
PG3	88	I/O	5VT	Default: PG3 Alternate: EXMC_A13, EVENTOUT
PG4	89	I/O	5VT	Default: PG4 Alternate: EXMC_A14, EVENTOUT
PG5	90	I/O	5VT	Default: PG5 Alternate: EXMC_A15, EVENTOUT
PG6	91	I/O	5VT	Default: PG6 Alternate: EXMC_INT1, DCI_D12, TLI_R7, EVENTOUT
PG7	92	I/O	5VT	Default: PG7 Alternate: USART5_CK, EXMC_INT2, DCI_D13, TLI_PIXCLK, EVENTOUT
PG8	93	I/O	5VT	Default: PG8 Alternate: SPI5_NSS, USART5_RTS, ENET_PPS_OUT, EXMC_SDCLK, EVENTOUT
VSS	94	P	-	Default: VSS

GD32F450Zx LQFP144				
Pin Name	Pins	Pin Type <sup>(1)</sup>	I/O Level <sup>(2)</sup>	Functions description
VDD	95	P	-	Default: VDD
PC6	96	I/O	5VT	Default: PC6 Alternate: TIMER2_CH0, TIMER7_CH0, I2S1_MCK, USART5_TX, SDIO_D6, DCI_D0, TLI_HSYNC, EVENTOUT
PC7	97	I/O	5VT	Default: PC7 Alternate: TIMER2_CH1, TIMER7_CH1, SPI1_SCK, I2S1_CK, I2S2_MCK, USART5_RX, SDIO_D7, DCI_D1, TLI_G6, EVENTOUT
PC8	98	I/O	5VT	Default: PC8 Alternate: TIMER2_CH2, TIMER7_CH2, USART5_CK, SDIO_D0, DCI_D2, EVENTOUT
PC9	99	I/O	5VT	Default: PC9 Alternate: CK_OUT1, TIMER2_CH3, TIMER7_CH3, I2C2_SDA, I2S_CKIN, SDIO_D1, DCI_D3, EVENTOUT
PA8	100	I/O	5VT	Default: PA8 Alternate: CK_OUT0, TIMER0_CH0, I2C2_SCL, USART0_CK, USBFS_SOF, SDIO_D1, TLI_R6, EVENTOUT, CTC_SYNC
PA9	101	I/O	5VT	Default: PA9 Alternate: TIMER0_CH1, I2C2_SMBA, SPI1_SCK, I2S1_CK, USART0_TX, SDIO_D2, DCI_D0, EVENTOUT Additional: USBFS_VBUS
PA10	102	I/O	5VT	Default: PA10 Alternate: TIMER0_CH2, SPI4_MOSI, USART0_RX, USBFS_ID, DCI_D1, EVENTOUT, I2C2_TXFRAME
PA11	103	I/O	5VT	Default: PA11 Alternate: TIMER0_CH3, SPI3_MISO, USART0_CTS, USART5_TX, CAN0_RX, USBFS_DM, TLI_R4, EVENTOUT
PA12	104	I/O	5VT	Default: PA12 Alternate: TIMER0_ETI, SPI4_MISO, USART0_RTS, USART5_RX, CAN0_TX, USBFS_DP, TLI_R5, EVENTOUT
PA13	105	I/O	5VT	Default: JTMS, SWDIO, PA13 Alternate: EVENTOUT
NC	106	-	-	-
VSS	107	P	-	Default: VSS
VDD	108	P	-	Default: VDD
PA14	109	I/O	5VT	Default: JTCK, SWCLK, PA14 Alternate: EVENTOUT
PA15	110	I/O	5VT	Default: JTDI, PA15 Alternate: TIMER1_CH0, TIMER1_ETI, SPI0_NSS, SPI2_NSS, I2S2_WS, USART0_TX, EVENTOUT

GD32F450Zx LQFP144				
Pin Name	Pins	Pin Type <sup>(1)</sup>	I/O Level <sup>(2)</sup>	Functions description
PC10	111	I/O	5VT	Default: PC10 Alternate: SPI2_SCK, I2S2_CK, USART2_TX, UART3_TX, SDIO_D2, DCI_D8, TLI_R2, EVENTOUT
PC11	112	I/O	5VT	Default: PC11 Alternate: I2S2_ADD_SD, SPI2_MISO, USART2_RX, UART3_RX, SDIO_D3, DCI_D4, EVENTOUT
PC12	113	I/O	5VT	Default: PC12 Alternate: I2C1_SDA, SPI2_MOSI, I2S2_SD, USART2_CK, UART4_TX, SDIO_CK, DCI_D9, EVENTOUT
PD0	114	I/O	5VT	Default: PD0 Alternate: SPI3_MISO, SPI2_MOSI, I2S2_SD, CAN0_RX, EXMC_D2, EVENTOUT
PD1	115	I/O	5VT	Default: PD1 Alternate: SPI1_NSS, I2S1_WS, CAN0_TX, EXMC_D3, EVENTOUT
PD2	116	I/O	5VT	Default: PD2 Alternate: TIMER2_ETI, UART4_RX, SDIO_CMD, DCI_D11, EVENTOUT
PD3	117	I/O	5VT	Default: PD3 Alternate: SPI1_SCK, I2S1_CK, USART1_CTS, EXMC_CLK, DCI_D5, TLI_G7, EVENTOUT
PD4	118	I/O	5VT	Default: PD4 Alternate: USART1_RTS, EXMC_NOE, EVENTOUT
PD5	119	I/O	5VT	Default: PD5 Alternate: USART1_TX, EXMC_NWE, EVENTOUT
VSS	120	P	-	Default: VSS
VDD	121	P	-	Default: VDD
PD6	122	I/O	5VT	Default: PD6 Alternate: SPI2_MOSI, I2S2_SD, USART1_RX, EXMC_NWAIT, DCI_D10, TLI_B2, EVENTOUT
PD7	123	I/O	5VT	Default: PD7 Alternate: USART1_CK, EXMC_NE0/EXMC_NCE1, EVENTOUT
PG9	124	I/O	5VT	Default: PG9 Alternate: USART5_RX, EXMC_NE1, EXMC_NCE2, DCI_VSYNC, EVENTOUT
PG10	125	I/O	5VT	Default: PG10 Alternate: SPI5_IO2, TLI_G3, EXMC_NCE3_0, EXMC_NE2, DCI_D2, TLI_B2, EVENTOUT
PG11	126	I/O	5VT	Default: PG11 Alternate: SPI5_IO3, SPI3_SCK, ENET_MII_TX_EN, ENET_RMII_TX_EN, EXMC_NCE3_1, DCI_D3, TLI_B3, EVENTOUT
PG12	127	I/O	5VT	Default: PG12

GD32F450Zx LQFP144				
Pin Name	Pins	Pin Type <sup>(1)</sup>	I/O Level <sup>(2)</sup>	Functions description
				Alternate: SPI5_MISO, SPI3_MISO, USART5_RTS, TLI_B4, EXMC_NE3, TLI_B1, EVENTOUT
PG13	128	I/O	5VT	Default: PG13 Alternate: SPI5_SCK, SPI3_MOSI, USART5_CTS, ENET_MII_TXD0, ENET_RMII_TXD0, EXMC_A24, EVENTOUT
PG14	129	I/O	5VT	Default: PG14 Alternate: SPI5_MOSI, SPI3_NSS, USART5_TX, ENET_MII_TXD1, ENET_RMII_TXD1, EXMC_A25, EVENTOUT
VSS	130	P	-	Default: VSS
VDD	131	P	-	Default: VDD
PG15	132	I/O	5VT	Default: PG15 Alternate: USART5_CTS, EXMC_SDNCAS, DCI_D13, EVENTOUT
PB3	133	I/O	5VT	Default: JTDO, PB3 Alternate: TRACESWO, TIMER1_CH1, SPI0_SCK, SPI2_SCK, I2S2_CK, USART0_RX, I2C1_SDA, EVENTOUT
PB4	134	I/O	5VT	Default: NJTRST, PB4 Alternate: TIMER2_CH0, SPI0_MISO, SPI2_MISO, I2S2_ADD_SD, I2C2_SDA, SDIO_D0, EVENTOUT, I2C0_TXFRAME
PB5	135	I/O	5VT	Default: PB5 Alternate: TIMER2_CH1, I2C0_SMBA, SPI0_MOSI, SPI2_MOSI, I2S2_SD, CAN1_RX, USBHS_ULPI_D7, ENET_PPS_OUT, EXMC_SDCKE1, DCI_D10, EVENTOUT
PB6	136	I/O	5VT	Default: PB6 Alternate: TIMER3_CH0, I2C0_SCL, USART0_TX, CAN1_TX, EXMC_SDNE1, DCI_D5, EVENTOUT
PB7	137	I/O	5VT	Default: PB7 Alternate: TIMER3_CH1, I2C0_SDA, USART0_RX, EXMC_NL/EXMC_NADV, DCI_VSYNC, EVENTOUT
BOOT0	138	I/O	5VT	Default: BOOT0
PB8	139	I/O	5VT	Default: PB8 Alternate: TIMER1_CH0, TIMER1_ETI, TIMER3_CH2, TIMER9_CH0, I2C0_SCL, SPI4_MOSI, CAN0_RX, ENET_MII_TXD3, SDIO_D4, DCI_D6, TLI_B6, EVENTOUT
PB9	140	I/O	5VT	Default: PB9 Alternate: TIMER1_CH1, TIMER3_CH3, TIMER10_CH0, I2C0_SDA, SPI1_NSS, I2S1_WS, CAN0_TX, SDIO_D5, DCI_D7, TLI_B7, EVENTOUT
PE0	141	I/O	5VT	Default: PE0 Alternate: TIMER3_ETI, UART7_RX, EXMC_NBL0,

GD32F450Zx LQFP144				
Pin Name	Pins	Pin Type <sup>(1)</sup>	I/O Level <sup>(2)</sup>	Functions description
				DCI_D2, EVENTOUT
PE1	142	I/O	5VT	Default: PE1 Alternate: TIMER0_CH1_ON, UART7_TX, EXMC_NBL1, DCI_D3, EVENTOUT
PDR_ON	143	P	-	Default: PDR_ON
VDD	144	P	-	Default: VDD

**Notes:**

(1) Type: I = input, O = output, P = power.

(2) I/O Level: 5VT = 5 V tolerant.

### 2.6.3. GD32F450Vx LQFP100 pin definitions

**Table 2-5. GD32F450Vx LQFP100 pin definitions**

GD32F450Vx LQFP100				
Pin Name	Pins	Pin Type <sup>(1)</sup>	I/O Level <sup>(2)</sup>	Functions description
PE2	1	I/O	5VT	Default: PE2 Alternate: SPI3_SCK, ENET_MII_TXD3, EXMC_A23, EVENTOUT
PE3	2	I/O	5VT	Default: PE3 Alternate: EXMC_A19, EVENTOUT
PE4	3	I/O	5VT	Default: PE4 Alternate: SPI3_NSS, EXMC_A20, DCI_D4, TLI_B0, EVENTOUT
PE5	4	I/O	5VT	Default: PE5 Alternate: TIMER8_CH0, SPI3_MISO, EXMC_A21, DCI_D6, TLI_G0, EVENTOUT
PE6	5	I/O	5VT	Default: PE6 Alternate: TIMER8_CH1, SPI3_MOSI, EXMC_A22, DCI_D7, TLI_G1, EVENTOUT
VBAT	6	P	-	Default: VBAT
PC13-TAMPER-RTC	7	I/O	5VT	Default: PC13 Alternate: EVENTOUT Additional: RTC_TAMP0, RTC_OUT, RTC_TS
PC14-OSC32IN	8	I/O	5VT	Default: PC14 Alternate: EVENTOUT Additional: OSC32IN
PC15-OSC32OUT	9	I/O	5VT	Default: PC15 Alternate: EVENTOUT Additional: OSC32OUT
VSS	10	P	-	Default: VSS
VDD	11	P	-	Default: VDD

GD32F450Vx LQFP100				
Pin Name	Pins	Pin Type <sup>(1)</sup>	I/O Level <sup>(2)</sup>	Functions description
PH0/OSCIN	12	I/O	5VT	Default: PH0, OSCIN Alternate: EVENTOUT Additional: OSCIN
PH1/OSCOU	13	I/O	5VT	Default: PH1, OSCOUT Alternate: EVENTOUT Additional: OSCOUT
NRST	14	-	-	Default: NRST
PC0	15	I/O	5VT	Default: PC0 Alternate: USBHS_ULPI_STP, EVENTOUT Additional: ADC012_IN10
PC1	16	I/O	5VT	Default: PC1 Alternate: SPI2_MOSI, I2S2_SD, SPI1_MOSI, I2S1_SD, ENET_MDC, EVENTOUT Additional: ADC012_IN11
PC2	17	I/O	5VT	Default: PC2 Alternate: SPI1_MISO, I2S1_ADD_SD, USBHS_ULPI_DIR, ENET_MII_TXD2, EVENTOUT Additional: ADC012_IN12
PC3	18	I/O	5VT	Default: PC3 Alternate: SPI1_MOSI, I2S1_SD, USBHS_ULPI_NXT, ENET_MII_TX_CLK, EVENTOUT Additional: ADC012_IN13
VDD	19	P	-	Default: VDD
VSSA	20	P	-	Default: VSSA
VREFP	21	P	-	Default: VREFP
V <sub>DDA</sub>	22	P	-	Default: V <sub>DDA</sub>
PA0-WKUP	23	I/O	5VT	Default: PA0 Alternate: TIMER1_CH0, TIMER1_ETI, TIMER4_CH0, TIMER7_ETI, USART1_CTS, UART3_TX, ENET_MII_CRS, EVENTOUT Additional: ADC012_IN0, WKUP
PA1	24	I/O	5VT	Default: PA1 Alternate: TIMER1_CH1, TIMER4_CH1, SPI3_MOSI, USART1_RTS, UART3_RX, ENET_MII_RX_CLK, ENET_RMII_REF_CLK, EVENTOUT Additional: ADC012_IN1
PA2	25	I/O	5VT	Default: PA2 Alternate: TIMER1_CH2, TIMER4_CH2, TIMER8_CH0, I2S_CKIN, USART1_TX, ENET_MDIO, EVENTOUT Additional: ADC012_IN2
PA3	26	I/O	5VT	Default: PA3 Alternate: TIMER1_CH3, TIMER4_CH3, TIMER8_CH1, I2S1_MCK, USART1_RX, USBHS_ULPI_D0,

GD32F450Vx LQFP100				
Pin Name	Pins	Pin Type <sup>(1)</sup>	I/O Level <sup>(2)</sup>	Functions description
				ENET_MII_COL, TLI_B5, EVENTOUT Additional: ADC012_IN3
VSS	27	P	-	Default: VSS
VDD	28	P	-	Default: VDD
PA4	29	I/O		Default: PA4 Alternate: SPI0_NSS, SPI2_NSS, I2S2_WS, USART1_CK, USBHS_SOF, DCI_HSYNC, TLI_VSYNC, EVENTOUT Additional: ADC01_IN4, DAC0_OUT0
PA5	30	I/O		Default: PA5 Alternate: TIMER1_CH0, TIMER1_ETI, TIMER7_CH0_ON, SPI0_SCK, USBHS_ULPI_CK, EVENTOUT Additional: ADC01_IN5, DAC0_OUT1
PA6	31	I/O	5VT	Default: PA6 Alternate: TIMER0_BRKIN, TIMER2_CH0, TIMER7_BRKIN, SPI0_MISO, I2S1_MCK, TIMER12_CH0, SDIO_CMD, DCI_PIXCLK, TLI_G2, EVENTOUT Additional: ADC01_IN6
PA7	32	I/O	5VT	Default: PA7 Alternate: TIMER0_CH0_ON, TIMER2_CH1, TIMER7_CH0_ON, SPI0_MOSI, TIMER13_CH0, ENET_MII_RX_DV, ENET_RMII_CRS_DV, EVENTOUT Additional: ADC01_IN7
PC4	33	I/O	5VT	Default: PC4 Alternate: ENET_MII_RXD0, ENET_RMII_RXD0, EVENTOUT Additional: ADC01_IN14
PC5	34	I/O	5VT	Default: PC5 Alternate: USART2_RX, ENET_MII_RXD1, ENET_RMII_RXD1, EVENTOUT Additional: ADC01_IN15
PB0	35	I/O	5VT	Default: PB0 Alternate: TIMER0_CH1_ON, TIMER2_CH2, TIMER7_CH1_ON, SPI4_SCK, SPI2_MOSI, I2S2_SD, TLI_R3, USBHS_ULPI_D1, ENET_MII_RXD2, SDIO_D1, EVENTOUT Additional: ADC01_IN8, IREF
PB1	36	I/O	5VT	Default: PB1 Alternate: TIMER0_CH2_ON, TIMER2_CH3, TIMER7_CH2_ON, SPI4_NSS, TLI_R6, USBHS_ULPI_D2, ENET_MII_RXD3, SDIO_D2, EVENTOUT Additional: ADC01_IN9
PB2	37	I/O	5VT	Default: PB2, BOOT1 Alternate: TIMER1_CH3, SPI2_MOSI, I2S2_SD, USBHS_ULPI_D4, SDIO_CK, EVENTOUT
PE7	38	I/O	5VT	Default: PE7

GD32F450Vx LQFP100				
Pin Name	Pins	Pin Type <sup>(1)</sup>	I/O Level <sup>(2)</sup>	Functions description
				Alternate: TIMER0_ETI, UART6_RX, EXMC_D4, EVENTOUT
PE8	39	I/O	5VT	Default: PE8 Alternate: TIMER0_CH0_ON, UART6_TX, EXMC_D5, EVENTOUT
PE9	40	I/O	5VT	Default: PE9 Alternate: TIMER0_CH0, EXMC_D6, EVENTOUT
PE10	41	I/O	5VT	Default: PE10 Alternate: TIMER0_CH1_ON, EXMC_D7, EVENTOUT
PE11	42	I/O	5VT	Default: PE11 Alternate: TIMER0_CH1, SPI3_NSS, SPI4_NSS, EXMC_D8, TLI_G3, EVENTOUT
PE12	43	I/O	5VT	Default: PE12 Alternate: TIMER0_CH2_ON, SPI3_SCK, SPI4_SCK, EXMC_D9, TLI_B4, EVENTOUT
PE13	44	I/O	5VT	Default: PE13 Alternate: TIMER0_CH2, SPI3_MISO, SPI4_MISO, EXMC_D10, TLI_DE, EVENTOUT
PE14	45	I/O	5VT	Default: PE14 Alternate: TIMER0_CH3, SPI3_MOSI, SPI4_MOSI, EXMC_D11, TLI_PIXCLK, EVENTOUT
PE15	46	I/O	5VT	Default: PE15 Alternate: TIMER0_BRKIN, EXMC_D12, TLI_R7, EVENTOUT
PB10	47	I/O	5VT	Default: PB10 Alternate: TIMER1_CH2, I2C1_SCL, SPI1_SCK, I2S1_CK, I2S2_MCK, USART2_TX, USBHS_ULPI_D3, ENET_MII_RX_ER, SDIO_D7, TLI_G4, EVENTOUT
PB11	48	I/O	5VT	Default: PB11 Alternate: TIMER1_CH3, I2C1_SDA, I2S_CKIN, USART2_RX, USBHS_ULPI_D4, ENET_MII_TX_EN, ENET_RMII_TX_EN, TLI_G5, EVENTOUT
NC	49	-	-	-
VDD	50	P	-	Default: VDD
PB12	51	I/O	5VT	Default: PB12 Alternate: TIMER0_BRKIN, I2C1_SMBA, SPI1_NSS, I2S1_WS, SPI3_NSS, USART2_CK, CAN1_RX, USBHS_ULPI_D5, ENET_MII_TXD0, ENET_RMII_TXD0, USBHS_ID, EVENTOUT
PB13	52	I/O	5VT	Default: PB13 Alternate: TIMER0_CH0_ON, SPI1_SCK, I2S1_CK, SPI3_SCK, USART2_CTS, CAN1_TX, USBHS_ULPI_D6, ENET_MII_TXD1, ENET_RMII_TXD1, EVENTOUT, I2C1_TXFRAME Additional: USBHS_VBUS

GD32F450Vx LQFP100				
Pin Name	Pins	Pin Type <sup>(1)</sup>	I/O Level <sup>(2)</sup>	Functions description
PB14	53	I/O	5VT	Default: PB14 Alternate: TIMER0_CH1_ON, TIMER7_CH1_ON, SPI1_MISO, I2S1_ADD_SD, USART2_RTS, TIMER11_CH0, USBHS_DM, EVENTOUT
PB15	54	I/O	5VT	Default: PB15 Alternate: RTC_REFIN, TIMER0_CH2_ON, TIMER7_CH2_ON, SPI1_MOSI, I2S1_SD, TIMER11_CH1, USBHS_DP, EVENTOUT
PD8	55	I/O	5VT	Default: PD8 Alternate: USART2_TX, EXMC_D13, EVENTOUT
PD9	56	I/O	5VT	Default: PD9 Alternate: USART2_RX, EXMC_D14, EVENTOUT
PD10	57	I/O	5VT	Default: PD10 Alternate: USART2_CK, EXMC_D15, TLI_B3, EVENTOUT
PD11	58	I/O	5VT	Default: PD11 Alternate: USART2_CTS, EXMC_A16/EXMC_CLE, EVENTOUT
PD12	59	I/O	5VT	Default: PD12 Alternate: TIMER3_CH0, USART2_RTS, EXMC_A17/EXMC_ALE, EVENTOUT
PD13	60	I/O	5VT	Default: PD13 Alternate: TIMER3_CH1, EXMC_A18, EVENTOUT
PD14	61	I/O	5VT	Default: PD14 Alternate: TIMER3_CH2, EXMC_D0, EVENTOUT
PD15	62	I/O	5VT	Default: PD15 Alternate: TIMER3_CH3, EXMC_D1, EVENTOUT, CTC_SYNC
PC6	63	I/O	5VT	Default: PC6 Alternate: TIMER2_CH0, TIMER7_CH0, I2S1_MCK, USART5_TX, SDIO_D6, DCI_D0, TLI_HSYNC, EVENTOUT
PC7	64	I/O	5VT	Default: PC7 Alternate: TIMER2_CH1, TIMER7_CH1, SPI1_SCK, I2S1_CK, I2S2_MCK, USART5_RX, SDIO_D7, DCI_D1, TLI_G6, EVENTOUT
PC8	65	I/O	5VT	Default: PC8 Alternate: TIMER2_CH2, TIMER7_CH2, USART5_CK, SDIO_D0, DCI_D2, EVENTOUT
PC9	66	I/O	5VT	Default: PC9 Alternate: CK_OUT1, TIMER2_CH3, TIMER7_CH3, I2C2_SDA, I2S_CKIN, SDIO_D1, DCI_D3, EVENTOUT
PA8	67	I/O	5VT	Default: PA8 Alternate: CK_OUT0, TIMER0_CH0, I2C2_SCL, USART0_CK, USBFS_SOF, SDIO_D1, TLI_R6, EVENTOUT, CTC_SYNC

GD32F450Vx LQFP100				
Pin Name	Pins	Pin Type <sup>(1)</sup>	I/O Level <sup>(2)</sup>	Functions description
PA9	68	I/O	5VT	Default: PA9 Alternate: TIMER0_CH1, I2C2_SMBA, SPI1_SCK, I2S1_CK, USART0_TX, SDIO_D2, DCI_D0, EVENTOUT Additional: USBFS_VBUS
PA10	69	I/O	5VT	Default: PA10 Alternate: TIMER0_CH2, SPI4_MOSI, USART0_RX, USBFS_ID, DCI_D1, EVENTOUT, I2C2_TXFRAME
PA11	70	I/O	5VT	Default: PA11 Alternate: TIMER0_CH3, SPI3_MISO, USART0_CTS, USART5_TX, CAN0_RX, USBFS_DM, TLI_R4, EVENTOUT
PA12	71	I/O	5VT	Default: PA12 Alternate: TIMER0_ETI, SPI4_MISO, USART0_RTS, USART5_RX, CAN0_TX, USBFS_DP, TLI_R5, EVENTOUT
PA13	72	I/O	5VT	Default: JTMS, SWDIO, PA13 Alternate: EVENTOUT
NC	73	-	-	-
VSS	74	P	-	Default: VSS
VDD	75	P	-	Default: VDD
PA14	76	I/O	5VT	Default: JTCK, SWCLK, PA14 Alternate: EVENTOUT
PA15	77	I/O	5VT	Default: JTDI, PA15 Alternate: TIMER1_CH0, TIMER1_ETI, SPI0_NSS, SPI2_NSS, I2S2_WS, USART0_TX, EVENTOUT
PC10	78	I/O	5VT	Default: PC10 Alternate: SPI2_SCK, I2S2_CK, USART2_TX, UART3_TX, SDIO_D2, DCI_D8, TLI_R2, EVENTOUT
PC11	79	I/O	5VT	Default: PC11 Alternate: I2S2_ADD_SD, SPI2_MISO, USART2_RX, UART3_RX, SDIO_D3, DCI_D4, EVENTOUT
PC12	80	I/O	5VT	Default: PC12 Alternate: I2C1_SDA, SPI2_MOSI, I2S2_SD, USART2_CK, UART4_TX, SDIO_CK, DCI_D9, EVENTOUT
PD0	81	I/O	5VT	Default: PD0 Alternate: SPI3_MISO, SPI2_MOSI, I2S2_SD, CAN0_RX, EXMC_D2, EVENTOUT
PD1	82	I/O	5VT	Default: PD1 Alternate: SPI1_NSS, I2S1_WS, CAN0_TX, EXMC_D3, EVENTOUT
PD2	83	I/O	5VT	Default: PD2 Alternate: TIMER2_ETI, UART4_RX, SDIO_CMD, DCI_D11, EVENTOUT
PD3	84	I/O	5VT	Default: PD3

GD32F450Vx LQFP100				
Pin Name	Pins	Pin Type <sup>(1)</sup>	I/O Level <sup>(2)</sup>	Functions description
				Alternate: SPI1_SCK, I2S1_CK, USART1_CTS, EXMC_CLK, DCI_D5, TLI_G7, EVENTOUT
PD4	85	I/O	5VT	Default: PD4 Alternate: USART1_RTS, EXMC_NOE, EVENTOUT
PD5	86	I/O	5VT	Default: PD5 Alternate: USART1_TX, EXMC_NWE, EVENTOUT
PD6	87	I/O	5VT	Default: PD6 Alternate: SPI2_MOSI, I2S2_SD, USART1_RX, EXMC_NWAIT, DCI_D10, TLI_B2, EVENTOUT
PD7	88	I/O	5VT	Default: PD7 Alternate: USART1_CK, EXMC_NE0/EXMC_NCE1, EVENTOUT
PB3	89	I/O	5VT	Default: JTDO, PB3 Alternate: TRACESWO, TIMER1_CH1, SPI0_SCK, SPI2_SCK, I2S2_CK, USART0_RX, I2C1_SDA, EVENTOUT
PB4	90	I/O	5VT	Default: JNTRST, PB4 Alternate: TIMER2_CH0, SPI0_MISO, SPI2_MISO, I2S2_ADD_SD, I2C2_SDA, SDIO_D0, EVENTOUT, I2C0_TXFRAME
PB5	91	I/O	5VT	Default: PB5 Alternate: TIMER2_CH1, I2C0_SMBA, SPI0_MOSI, SPI2_MOSI, I2S2_SD, CAN1_RX, USBHS_ULPI_D7, ENET_PPS_OUT, DCI_D10, EVENTOUT
PB6	92	I/O	5VT	Default: PB6 Alternate: TIMER3_CH0, I2C0_SCL, USART0_TX, CAN1_TX, DCI_D5, EVENTOUT
PB7	93	I/O	5VT	Default: PB7 Alternate: TIMER3_CH1, I2C0_SDA, USART0_RX, EXMC_NL/EXMC_NADV, DCI_VSYNC, EVENTOUT
BOOT0	94	I/O	5VT	Default: BOOT0
PB8	95	I/O	5VT	Default: PB8 Alternate: TIMER1_CH0, TIMER1_ETI, TIMER3_CH2, TIMER9_CH0, I2C0_SCL, SPI4_MOSI, CAN0_RX, ENET_MII_TXD3, SDIO_D4, DCI_D6, TLI_B6, EVENTOUT
PB9	96	I/O	5VT	Default: PB9 Alternate: TIMER1_CH1, TIMER3_CH3, TIMER10_CH0, I2C0_SDA, SPI1_NSS, I2S1_WS, CAN0_TX, SDIO_D5, DCI_D7, TLI_B7, EVENTOUT
PE0	97	I/O	5VT	Default: PE0 Alternate: TIMER3_ETI, UART7_RX, EXMC_NBL0, DCI_D2, EVENTOUT
PE1	98	I/O	5VT	Default: PE1 Alternate: TIMER0_CH1_ON, UART7_TX, EXMC_NBL1, DCI_D3, EVENTOUT

GD32F450Vx LQFP100				
Pin Name	Pins	Pin Type <sup>(1)</sup>	I/O Level <sup>(2)</sup>	Functions description
VSS	99	P	-	Default: VSS
VDD	100	P	-	Default: VDD

**Notes:**

- (1) Type: I = input, O = output, P = power.
- (2) I/O Level: 5VT = 5 V tolerant.

## 2.6.4. GD32F450xx pin alternate functions

**Table 2-6. Port A alternate functions summary**

Pin Name	AF0	AF1	AF2	AF3	AF4	AF5	AF6	AF7	AF8	AF9	AF10	AF11	AF12	AF13	AF14	AF15
PA0		TIMER1_CH0 /TIMER1_ETI	TIMER4_CH0	TIMER7_ETI				USART1_CTS	UART3_TX			ENET_MII_CRS				EVENTOUT
PA1		TIMER1_CH1	TIMER4_CH1				SPI3_MOSI	USART1_RTS	UART3_RX			ENET_MII_RX_CLK/ENET_RMII_REF_CLK				EVENTOUT
PA2		TIMER1_CH2	TIMER4_CH2	TIMER8_CH0			I2S_CKIN	USART1_TX				ENET_MDIO				EVENTOUT
PA3		TIMER1_CH3	TIMER4_CH3	TIMER8_CH1			I2S1_MCK	USART1_RX			USBHS_ULPI_D0	ENET_MII_COL			TLI_B5	EVENTOUT
PA4							SPI0_NSS	SPI2_NSS/I2S2_WS	USART1_CK				USBHS_SOF	DCI_HSYN_C	TLI_VSYN_C	EVENTOUT
PA5		TIMER1_CH0 /TIMER1_ETI		TIMER7_CH0_ON			SPI0_SCK				USBHS_ULPI_CK					EVENTOUT
PA6		TIMER0_BRKIN	TIMER2_CH0	TIMER7_BRKIN			SPI0_MISO	I2S1_MCK			TIMER12_CH0		SDIO_CMD	DCI_PIXCLK	TLI_G2	EVENTOUT
PA7		TIMER0_CH0_ON	TIMER2_CH1	TIMER7_CH0_ON			SPI0_MOSI			TIMER13_CH0		ENET_MII_RX_DV/ENET_RMII_CRS_DV	EXMC_SDNWE			EVENTOUT
PA8	CK_OUT0	TIMER0_CH0			I2C2_SCL			USART0_CK		CTC_SYNC	USBFS_SOF		SDIO_D1		TLI_R6	EVENTOUT
PA9		TIMER0_CH1			I2C2_SMB_A	SPI1_SCK/I2S1_CK		USART0_TX					SDIO_D2	DCI_D0		EVENTOUT
PA10		TIMER0_CH2			I2C2_TXFRAME		SPI4_MOSI	USART0_RX				USBFS_ID		DCI_D1		EVENTOUT
PA11		TIMER0_CH3					SPI3_MISO	USART0_CTS	USART5_TX	CAN0_RX	USBFS_DM				TLI_R4	EVENTOUT
PA12		TIMER0_ETI					SPI4_MISO	USART0_RTS	USART5_RX	CAN0_TX	USBFS_DP				TLI_R5	EVENTOUT
PA13	JTMS/SWDIO															EVENTOUT
PA14	JTCK/SWCLK															EVENTOUT



Pin Name	AF0	AF1	AF2	AF3	AF4	AF5	AF6	AF7	AF8	AF9	AF10	AF11	AF12	AF13	AF14	AF15
PA15	JTDI	TIMER1_CH0/TIMER1_ETI				SPI0_NSS	SPI2_NSS/I2S2_WS	USART0_TX								EVENTOUT

Table 2-7. Port B alternate functions summary

Pin Name	AF0	AF1	AF2	AF3	AF4	AF5	AF6	AF7	AF8	AF9	AF10	AF11	AF12	AF13	AF14	AF15
PB0		TIMER0_C H1_ON	TIMER2_C H2	TIMER7_C H1_ON			SPI4_SCK	SPI2_MOSI/I2S2_SD		TLI_R3	USBHS_ULPI_D1	ENET_MII_RXD2	SDIO_D1			EVENTOUT
PB1		TIMER0_C H2_ON	TIMER2_C H3	TIMER7_C H2_ON			SPI4_NSS			TLI_R6	USBHS_ULPI_D2	ENET_MII_RXD3	SDIO_D2			EVENTOUT
PB2		TIMER1_C H3						SPI2_MOSI/I2S2_SD			USBHS_ULPI_D4		SDIO_CLK			EVENTOUT
PB3	JTDO/TRACESWO	TIMER1_C H1				SPI0_SCK	SPI2_SCK/I2S2_CK	USART0_RX		I2C1_SDA						EVENTOUT
PB4	NJTRST		TIMER2_C H0		I2C0_TXF RAME	SPI0_MISO	SPI2_MISO	I2S2_ADD_SD		I2C2_SDA			SDIO_D0			EVENTOUT
PB5			TIMER2_C H1		I2C0_SMB A	SPI0_MOSI	SPI2_MOSI/I2S2_SD			CAN1_RX	USBHS_ULPI_D7	ENET_PPS_OUT	EXMC_SDCKE1	DCI_D10		EVENTOUT
PB6			TIMER3_C H0		I2C0_SCL			USART0_TX		CAN1_TX			EXMC_SDNE1	DCI_D5		EVENTOUT
PB7			TIMER3_C H1		I2C0_SDA			USART0_RX					EXMC_NL/EXMC_NADV	DCI_VSYN C		EVENTOUT
PB8		TIMER1_C H0/TIMER1_ETI	TIMER3_C H2	TIMER9_C H0	I2C0_SCL		SPI4_MOSI			CAN0_RX		ENET_MII_TXD3	SDIO_D4	DCI_D6	TLI_B6	EVENTOUT
PB9		TIMER1_C H1	TIMER3_C H3	TIMER10_CH0	I2C0_SDA	SPI1_NSS/I2S1_WS				CAN0_TX			SDIO_D5	DCI_D7	TLI_B7	EVENTOUT
PB10		TIMER1_C H2			I2C1_SCL	SPI1_SCK/I2S1_CK	I2S2_MCK	USART2_TX			USBHS_ULPI_D3	ENET_MII_RX_ER	SDIO_D7		TLI_G4	EVENTOUT
PB11		TIMER1_C H3			I2C1_SDA	I2S_CKIN		USART2_RX			USBHS_ULPI_D4	ENET_MII_TX_EN/ENET_RMII_TX_EN			TLI_G5	EVENTOUT
PB12		TIMER0_BRKIN			I2C1_SMB A	SPI1_NSS/I2S1_WS	SPI3_NSS	USART2_CLK		CAN1_RX	USBHS_ULPI_D5	ENET_MII_TXD0/ENET_RMII_TXD0	USBHS_ID			EVENTOUT
PB13		TIMER0_C H0_ON			I2C1_TXF RAME	SPI1_SCK/I2S1_CK	SPI3_SCK	USART2_CTS		CAN1_TX	USBHS_ULPI_D6	ENET_MII_TXD1/ENET_RMII_TXD1				EVENTOUT
PB14		TIMER0_C H1_ON		TIMER7_C H1_ON		SPI1_MISO	I2S1_ADD_SD	USART2_RTS		TIMER11_CH0			USBHS_DM			EVENTOUT

Pin Name	AF0	AF1	AF2	AF3	AF4	AF5	AF6	AF7	AF8	AF9	AF10	AF11	AF12	AF13	AF14	AF15	
PB15	RTC_REFI N	TIMER0_C H2_ON		TIMER7_C H2_ON		SPI1_MOS I/I2S1_SD						TIMER11_ CH1		USBHS_ DP			EVENTOUT

Table 2-8. Port C alternate functions summary

Pin Name	AF0	AF1	AF2	AF3	AF4	AF5	AF6	AF7	AF8	AF9	AF10	AF11	AF12	AF13	AF14	AF15
PC0											USBHS_U LPI_STP		EXMC_SD NWE			EVENTOUT
PC1						SPI2_MOS I/I2S2_SD		SPI1_MOS/ I2S1_SD				ENET_MD C				EVENTOUT
PC2						SPI1_MIS O	I2S1_ADD _SD				USBHS_U LPI_DIR	ENET_MII _TXD2	EXMC_SD NE0			EVENTOUT
PC3						SPI1_MOS I/I2S1_SD					USBHS_U LPI_NXT	ENET_MII _TX_CLK	EXMC_SD CKE0			EVENTOUT
PC4												ENET_MII _RXD0/EN ET_RMII_ RXD0	EXMC_SD NE0			EVENTOUT
PC5								USART2_R X				ENET_MII _RXD1/EN ET_RMII_ RXD1	EXMC_SD CKE0			EVENTOUT
PC6			TIMER2_C H0	TIMER7_C H0		I2S1_MCK			USART5_TX				SDIO_D6	DCI_D0	TLI_HS YNC	EVENTOUT
PC7			TIMER2_C H1	TIMER7_C H1		SPI1_SCK/ I2S1_CK	I2S2_MCK		USART5_RX				SDIO_D7	DCI_D1	TLI_G6	EVENTOUT
PC8			TIMER2_C H2	TIMER7_C H2					USART5_CK				SDIO_D0	DCI_D2		EVENTOUT
PC9	CK_OUT1		TIMER2_C H3	TIMER7_C H3	I2C2_SDA	I2S_CKIN							SDIO_D1	DCI_D3		EVENTOUT
PC10							SPI2_SCK/ I2S2_CK	USART2_T X	UART3_TX				SDIO_D2	DCI_D8	TLI_R2	EVENTOUT
PC11							I2S2_ADD _SD	SPI2_MIS O	USART2_R X	UART3_RX			SDIO_D3	DCI_D4		EVENTOUT
PC12					I2C1_SDA		SPI2_MOS I/I2S2_SD	USART2_C K	UART4_TX				SDIO_CK	DCI_D9		EVENTOUT
PC13																EVENTOUT
PC14																EVENTOUT



Pin Name	AF0	AF1	AF2	AF3	AF4	AF5	AF6	AF7	AF8	AF9	AF10	AF11	AF12	AF13	AF14	AF15
PC15																EVENTOUT

Table 2-9. Port D alternate functions summary

Pin Name	AF0	AF1	AF2	AF3	AF4	AF5	AF6	AF7	AF8	AF9	AF10	AF11	AF12	AF13	AF14	AF15
PD0						SPI3_MISO	SPI2_MOS I/I2S2_SD			CAN0_R X			EXMC_D2			EVENTOUT
PD1								SPI1_NSS/ I2S1_WS		CAN0_T X			EXMC_D3			EVENTOUT
PD2			TIMER2_ETI						UART4_RX				SDIO_CMD	DCI_D11		EVENTOUT
PD3						SPI1_SCK/I 2S1_CK		USART1_ CTS					EXMC_CLK	DCI_D5	TLI_G7	EVENTOUT
PD4								USART1_ RTS					EXMC_NOE			EVENTOUT
PD5								USART1_T X					EXMC_NWE			EVENTOUT
PD6						SPI2_MOSI/ I2S2_SD		USART1_ RX					EXMC_NWAI T	DCI_D10	TLI_B2	EVENTOUT
PD7								USART1_ CK					EXMC_NE0/ EXMC_NCE1			EVENTOUT
PD8								USART2_T X					EXMC_D13			EVENTOUT
PD9								USART2_ RX					EXMC_D14			EVENTOUT
PD10								USART2_ CK					EXMC_D15		TLI_B3	EVENTOUT
PD11								USART2_ CTS					EXMC_A16/E XMC_CLE			EVENTOUT
PD12			TIMER3_CH0					USART2_ RTS					EXMC_A17/E XMC_ALE			EVENTOUT
PD13			TIMER3_CH1										EXMC_A18			EVENTOUT
PD14			TIMER3_CH2										EXMC_D0			EVENTOUT



Pin Name	AF0	AF1	AF2	AF3	AF4	AF5	AF6	AF7	AF8	AF9	AF10	AF11	AF12	AF13	AF14	AF15
PD15	CTC_SYN C		TIMER3_CH3										EXMC_D1			EVENTOUT

Table 2-10. Port E alternate functions summary

Pin Name	AF0	AF1	AF2	AF3	AF4	AF5	AF6	AF7	AF8	AF9	AF10	AF11	AF12	AF13	AF14	AF15
PE0			TIMER3_ETI						UART7_RX				EXMC_NBL0	DCI_D2		EVENTOUT
PE1		TIMER0_CH1_ON							UART7_TX				EXMC_NBL1	DCI_D3		EVENTOUT
PE2						SPI3_SCK						ENET_MII_TXD3	EXMC_A23			EVENTOUT
PE3													EXMC_A19			EVENTOUT
PE4						SPI3_NSS							EXMC_A20	DCI_D4	TLI_B0	EVENTOUT
PE5				TIMER8_CH0		SPI3_MISO							EXMC_A21	DCI_D6	TLI_G0	EVENTOUT
PE6				TIMER8_CH1		SPI3_MOSI							EXMC_A22	DCI_D7	TLI_G1	EVENTOUT
PE7		TIMER0_ETI							UART6_RX				EXMC_D4			EVENTOUT
PE8		TIMER0_CH0_ON							UART6_TX				EXMC_D5			EVENTOUT
PE9		TIMER0_CH0											EXMC_D6			EVENTOUT
PE10		TIMER0_CH1_ON											EXMC_D7			EVENTOUT
PE11		TIMER0_CH1				SPI3_NSS	SPI4_NSS						EXMC_D8		TLI_G3	EVENTOUT
PE12		TIMER0_CH2_ON				SPI3_SCK	SPI4_SCK						EXMC_D9		TLI_B4	EVENTOUT
PE13		TIMER0_CH2				SPI3_MISO	SPI4_MISO						EXMC_D10		TLI_DE	EVENTOUT
PE14		TIMER0_CH3				SPI3_MOSI	SPI4_MOSI						EXMC_D11		TLI_PIXCLK	EVENTOUT



Pin Name	AF0	AF1	AF2	AF3	AF4	AF5	AF6	AF7	AF8	AF9	AF10	AF11	AF12	AF13	AF14	AF15
PE15		TIMER0_BRK IN											EXMC_D12		TLI_R7	EVENTOUT

**Table 2-11. Port F alternate functions summary**

Pin Name	AF0	AF1	AF2	AF3	AF4	AF5	AF6	AF7	AF8	AF9	AF10	AF11	AF12	AF13	AF14	AF15
PF0	CTC_SYN C				I2C1_SDA								EXMC_A0			EVENTOUT
PF1					I2C1_SCL								EXMC_A1			EVENTOUT
PF2					I2C1_SMB A								EXMC_A2			EVENTOUT
PF3					I2C1_TXF RAME								EXMC_A3			EVENTOUT
PF4													EXMC_A4			EVENTOUT
PF5													EXMC_A5			EVENTOUT
PF6				TIMER9_C H0		SPI4_NSS			UART6_R X				EXMC_NIORD			EVENTOUT
PF7				TIMER10_ CH0		SPI4_SCK			UART6_TX				EXMC_NREG			EVENTOUT
PF8						SPI4_MISO					TIMER12_ CH0		EXMC_NIOWR			EVENTOUT
PF9						SPI4_MOSI					TIMER13_ CH0		EXMC_CD			EVENTOUT
PF10													EXMC_INTR	DCI_D11	TLI_DE	EVENTOUT
PF11						SPI4_MOSI							EXMC_SDNRAS	DCI_D12		EVENTOUT
PF12													EXMC_A6			EVENTOUT
PF13													EXMC_A7			EVENTOUT
PF14													EXMC_A8			EVENTOUT



Pin Name	AF0	AF1	AF2	AF3	AF4	AF5	AF6	AF7	AF8	AF9	AF10	AF11	AF12	AF13	AF14	AF15
PF15													EXMC_A9			EVENTOUT

Table 2-12. Port G alternate functions summary

Pin Name	AF0	AF1	AF2	AF3	AF4	AF5	AF6	AF7	AF8	AF9	AF10	AF11	AF12	AF13	AF14	AF15
PG0													EXMC_A10			EVENTOUT
PG1													EXMC_A11			EVENTOUT
PG2													EXMC_A12			EVENTOUT
PG3													EXMC_A13			EVENTOUT
PG4													EXMC_A14			EVENTOUT
PG5													EXMC_A15			EVENTOUT
PG6													EXMC_INT1	DCI_D12	TLI_R7	EVENTOUT
PG7									USART5_CK				EXMC_INT2	DCI_D13	TLI_PIX CLK	EVENTOUT
PG8						SPI5_NSS			USART5_RTS			ENET_PP S_OUT	EXMC_SD CLK			EVENTOUT
PG9									USART5_RX				EXMC_NE1/EXMC_NCE2	DCI_VSYN C		EVENTOUT
PG10						SPI5_IO2					TLI_G3		EXMC_NC E3_0/EXM C_NE2	DCI_D2	TLI_B2	EVENTOUT
PG11						SPI5_IO3	SPI3_SCK					ENET_MII_TX_EN/E NET_RMII_TX_EN	EXMC_NC E3_1	DCI_D3	TLI_B3	EVENTOUT
PG12						SPI5_MISO	SPI3_MISO		USART5_RTS		TLI_B4		EXMC_NE3		TLI_B1	EVENTOUT
PG13						SPI5_SCK	SPI3_MOSI		USART5_CTS			ENET_MII_TXD0/EN ET_RMII_TXD0	EXMC_A24			EVENTOUT



Pin Name	AF0	AF1	AF2	AF3	AF4	AF5	AF6	AF7	AF8	AF9	AF10	AF11	AF12	AF13	AF14	AF15
PG14						SPI5_MOSI	SPI3_NSS		USART5_TX			ENET_MII_TXD1/ENET_RMII_TXD1	EXMC_A25			EVENTOUT
PG15									USART5_CTS				EXMC_SDNCAS	DCI_D13		EVENTOUT

Table 2-13. Port H alternate functions summary

Pin Name	AF0	AF1	AF2	AF3	AF4	AF5	AF6	AF7	AF8	AF9	AF10	AF11	AF12	AF13	AF14	AF15
PH0																EVENTOUT
PH1																EVENTOUT
PH2												ENET_MII_CRS	EXMC_SDCKE0		TLI_R0	EVENTOUT
PH3					I2C1_TXFRAME							ENET_MII_COL	EXMC_SDNE0		TLI_R1	EVENTOUT
PH4					I2C1_SCL						USBHS_ULPI_NXT					EVENTOUT
PH5					I2C1_SDA	SPI4_NSS							EXMC_SDNWE			EVENTOUT
PH6					I2C1_SMBA	SPI4_SCK				TIMER11_CH0		ENET_MII_RXD2	EXMC_SDNE1	DCI_D8		EVENTOUT
PH7					I2C2_SCL	SPI4_MISO						ENET_MII_RXD3	EXMC_SDCKE1	DCI_D9		EVENTOUT
PH8					I2C2_SDA								EXMC_D16	DCI_HSYNC	TLI_R2	EVENTOUT
PH9					I2C2_SMBA					TIMER11_CH1			EXMC_D17	DCI_D0	TLI_R3	EVENTOUT
PH10			TIMER4_CH0		I2C2_TXFRAME								EXMC_D18	DCI_D1	TLI_R4	EVENTOUT
PH11			TIMER4_CH1										EXMC_D19	DCI_D2	TLI_R5	EVENTOUT
PH12			TIMER4_CH2										EXMC_D20	DCI_D3	TLI_R6	EVENTOUT
PH13				TIMER7_CH0_ON						CAN0_TX			EXMC_D21		TLI_G2	EVENTOUT



Pin Name	AF0	AF1	AF2	AF3	AF4	AF5	AF6	AF7	AF8	AF9	AF10	AF11	AF12	AF13	AF14	AF15
PH14				TIMER7_C H1_ON									EXMC_D22	DCI_D4	TLI_G3	EVENTOUT
PH15				TIMER7_C H2_ON									EXMC_D23	DCI_D1 1	TLI_G4	EVENTOUT

Table 2-14. Port I alternate functions summary

Pin Name	AF0	AF1	AF2	AF3	AF4	AF5	AF6	AF7	AF8	AF9	AF10	AF11	AF12	AF13	AF14	AF15
PI0			TIMER4_C H3			SPI1_NSS/ I2S1_WS							EXMC_D24	DCI_D13	TLI_G5	EVENTOUT
PI1						SPI1_SCK/ I2S1_CK							EXMC_D25	DCI_D8	TLI_G6	EVENTOUT
PI2				TIMER7_C H3		SPI1_MIS O	I2S1_ADD _SD						EXMC_D26	DCI_D9	TLI_G7	EVENTOUT
PI3				TIMER7_E TI		SPI1_MOS I/I2S1_SD							EXMC_D27	DCI_D10		EVENTOUT
PI4				TIMER7_B RKIN									EXMC_NBL 2	DCI_D5	TLI_B4	EVENTOUT
PI5				TIMER7_C H0									EXMC_NBL 3	DCI_VSYN C	TLI_B5	EVENTOUT
PI6				TIMER7_C H1									EXMC_D28	DCI_D6	TLI_B6	EVENTOUT
PI7				TIMER7_C H2									EXMC_D29	DCI_D7	TLI_B7	EVENTOUT
PI8																EVENTOUT
PI9										CAN0_RX			EXMC_D30		TLI_VS YNC	EVENTOUT
PI10												ENET_MII _RX_ER	EXMC_D31		TLI_HS YNC	EVENTOUT
PI11											USBHS_U LPI_DIR					EVENTOUT

## 3. Functional description

### 3.1. Arm<sup>®</sup> Cortex<sup>®</sup>-M4 core

The Arm<sup>®</sup> Cortex<sup>®</sup>-M4 processor is a high performance embedded processor with DSP instructions which allow efficient signal processing and complex algorithm execution. It brings an efficient, easy-to-use blend of control and signal processing capabilities to meet the digital signal control markets demand. The processor is highly configurable enabling a wide range of implementations from those requiring floating point operations, memory protection and powerful trace technology to cost sensitive devices requiring minimal area, while delivering outstanding computational performance and an advanced system response to interrupts.

32-bit Arm<sup>®</sup> Cortex<sup>®</sup>-M4 processor core

- Up to 200 MHz operation frequency
- Single-cycle multiplication and hardware divider
- Floating Point Unit (FPU)
- Integrated DSP instructions
- Integrated Nested Vectored Interrupt Controller (NVIC)
- 24-bit SysTick timer

The Cortex<sup>®</sup>-M4 processor is based on the Armv7-M architecture and supports both Thumb and Thumb-2 instruction sets. Some system peripherals listed below are also provided by Cortex<sup>®</sup>-M4:

- Internal Bus Matrix connected with ICode bus, DCode bus, system bus, Private Peripheral Bus (PPB) and debug accesses (AHB-AP)
- Nested Vectored Interrupt Controller (NVIC)
- Flash Patch and Breakpoint (FPB)
- Data Watchpoint and Trace (DWT)
- Instrument Trace Macrocell (ITM)
- Memory Protection Unit (MPU)
- Serial Wire JTAG Debug Port (SWJ-DP)
- Trace Port Interface Unit (TPIU)

### 3.2. On-chip memory

- Up to 3072 Kbytes of Flash memory, including code Flash and data Flash
- The region of the MCU executing instructions without waiting time is up to 512K bytes (in case that Flash size equal to 512K, all memory is no waiting time). A long delay when CPU fetches the instructions out of the range.
- 256 KB to 512 KB of SRAM

The Arm<sup>®</sup> Cortex<sup>®</sup>-M4 processor is structured in Harvard architecture which can use separate

buses to fetch instructions and load/store data. 3072 Kbytes of inner Flash at most, which includes code Flash and data Flash is available for storing programs and data, and there is no waiting time within code Flash area when CPU executes instructions. Up to 512 Kbytes of inner SRAM is composed of SRAM0 (112KB), SRAM1 (16KB), SRAM2 (64KB) and ADDSRAM (256KB) that can be accessed at same time, and including 64 KB of TCM (tightly-coupled memory) data RAM that can be accessed only by the data bus of the Cortex®-M4 core. The additional 4KB of backup SRAM (BKP SRAM) is implemented in the backup domain, which can keep its content even when the  $V_{DD}$  power supply is down. [Table 2-2. GD32F450xx memory map](#) shows the memory map of the GD32F450xx series of devices, including Flash, SRAM, peripheral, and other pre-defined regions.

### 3.3. Clock, reset and supply management

- Internal 16 MHz factory-trimmed RC and external 4 to 32 MHz crystal oscillator
- Internal 48 MHz RC oscillator
- Internal 32 KHz RC calibrated oscillator and external 32.768 KHz crystal oscillator
- Integrated system clock PLL
- 2.6 to 3.6 V application supply and I/Os
- Supply Supervisor: POR (Power On Reset), PDR (Power Down Reset), and low voltage detector (LVD)

The Clock Control Unit (CCU) provides a range of oscillator and clock functions. These include internal RC oscillator and external crystal oscillator, high speed and low speed two types. Several prescalers allow the frequency configuration of the AHB and two APB domains. The maximum frequency of the two AHB domains are 200 MHz. The maximum frequency of the two APB domains including APB1 is 50 MHz and APB2 is 100 MHz. See [Figure 2-5. GD32F450xx clock tree](#) for details on the clock tree.

The Reset Control Unit (RCU) controls three kinds of reset: system reset resets the processor core and peripheral IP components. Power-on reset (POR) and power-down reset (PDR) are always active, and ensures proper operation starting from 2.4 V and down to 1.8V. The device remains in reset mode when  $V_{DD}$  is below a specified threshold. The embedded low voltage detector (LVD) monitors the power supply, compares it to the voltage threshold and generates an interrupt as a warning message for leading the MCU into security.

Power supply schemes:

- $V_{DD}$  range: 2.6 to 3.6 V, external power supply for I/Os and the internal regulator. Provided externally through VDD pins.
- $V_{SSA}$ ,  $V_{DDA}$  range: 2.6 to 3.6 V, external analog power supplies for ADC, reset blocks, RCs and PLL.  $V_{DDA}$  and  $V_{SSA}$  must be connected to VDD and VSS, respectively.
- $V_{BAT}$  range: 1.8 to 3.6 V, power supply for RTC, external clock 32 KHz oscillator and backup registers (through power switch) when  $V_{DD}$  is not present.

### 3.4. Boot modes

At startup, boot pins are used to select one of three boot options:

- Boot from main Flash memory (default)
- Boot from system memory
- Boot from on-chip SRAM

The boot loader is located in the internal 30KB of information blocks for the boot ROM memory (system memory). It is used to reprogram the Flash memory by using USART0 (PA9 and PA10), USART2 (PB10 and PB11, or PC10 and PC11), and USBFS (PA9, PA10, PA11 and PA12) in device mode. It also can be used to transfer and update the Flash memory code, the data and the vector table sections. In default condition, boot from bank 0 of Flash memory is selected. It also supports to boot from bank 1 of Flash memory by setting a bit in option bytes.

### 3.5. Power saving modes

The MCU supports three kinds of power saving modes to achieve even lower power consumption. They are sleep mode, deep-sleep mode, and standby mode. These operating modes reduce the power consumption and allow the application to achieve the best balance between the CPU operating time, speed and power consumption.

- **Sleep mode**

In sleep mode, only the clock of CPU core is off. All peripherals continue to operate and any interrupt/event can wake up the system.

- **Deep-sleep mode**

In deep-sleep mode, all clocks in the  $V_{CORE}$  domain are off, and all of the high speed crystal oscillator (IRC16M, HXTAL) and PLL are disabled. Only the contents of SRAM and registers are retained. Any interrupt or wakeup event from EXTI lines can wake up the system from the deep-sleep mode including the 16 external lines, the RTC alarm, RTC Tamper and TimeStamp event, the LVD output, ENET wakeup, RTC wakeup and USB wakeup. When exiting the deep-sleep mode, the IRC16M is selected as the system clock.

- **Standby mode**

In standby mode, the whole  $V_{CORE}$  domain is power off, the LDO is shut down, and all of IRC16M, HXTAL and PLL are disabled. The contents of SRAM and registers (except backup registers) are lost. There are four wakeup sources for the standby mode, including the external reset from NRST pin, the RTC, the FWDGT reset, and the rising edge on WKUP pin.

### 3.6. Analog to digital converter (ADC)

- 12-bit SAR ADC's conversion rate is up to 2.6 MSPS

- 12-bit, 10-bit, 8-bit or 6-bit configurable resolution
- Hardware oversampling ratio adjustable from 2 to 256x improves resolution to 16-bit
- Input voltage range:  $V_{REFN}$  to  $V_{REFP}$
- Temperature sensor

Up to three 12-bit 2.6 MSPS multi-channel ADCs are integrated in the device. It has a total of 19 multiplexed channels: 16 external channels, 1 channel for internal temperature sensor ( $V_{SENSE}$ ), 1 channel for internal reference voltage ( $V_{REFINT}$ ) and 1 channel for external battery power supply ( $V_{BAT}$ ). An on-chip hardware oversampling scheme improves performance while off-loading the related computational burden from the CPU. An analog watchdog block can be used to detect the channels, which are required to remain within a specific threshold window. A configurable channel management block can be used to perform conversions in single, continuous, scan or discontinuous mode to support more advanced use.

The ADC can be triggered from the events generated by the general level 0 timers (TIMERx) and the advanced timers (TIMER0 and TIMER7) with internal connection. The temperature sensor can be used to generate a voltage that varies linearly with temperature. It is internally connected to the ADC\_IN16 input channel which is used to convert the sensor output voltage in a digital value.

To ensure a high accuracy on ADC, the ADC independent external reference voltage should be connected to VREFP/VREFN pins. According to the different packages, VREFP pin can be connected to VDDA pin, or external reference voltage, VREFN pin must be connected to VSSA pin. For packages without VREFP and VREFN pins,  $V_{REFP}$  is internally connected to  $V_{DDA}$ , and  $V_{REFN}$  is internally connected to  $V_{SSA}$ .

### 3.7. Digital to analog converter (DAC)

- Two 12-bit DAC converter of independent output channel
- 8-bit or 12-bit mode in conjunction with the DMA controller

The 12-bit buffered DAC channel is used to generate variable analog outputs. The DACs are designed with integrated resistor strings structure. The DAC channels can be triggered by the timer update outputs or EXTI with DMA support. The maximum output value of the DAC is  $V_{REFP}$ .

### 3.8. DMA

- 16 channels DMA controller and each channel are configurable (8 for DMA0 and 8 for DMA1)
- Support independent 8, 16, 32-bit memory and peripheral transfer
- Peripherals supported: Timers, ADC, SPIs, I2Cs, USARTs, UARTs, DAC, I2S, SDIO and DCI

The flexible general-purpose DMA controllers provide a hardware method of transferring data

between peripherals and/or memory without intervention from the CPU, thereby freeing up bandwidth for other system functions. Three types of access method are supported: peripheral to memory, memory to peripheral, memory to memory.

Each channel is connected to fixed hardware DMA requests. The priorities of DMA channel requests are determined by software configuration and hardware channel number. Transfer size of source and destination are independent and configurable.

### 3.9. General-purpose inputs/outputs (GPIOs)

- Up to 140 fast GPIOs, all mappable on 16 external interrupt lines
- Analog input/output configurable
- Alternate function input/output configurable

There are up to 140 general purpose I/O pins (GPIO) in GD32F450xx, named PA0 ~ PA15, PB0 ~ PB15, PC0 ~ PC15, PD0 ~ PD15, PE0 ~ PE15, PF0 ~ PF15, PG0 ~ PG15, PH0 ~ PH15 and PI0 ~ PI11 to implement logic input/output functions. Each of the GPIO ports has related control and configuration registers to satisfy the requirements of specific applications. The external interrupts on the GPIO pins of the device have related control and configuration registers in the Interrupt/event controller (EXTI). The GPIO ports are pin-shared with other alternative functions (AFs) to obtain maximum flexibility on the package pins. Each of the GPIO pins can be configured by software as output (push-pull or open-drain), as input (with or without pull-up or pull-down) or as peripheral alternate function. Most of the GPIO pins are shared with digital or analog alternate functions. All GPIOs are high-current capable except for analog inputs.

### 3.10. Timers and PWM generation

- Two 16-bit advanced timer (TIMER0 & TIMER7), eight 16-bit general timers (TIMER2, TIMER3, TIMER8 ~ TIMER13), two 32-bit general timers (TIMER1 & TIMER4) and two 16-bit basic timer (TIMER5 & TIMER6)
- Up to 4 independent channels of PWM, output compare or input capture for each general timer and external trigger input
- 16-bit, motor control PWM advanced timer with programmable dead-time generation for output match
- Encoder interface controller with two inputs using quadrature decoder
- 24-bit SysTick timer down counter
- 2 watchdog timers (free watchdog timer and window watchdog timer)

The advanced timer (TIMER0 & TIMER7) can be used as a three-phase PWM multiplexed on 6 channels. It has complementary PWM outputs with programmable dead-time generation. It can also be used as a complete general timer. The 4 independent channels can be used for input capture, output compare, PWM generation (edge-aligned or center-aligned counting modes) and single pulse mode output. If configured as a general 16-bit timer, it has the same

functions as the TIMERx timer. It can be synchronized with external signals or to interconnect with other general timers together which have the same architecture and features.

The general timer, can be used for a variety of purposes including general timer, input signal pulse width measurement or output waveform generation such as a single pulse generation or PWM output, up to 4 independent channels for input capture/output compare. TIMER1 & TIMER4 is based on a 32-bit auto-reload up/downcounter and a 16-bit prescaler. TIMER2 & TIMER3 is based on a 16-bit auto-reload up/downcounter and a 16-bit prescaler. TIMER8 ~ TIMER13 is based on a 16-bit auto-reload upcounter and a 16-bit prescaler. The general timer also supports an encoder interface with two inputs using quadrature decoder.

The basic timer, known as TIMER5 & TIMER6, are mainly used for DAC trigger generation. They can also be used as a simple 16-bit time base.

The GD32F450xx have two watchdog peripherals, free watchdog timer and window watchdog timer. They offer a combination of high safety level, flexibility of use and timing accuracy.

The free watchdog timer includes a 12-bit down-counting counter and an 8-bit prescaler. It is clocked from an independent 32 KHz internal RC and as it operates independently of the main clock, it can operate in deep-sleep and standby modes. It can be used either as a watchdog to reset the device when a problem occurs, or as a free-running timer for application timeout management.

The window watchdog timer is based on a 7-bit down counter that can be set as free-running. It can be used as a watchdog to reset the device when a problem occurs. It is clocked from the main clock. It has an early wakeup interrupt capability and the counter can be frozen in debug mode.

The SysTick timer is dedicated for OS, but could also be used as a standard down counter. It features:

- A 24-bit down counter
- Auto reload capability
- Maskable system interrupt generation when the counter reaches 0
- Programmable clock source

### 3.11. Real time clock (RTC) and backup registers

- Independent binary-coded decimal (BCD) format timer/counter with twenty 32-bit backup registers.
- Calendar with sub-second, seconds, minutes, hours, week day, date, year and month automatically correction
- Alarm function with wake up from deep-sleep and standby mode capability
- On-the-fly correction for synchronization with master clock. Digital calibration with 1 ppm resolution for compensation of quartz crystal inaccuracy.

The real time clock is an independent timer which provides a set of continuously running counters in backup registers to provide a real calendar function, and provides an alarm

interrupt or an expected interrupt. It is not reset by a system or power reset, or when the device wakes up from standby mode. A prescaler is used for the time base clock and is by default configured to generate a time base of 1 second from a clock at 32.768 KHz from external crystal oscillator.

### 3.12. Inter-integrated circuit (I2C)

- Up to three I2C bus interfaces can support both master and slave mode with a frequency up to 400 KHz (Fast mode)
- Provide arbitration function, optional PEC (packet error checking) generation and checking
- Supports 7-bit and 10-bit addressing mode and general call addressing mode

The I2C interface is an internal circuit allowing communication with an external I2C interface which is an industry standard two line serial interface used for connection to external hardware. These two serial lines are known as a serial data line (SDA) and a serial clock line (SCL). The I2C module provides transfer rate of up to 100 KHz in standard mode and up to 400 KHz in fast mode. The I2C module also has an arbitration detect function to prevent the situation where more than one master attempts to transmit data to the I2C bus at the same time. A CRC-8 calculator is also provided in I2C interface to perform packet error checking for I2C data.

### 3.13. Serial peripheral interface (SPI)

- Master or slave operation with full-duplex or simplex mode
- Support both master and slave mode
- Hardware CRC calculation and transmit automatic CRC error checking
- Quad wire configuration available in master mode (only in SPI5)

The SPI interface uses 4 pins, among which are the serial data input and output lines (MISO & MOSI), the clock line (SCK) and the slave select line (NSS). Both SPIs can be served by the DMA controller. The SPI interface may be used for a variety of purposes, including simplex synchronous transfers on two lines with a possible bidirectional data line or reliable communication using CRC checking. Quad-SPI master mode is also supported in SPI5 (SPI5 is not available in GD32F450Vx series).

### 3.14. Universal synchronous/asynchronous receiver transmitter (USART/UART)

- Maximum speed up to 12.5MBit/s for USART0 and USART5
- Maximum speed up to 6.25MBit/s for USART1, USART2, UART3, UART4, UART6 and UART7

- Supports both asynchronous and clocked synchronous serial communication modes
- IrDA SIR encoder and decoder support
- LIN break generation and detection
- ISO 7816-3 compliant smart card interface

The USART (USART0, USART1, USART2, USART5) and UART (UART3, UART4, UART6, UART7) are used to transfer data between parallel and serial interfaces, provides a flexible full duplex data exchange using synchronous or asynchronous transfer. It is also commonly used for RS-232 standard communication. The USART/UART includes a programmable baud rate generator which is capable of dividing the system clock to produce a dedicated clock for the USART/UART transmitter and receiver. The USART/UART also supports DMA function for high speed data communication.

### 3.15. Inter-IC sound (I2S)

- Two I2S bus Interfaces with sampling frequency from 8 KHz to 192 KHz, multiplexed with SPI1 and SPI2
- Support either master or slave mode Audio
- Sampling frequencies from 8 KHz up to 192 KHz are supported

The Inter-IC sound (I2S) bus provides a standard communication interface for digital audio applications by 4-wire serial lines. GD32F450xx contain an I2S-bus interface that can be operated with 16/32 bit resolution in master or slave mode, pin multiplexed with SPI1 and SPI2. The audio sampling frequencies from 8 KHz to 192 KHz is supported.

### 3.16. Universal serial bus full-speed interface (USBFS)

- One USB device/host/OTG full-speed Interface with frequency up to 12 Mbit/s
- Internal 48 MHz oscillator support crystal-less operation
- Internal main PLL for USB CLK compliantly
- Internal USBFS PHY support

The Universal Serial Bus (USB) is a 4-wire bus with 4 bidirectional endpoints. The device controller enables 12 Mbit/s data exchange with integrated transceivers. Transaction formatting is performed by the hardware, including CRC generation and checking. It supports both host and device modes, as well as OTG mode with Host Negotiation Protocol (HNP) and Session Request Protocol (SRP). The controller contains a full-speed USB PHY internal. For full-speed or low-speed operation, no more external PHY chip is needed. It supports all the four types of transfer (control, bulk, Interrupt and isochronous) defined in USB 2.0 protocol. The required precise 48 MHz clock which can be generated from the internal main PLL (the clock source must use an HXTAL crystal oscillator) or by the internal 48 MHz oscillator in automatic trimming mode that allows crystal-less operation.

### 3.17. Universal serial bus high-speed interface (USBHS)

- One USB device/host/OTG high-speed Interface with frequency up to 480 Mbit/s
- An external PHY device connected to the ULPI is required when using in HS mode

USBHS supports both host and device modes, as well as OTG mode with Host Negotiation Protocol (HNP) and Session Request Protocol (SRP). The controller provides ULPI interface for external USB PHY integration and it also contains a full-speed USB PHY internal. For full-speed or low-speed operation, no more external PHY chip is needed. It supports all the four types of transfer (control, bulk, Interrupt and isochronous) defined in USB 2.0 protocol. HUB connection is supported when USBHS operates at high-speed in host mode. There is also a DMA engine operating as an AHB bus master in USBHS to speed up the data transfer between USBHS and system.

### 3.18. Controller area network (CAN)

- Two CAN2.0B interface with communication frequency up to 1 Mbit/s
- Internal main PLL for CAN CLK compliantly

Controller area network (CAN) is a method for enabling serial communication in field bus. The CAN protocol has been used extensively in industrial automation and automotive applications. It can receive and transmit standard frames with 11-bit identifiers as well as extended frames with 29-bit identifiers. Each CAN has three mailboxes for transmission and two FIFOs of three message deep for reception. It also provides 28 scalable/configurable identifier filter banks for selecting the incoming messages needed and discarding the others.

### 3.19. Ethernet (ENET)

- IEEE 802.3 compliant media access controller (MAC) for Ethernet LAN
- 10/100 Mbit/s rates with dedicated DMA controller and SRAM
- Support hardware precision time protocol (PTP) with conformity to IEEE 1588

The Ethernet media access controller (MAC) conforms to IEEE 802.3 specifications and fully supports IEEE 1588 standards. The embedded MAC provides the interface to the required external network physical interface (PHY) for LAN bus connection via an internal media independent interface (MII) or a reduced media independent interface (RMII). The number of MII signals provided up to 16 with 25 MHz output and RMII up to 7 with 50 MHz output. The function of 32-bit CRC checking is also available.

### 3.20. External memory controller (EXMC)

- Supported external memory: SRAM, PSRAM, ROM and NOR-Flash, NAND Flash and

CF card, SDRAM with up to 32-bit data bus

- Provide ECC calculating hardware module for NAND Flash memory block
- Two SDRAM banks with independent configuration, up to 13-bits Row Address, 11-bits Column Address, 2-bits internal banks address
- SDRAM Memory size: 4x16Mx32bit (256 MB), 4x16Mx16bit (128 MB), 4x16Mx8bit (64 MB)

External memory controller (EXMC) is an abbreviation of external memory controller. It is divided in to several sub-banks for external device support, each sub-bank has its own chip selection signal but at one time, only one bank can be accessed. The EXMC supports code execution from external memory except NAND Flash and CF card. The EXMC also can be configured to interface with the most common LCD module of Motorola 6800 and Intel 8080 series and reduce the system cost and complexity.

The EXMC of GD32F450xx in LQFP144 & BGA176 package also supports synchronous dynamic random access memory (SDRAM). It translates AHB transactions into the appropriate SDRAM protocol, and meanwhile, makes sure the access time requirements of the external SDRAM devices are satisfied.

### 3.21. Secure digital input and output card interface (SDIO)

- Support SD2.0/SDIO2.0/MMC4.2 host interface

The Secure Digital Input and Output Card Interface (SDIO) provides access to external SD memory cards specifications version 2.0, SDIO card specification version 2.0 and multi-media card system specification version 4.2 with DMA supported. In addition, this interface is also compliant with CE-ATA digital protocol rev1.1.

### 3.22. TFT LCD interface (TLI)

- 24-bit RGB Parallel Pixel Output; 8 bits-per-pixel (RGB888)
- Supports up to XVGA (1024x768) resolution
- 2 display layers with dedicated FIFO (64x32-bit)

The TFT LCD interface provides a parallel digital RGB (Red, Green and Blue) and signals for horizontal, vertical synchronization, Pixel Clock and Data Enable as output to interface directly to a variety of LCD (Liquid Crystal Display) and TFT (Thin Film Transistor) panels. A built-in DMA engine continuously move data from system memory to TLI and then, output to an external LCD display. Two separate layers are supported in TLI, as well as layer window and blending function.

### 3.23. Image processing accelerator (IPA)

- Copy one source image to the destination image

- Convert one source image to the destination image with specific pixel format
- Convert and blend two source images to the destination image with specific pixel format
- Fill up the destination image with a specific color

The Image processing accelerator (IPA) provides a configurable and flexible image format conversion from one or two source image to the destination image. Eleven pixel formats from 4-bit up to 32-bit per pixel independently for the two source images and five pixel formats from 16-bit up to 32-bit per pixel for the destination image are supported. Two 256\*32 bits Look-Up Tables (LUT) separately for the two source images are implemented for the indirect pixel formats.

### 3.24. Digital camera interface (DCI)

- Digital video/picture capture
- 8/10/12/14 data width supported
- High transfer efficiency with DMA interface
- Video/picture crop supported
- Various pixel formats supported including JPEG/YCrCb/RGB
- Hard/embedded synchronous signals supported

DCI is an 8-bit to 14-bit parallel interface that able to capture video or picture from a camera via Digital Camera Interface. It supports 8/10/12/14 bits data width through DMA operation.

### 3.25. Debug mode

- Serial wire JTAG debug port (SWJ-DP)

The Arm® SWJ-DP Interface is embedded and is a combined JTAG and serial wire debug port that enables either a serial wire debug or a JTAG probe to be connected to the target.

### 3.26. Package and operation temperature

- BGA176 (GD32F450Ix), LQFP144 (GD32F450Zx) and LQFP100 (GD32F450Vx)
- Operation temperature range: -40°C to +85°C (industrial level) for grade 6 devices, and -40°C to +105°C (industrial level) for grade 7 devices.

## 4. Electrical characteristics

### 4.1. Absolute maximum ratings

The maximum ratings are the limits to which the device can be subjected without permanently damaging the device. Note that the device is not guaranteed to operate properly at the maximum ratings. Exposure to the absolute maximum rating conditions for extended periods may affect device reliability.

**Table 4-1. Absolute maximum ratings<sup>(1)(4)</sup>**

Symbol	Parameter	Min	Max	Unit
V <sub>DD</sub>	External voltage range <sup>(2)</sup>	V <sub>SS</sub> - 0.3	V <sub>SS</sub> + 3.6	V
V <sub>DDA</sub>	External analog supply voltage	V <sub>SSA</sub> - 0.3	V <sub>SSA</sub> + 3.6	V
V <sub>BAT</sub>	External battery supply voltage	V <sub>SS</sub> - 0.3	V <sub>SS</sub> + 3.6	V
V <sub>IN</sub>	Input voltage on 5V tolerant pin <sup>(3)</sup>	V <sub>SS</sub> - 0.3	V <sub>DD</sub> + 3.6	V
	Input voltage on other I/O	V <sub>SS</sub> - 0.3	3.6	V
ΔV <sub>DDX</sub>	Variations between different VDD power pins	—	50	mV
V <sub>SSX</sub> - V <sub>SS</sub>	Variations between different ground pins	—	50	mV
I <sub>IO</sub>	Maximum current for GPIO pins	—	±25	mA
T <sub>A</sub>	Operating temperature range	-40	+85	°C
P <sub>D</sub>	Power dissipation at T <sub>A</sub> = 85°C of BGA176 <sup>(5)</sup>	—	888	mW
	Power dissipation at T <sub>A</sub> = 85°C of LQFP144 <sup>(5)</sup>	—	820	
	Power dissipation at T <sub>A</sub> = 85°C of LQFP100 <sup>(5)</sup>	—	697	
	Power dissipation at T <sub>A</sub> = 105°C of LQFP100 <sup>(5)</sup>	—	348	
T <sub>STG</sub>	Storage temperature range	-65	+150	°C
T <sub>J</sub>	Maximum junction temperature	—	125	°C

(1) Guaranteed by design, not tested in production.

(2) All main power and ground pins should be connected to an external power source within the allowable range.

(3) V<sub>IN</sub> maximum value cannot exceed 5.5 V.

(4) It is recommended that V<sub>DD</sub> and V<sub>DDA</sub> are powered by the same source. The maximum difference between V<sub>DD</sub> and V<sub>DDA</sub> does not exceed 300 mV during power-up and operation.

(5) For grade 6 devices, the parameter of T<sub>A</sub>=85°C, For grade 7 devices, the parameter of T<sub>A</sub>=105°C.

### 4.2. Recommended DC characteristics

**Table 4-2. DC operating conditions**

Symbol	Parameter	Conditions	Min <sup>(1)</sup>	Typ	Max <sup>(1)</sup>	Unit
V <sub>DD</sub>	Supply voltage	—	2.6	3.3	3.6	V
V <sub>DDA</sub>	Analog supply voltage	Same as V <sub>DD</sub>	2.6	3.3	3.6	V
V <sub>BAT</sub> <sup>(3)</sup>	Battery supply voltage	—	1.8 <sup>(2)</sup>	—	3.6	V
V <sub>core</sub>	Core logic supply voltage powered by internal voltage regulator	LDOVS[1:0]=01	—	1.14	—	V
		LDOVS[1:0]=10	—	1.26	—	

Symbol	Parameter	Conditions	Min <sup>(1)</sup>	Typ	Max <sup>(1)</sup>	Unit
		LDOVS[1:0]=11	—	1.32	—	

- (1) Based on characterization, not tested in production.
- (2) In the application which V<sub>BAT</sub> supply the backup domains, if the V<sub>BAT</sub> voltage drops below the minimum value, when V<sub>DD</sub> is powered on again, it is necessary to refresh the registers of backup domains and enable LXTAL again.
- (3) When both V<sub>DD</sub> and V<sub>BAT</sub> are powered simultaneously, it is required that V<sub>BAT</sub> ≤ V<sub>DD</sub> + 0.3 V.

Figure 4-1. Recommended power supply decoupling capacitors<sup>(1)(2)</sup>

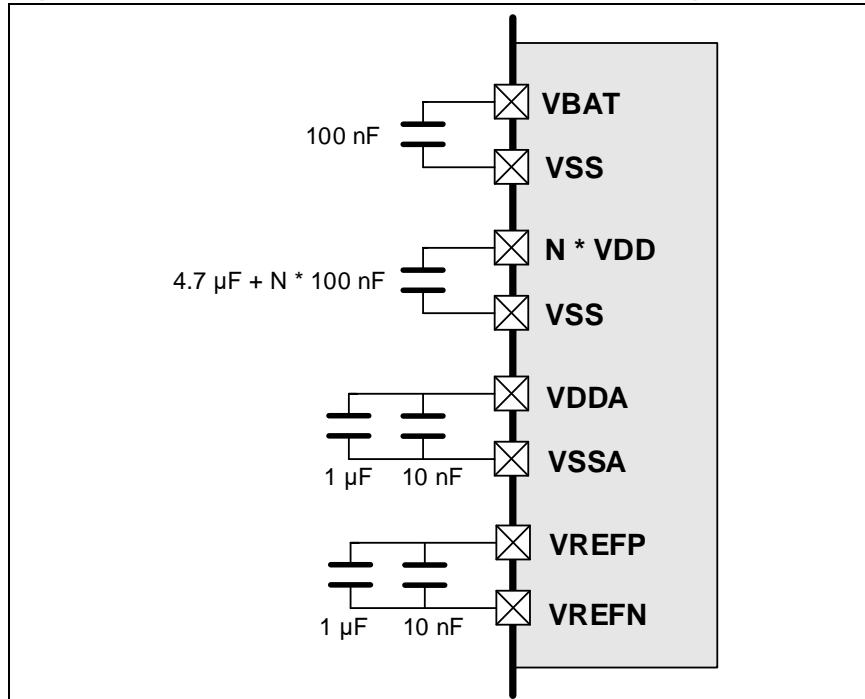

- (1) The VREFP and VREFN pins are only available on no less than 100-pin packages, or else the VREFP and VREFN pins are not available and internally connected to V<sub>DDA</sub> and V<sub>SSA</sub> pins. More details refer to **AN056 GD32F4xx Hardware Development Guide**.
- (2) All decoupling capacitors need to be as close as possible to the pins on the PCB board.

Table 4-3. Clock frequency<sup>(1)</sup>

Symbol	Parameter	Conditions	Min	Max	Unit
f <sub>HCLK</sub>	AHB clock frequency	—	—	200	MHz
f <sub>APB1</sub>	APB1 clock frequency	—	—	50	MHz
f <sub>APB2</sub>	APB2 clock frequency	—	—	100	MHz

- (1) Guaranteed by design, not tested in production.

Table 4-4. Operating conditions at Power up / Power down<sup>(1)</sup>

Symbol	Parameter	Conditions	Min	Max	Unit
t <sub>VDD</sub>	V <sub>DD</sub> rise time rate	—	0	∞	μs/V
	V <sub>DD</sub> fall time rate		20	∞	

- (1) Guaranteed by design, not tested in production.

Table 4-5. Start-up timings of Operating conditions<sup>(1)(2)(3)</sup>

Symbol	Parameter	Conditions	Min	Typ	Max	Unit
t <sub>start-up</sub>	Start-up time	Code area in FLASH = 256 kB	65	70	75	ms

		Code area in FLASH = 512 kB	130	140	150	
--	--	-----------------------------	-----	-----	-----	--

- (1) Guaranteed by design, not tested in production.
- (2) After power-up, the start-up time is the time between the rising edge of NRST high and the first I/O instruction conversion in SystemInit function.
- (3) PLL is off.

**Table 4-6. Power saving mode wakeup timings characteristics<sup>(1)</sup>**

Symbol	Parameter	Min	Typ	Max	Unit	
$t_{\text{Sleep}}^{(2)}$	Wakeup from Sleep mode	—	1.5	—	$\mu\text{s}$	
$t_{\text{Deep-sleep}}^{(2)}$	Wakeup from Deep-sleep mode (LDO On)	—	3.3	—		
	Wakeup from Deep-sleep mode (LDO in low power mode)	—	3.3	—		
$t_{\text{Standby}}^{(3)}$	Wakeup from Standby mode	Code area in FLASH = 256 kB	65	70	75	ms
		Code area in FLASH = 512 kB	130	140	150	

- (1) The wakeup time is measured from the wakeup event to the point at which the application code reads the first instruction under the below conditions:  $V_{\text{DD}} = V_{\text{DDA}} = 3.3 \text{ V}$ , IRC16M = System clock = 16 MHz.
- (2) Based on characterization, not tested in production.
- (3) Guaranteed by design, not tested in production.

### 4.3. Power consumption

The power measurements specified in the tables represent that code with data executing from on-chip Flash with the following specifications.

**Table 4-7. Power consumption characteristics<sup>(2)(3)(4)(5)(6)</sup>**

Symbol	Parameter	Conditions	Min	Typ <sup>(1)</sup>	Max	Unit
$I_{\text{DD}}+I_{\text{DDA}}$	Supply current (Run mode)	$V_{\text{DD}} = V_{\text{DDA}} = 3.3 \text{ V}$ , HXTAL = 25 MHz, System clock = 200 MHz, All peripherals enabled	—	98.12	—	mA
		$V_{\text{DD}} = V_{\text{DDA}} = 3.3 \text{ V}$ , HXTAL = 25 MHz, System clock = 200 MHz, All peripherals disabled	—	59.74	—	mA
		$V_{\text{DD}} = V_{\text{DDA}} = 3.3 \text{ V}$ , HXTAL = 25 MHz, System clock = 180 MHz, All peripherals enabled	—	88.74	—	mA
		$V_{\text{DD}} = V_{\text{DDA}} = 3.3 \text{ V}$ , HXTAL = 25 MHz, System clock = 180 MHz, All peripherals disabled	—	54.12	—	mA
		$V_{\text{DD}} = V_{\text{DDA}} = 3.3 \text{ V}$ , HXTAL = 25 MHz, System clock = 120 MHz, All peripherals enabled	—	60.74	—	mA

Symbol	Parameter	Conditions	Min	Typ <sup>(1)</sup>	Max	Unit
		V <sub>DD</sub> = V <sub>DDA</sub> = 3.3 V, HXTAL = 25 MHz, System clock = 120 MHz, All peripherals disabled	—	37.34	—	mA
		V <sub>DD</sub> = V <sub>DDA</sub> = 3.3 V, HXTAL = 25 MHz, System clock = 108 MHz, All peripherals enabled	—	55.36	—	mA
		V <sub>DD</sub> = V <sub>DDA</sub> = 3.3 V, HXTAL = 25 MHz, System clock = 108 MHz, All peripherals disabled	—	34.76	—	mA
		V <sub>DD</sub> = V <sub>DDA</sub> = 3.3 V, HXTAL = 25 MHz, System clock = 90 MHz, All peripherals enabled	—	46.22	—	mA
		V <sub>DD</sub> = V <sub>DDA</sub> = 3.3 V, HXTAL = 25 MHz, System clock = 90 MHz, All peripherals disabled	—	29.52	—	mA
		V <sub>DD</sub> = V <sub>DDA</sub> = 3.3 V, HXTAL = 25 MHz, System clock = 60 MHz, All peripherals enabled	—	31.98	—	mA
		V <sub>DD</sub> = V <sub>DDA</sub> = 3.3 V, HXTAL = 25 MHz, System clock = 60 MHz, All peripherals disabled	—	20.64	—	mA
		V <sub>DD</sub> = V <sub>DDA</sub> = 3.3 V, HXTAL = 25 MHz, System clock = 30 MHz, All peripherals enabled	—	18.06	—	mA
		V <sub>DD</sub> = V <sub>DDA</sub> = 3.3 V, HXTAL = 25 MHz, System clock = 30 MHz, All peripherals disabled	—	12.16	—	mA
		V <sub>DD</sub> = V <sub>DDA</sub> = 3.3 V, IRC16M = 16 MHz, System clock = 25 MHz, All peripherals enabled	—	14.40	—	mA
		V <sub>DD</sub> = V <sub>DDA</sub> = 3.3 V, IRC16M = 16 MHz, System clock = 25 MHz, All peripherals disabled	—	9.48	—	mA
		V <sub>DD</sub> = V <sub>DDA</sub> = 3.3 V, IRC16M = 16 MHz, System clock = 16 MHz, All peripherals enabled	—	10.10	—	mA
		V <sub>DD</sub> = V <sub>DDA</sub> = 3.3 V, IRC16M = 16 MHz, System clock = 16 MHz, All peripherals disabled	—	6.96	—	mA
		V <sub>DD</sub> = V <sub>DDA</sub> = 3.3 V, IRC16M = 16 MHz, System clock = 8 MHz, All peripherals enabled	—	6.38	—	mA

Symbol	Parameter	Conditions	Min	Typ <sup>(1)</sup>	Max	Unit
		V <sub>DD</sub> = V <sub>DDA</sub> = 3.3 V, IRC16M = 16 MHz, System clock = 8 MHz, All peripherals disabled	—	4.78	—	mA
		V <sub>DD</sub> = V <sub>DDA</sub> = 3.3 V, IRC16M = 16 MHz, System clock = 4 MHz, All peripherals enabled	—	4.28	—	mA
		V <sub>DD</sub> = V <sub>DDA</sub> = 3.3 V, IRC16M = 16 MHz, System clock = 4 MHz, All peripherals disabled	—	3.50	—	mA
		V <sub>DD</sub> = V <sub>DDA</sub> = 3.3 V, IRC16M = 16 MHz, System clock = 2 MHz, All peripherals enabled	—	3.40	—	mA
		V <sub>DD</sub> = V <sub>DDA</sub> = 3.3 V, IRC16M = 16 MHz, System clock = 2 MHz, All peripherals disabled	—	2.99	—	mA
	Supply current (Sleep mode)	V <sub>DD</sub> = V <sub>DDA</sub> = 3.3 V, HXTAL = 25 MHz, System clock = 200 MHz, CPU clock off, All peripherals enabled	—	66.50	—	mA
		V <sub>DD</sub> = V <sub>DDA</sub> = 3.3 V, HXTAL = 25 MHz, System clock = 200 MHz, CPU clock off, All peripherals disabled	—	28.96	—	mA
		V <sub>DD</sub> = V <sub>DDA</sub> = 3.3 V, HXTAL = 25 MHz, System clock = 180 MHz, CPU clock off, All peripherals enabled	—	60.26	—	mA
		V <sub>DD</sub> = V <sub>DDA</sub> = 3.3 V, HXTAL = 25 MHz, System clock = 180 MHz, CPU clock off, All peripherals disabled	—	26.32	—	mA
		V <sub>DD</sub> = V <sub>DDA</sub> = 3.3 V, HXTAL = 25 MHz, System clock = 120 MHz, CPU clock off, All peripherals enabled	—	41.64	—	mA
		V <sub>DD</sub> = V <sub>DDA</sub> = 3.3 V, HXTAL = 25 MHz, System clock = 120 MHz, CPU clock off, All peripherals disabled	—	18.72	—	mA
		V <sub>DD</sub> = V <sub>DDA</sub> = 3.3 V, HXTAL = 25 MHz, System clock = 108 MHz, CPU clock off, All peripherals enabled	—	38.58	—	mA
		V <sub>DD</sub> = V <sub>DDA</sub> = 3.3 V, HXTAL = 25 MHz, System clock = 108 MHz, CPU clock off, All peripherals disabled	—	17.96	—	mA
		V <sub>DD</sub> = V <sub>DDA</sub> = 3.3 V, HXTAL = 25 MHz, System clock = 90 MHz, CPU clock off, All peripherals enabled	—	31.94	—	mA

Symbol	Parameter	Conditions	Min	Typ <sup>(1)</sup>	Max	Unit
		V <sub>DD</sub> = V <sub>DDA</sub> = 3.3 V, HXTAL = 25 MHz, System clock = 90 MHz, CPU clock off, All peripherals disabled	—	14.94	—	mA
		V <sub>DD</sub> = V <sub>DDA</sub> = 3.3 V, HXTAL = 25 MHz, System clock = 60 MHz, CPU clock off, All peripherals enabled	—	22.48	—	mA
		V <sub>DD</sub> = V <sub>DDA</sub> = 3.3 V, HXTAL = 25 MHz, System clock = 60 MHz, CPU clock off, All peripherals disabled	—	11.16	—	mA
		V <sub>DD</sub> = V <sub>DDA</sub> = 3.3 V, HXTAL = 25 MHz, System clock = 30 MHz, CPU clock off, All peripherals enabled	—	13.34	—	mA
		V <sub>DD</sub> = V <sub>DDA</sub> = 3.3 V, HXTAL = 25 MHz, System clock = 30 MHz, CPU clock off, All peripherals disabled	—	7.58	—	mA
		V <sub>DD</sub> = V <sub>DDA</sub> = 3.3 V, IRC16M = 16 MHz, System clock = 25 MHz, CPU clock off, All peripherals enabled	—	10.52	—	mA
		V <sub>DD</sub> = V <sub>DDA</sub> = 3.3 V, IRC16M = 16 MHz, System clock = 25 MHz, CPU clock off, All peripherals disabled	—	5.70	—	mA
		V <sub>DD</sub> = V <sub>DDA</sub> = 3.3 V, IRC16M = 16 MHz, System clock = 16 MHz, CPU clock off, All peripherals enabled	—	7.58	—	mA
		V <sub>DD</sub> = V <sub>DDA</sub> = 3.3 V, IRC16M = 16 MHz, System clock = 16 MHz, CPU clock off, All peripherals disabled	—	4.54	—	mA
		V <sub>DD</sub> = V <sub>DDA</sub> = 3.3 V, IRC16M = 16 MHz, System clock = 8 MHz, CPU clock off, All peripherals enabled	—	5.18	—	mA
		V <sub>DD</sub> = V <sub>DDA</sub> = 3.3 V, IRC16M = 16 MHz, System clock = 8 MHz, CPU clock off, All peripherals disabled	—	3.58	—	mA
		V <sub>DD</sub> = V <sub>DDA</sub> = 3.3 V, IRC16M = 16 MHz, System clock = 4 MHz, CPU clock off, All peripherals enabled	—	3.78	—	mA
		V <sub>DD</sub> = V <sub>DDA</sub> = 3.3 V, IRC16M = 16 MHz, System clock = 4 MHz, CPU clock off, All peripherals disabled	—	3.00	—	mA
		V <sub>DD</sub> = V <sub>DDA</sub> = 3.3 V, IRC16M = 16 MHz, System clock = 2 MHz, CPU clock off, All peripherals enabled	—	3.14	—	mA

Symbol	Parameter	Conditions	Min	Typ <sup>(1)</sup>	Max	Unit
		V <sub>DD</sub> = V <sub>DDA</sub> = 3.3 V, IRC16M = 16 MHz, System clock = 2 MHz, CPU clock off, All peripherals disabled	—	2.74	—	mA
	Supply current (Deep-Sleep mode)	V <sub>DD</sub> = V <sub>DDA</sub> = 3.3 V, LDO in normal power and normal driver mode, IRC32K off	—	1.21	11	mA
		V <sub>DD</sub> = V <sub>DDA</sub> = 3.3 V, LDO in normal power and low driver mode, IRC32K off, RTC off	—	1.18	11	mA
		V <sub>DD</sub> = V <sub>DDA</sub> = 3.3 V, LDO in low power and normal driver mode, IRC32K off, RTC off	—	0.83	11	mA
		V <sub>DD</sub> = V <sub>DDA</sub> = 3.3 V, LDO in low power and low driver mode, IRC32K off, RTC off	—	0.80	11	mA
	Supply current (Standby mode)	V <sub>DD</sub> = V <sub>DDA</sub> = 3.3 V, LXTAL off, IRC32K on, RTC on SRAM ON	—	6.84	16.5	μA
		V <sub>DD</sub> = V <sub>DDA</sub> = 3.3 V, LXTAL off, IRC32K on, RTC off SRAM ON	—	6.50	16.5	μA
		V <sub>DD</sub> = V <sub>DDA</sub> = 3.3 V, LXTAL off, IRC32K off, RTC off SRAM ON	—	5.92	16.5	μA
		V <sub>DD</sub> = V <sub>DDA</sub> = 3.3 V, LXTAL off, IRC32K on, RTC on SRAM OFF	—	5.22	16.5	μA
		V <sub>DD</sub> = V <sub>DDA</sub> = 3.3 V, LXTAL off, IRC32K on, RTC off SRAM OFF	—	4.87	16.5	μA
		V <sub>DD</sub> = V <sub>DDA</sub> = 3.3 V, LXTAL off, IRC32K off, RTC off SRAM OFF	—	4.30	16.5	μA
I <sub>BAT</sub>	Battery supply current (Backup mode)	V <sub>DD</sub> off, V <sub>DDA</sub> off, V <sub>BAT</sub> = 3.6 V, LXTAL on with external crystal, RTC on, LXTAL High driving SRAM ON	—	3.84	—	μA
		V <sub>DD</sub> off, V <sub>DDA</sub> off, V <sub>BAT</sub> = 3.3 V, LXTAL on with external crystal, RTC on, LXTAL High driving SRAM ON	—	3.46	—	μA
		V <sub>DD</sub> off, V <sub>DDA</sub> off, V <sub>BAT</sub> = 2.6 V, LXTAL on with external crystal, RTC on, LXTAL High driving SRAM ON	—	3.26	—	μA
		V <sub>DD</sub> off, V <sub>DDA</sub> off, V <sub>BAT</sub> = 3.6 V, LXTAL on with external crystal, RTC on, LXTAL High driving SRAM OFF	—	1.99	—	μA
		V <sub>DD</sub> off, V <sub>DDA</sub> off, V <sub>BAT</sub> = 3.3 V, LXTAL on with external crystal, RTC on, LXTAL High driving SRAM OFF	—	1.82	—	μA
		V <sub>DD</sub> off, V <sub>DDA</sub> off, V <sub>BAT</sub> = 2.6 V, LXTAL on with external crystal, RTC on, LXTAL High driving, SRAM OFF	—	1.52	—	μA

Symbol	Parameter	Conditions	Min	Typ <sup>(1)</sup>	Max	Unit
		V <sub>DD</sub> off, V <sub>DDA</sub> off, V <sub>BAT</sub> = 3.6 V, LXTAL on with external crystal, RTC on, LXTAL Low driving, SRAM ON	—	3.20	—	μA
		V <sub>DD</sub> off, V <sub>DDA</sub> off, V <sub>BAT</sub> = 3.3 V, LXTAL on with external crystal, RTC on, LXTAL Low driving, SRAM ON	—	2.90	—	μA
		V <sub>DD</sub> off, V <sub>DDA</sub> off, V <sub>BAT</sub> = 2.6 V, LXTAL on with external crystal, RTC on, LXTAL Low driving, SRAM ON	—	2.65	—	μA
		V <sub>DD</sub> off, V <sub>DDA</sub> off, V <sub>BAT</sub> = 3.6 V, LXTAL on with external crystal, RTC on, LXTAL Low driving, SRAM OFF	—	1.36	—	μA
		V <sub>DD</sub> off, V <sub>DDA</sub> off, V <sub>BAT</sub> = 3.3 V, LXTAL on with external crystal, RTC on, LXTAL Low driving, SRAM OFF	—	1.25	—	μA
		V <sub>DD</sub> off, V <sub>DDA</sub> off, V <sub>BAT</sub> = 2.6 V, LXTAL on with external crystal, RTC on, LXTAL Low driving, SRAM OFF	—	0.91	—	μA
		V <sub>DD</sub> off, V <sub>DDA</sub> off, V <sub>BAT</sub> = 3.6 V, LXTAL off with external crystal, RTC off, SRAM ON	—	1.98	—	μA
		V <sub>DD</sub> off, V <sub>DDA</sub> off, V <sub>BAT</sub> = 3.3 V, LXTAL off with external crystal, RTC off, SRAM ON	—	1.82	—	μA
		V <sub>DD</sub> off, V <sub>DDA</sub> off, V <sub>BAT</sub> = 2.6 V, LXTAL off with external crystal, RTC off, SRAM ON	—	1.75	—	μA
		V <sub>DD</sub> off, V <sub>DDA</sub> off, V <sub>BAT</sub> = 3.6 V, LXTAL off with external crystal, RTC off, SRAM OFF	—	0.13	—	μA
		V <sub>DD</sub> off, V <sub>DDA</sub> off, V <sub>BAT</sub> = 3.3 V, LXTAL off with external crystal, RTC off, SRAM OFF	—	0.04	—	μA
		V <sub>DD</sub> off, V <sub>DDA</sub> off, V <sub>BAT</sub> = 2.6 V, LXTAL off with external crystal, RTC off, SRAM OFF	—	0	—	μA

- (1) Based on characterization, not tested in production.
- (2) Unless otherwise specified, all values given for T<sub>A</sub> = 25 °C and test result is mean value.
- (3) When System Clock is less than 4 MHz, an external source is used, and the HXTAL bypass function is needed, no PLL.
- (4) When System Clock is greater than 8 MHz, a crystal 8 MHz is used, and the HXTAL bypass function is closed, using PLL.
- (5) When analog peripheral blocks such as ADCs, DACs, HXTAL, LXTAL, IRC16M, or IRC32K are ON, an additional power consumption should be considered.
- (6) All GPIOs are configured as analog mode except standby mode.

Figure 4-2. Typical supply current consumption in Run mode

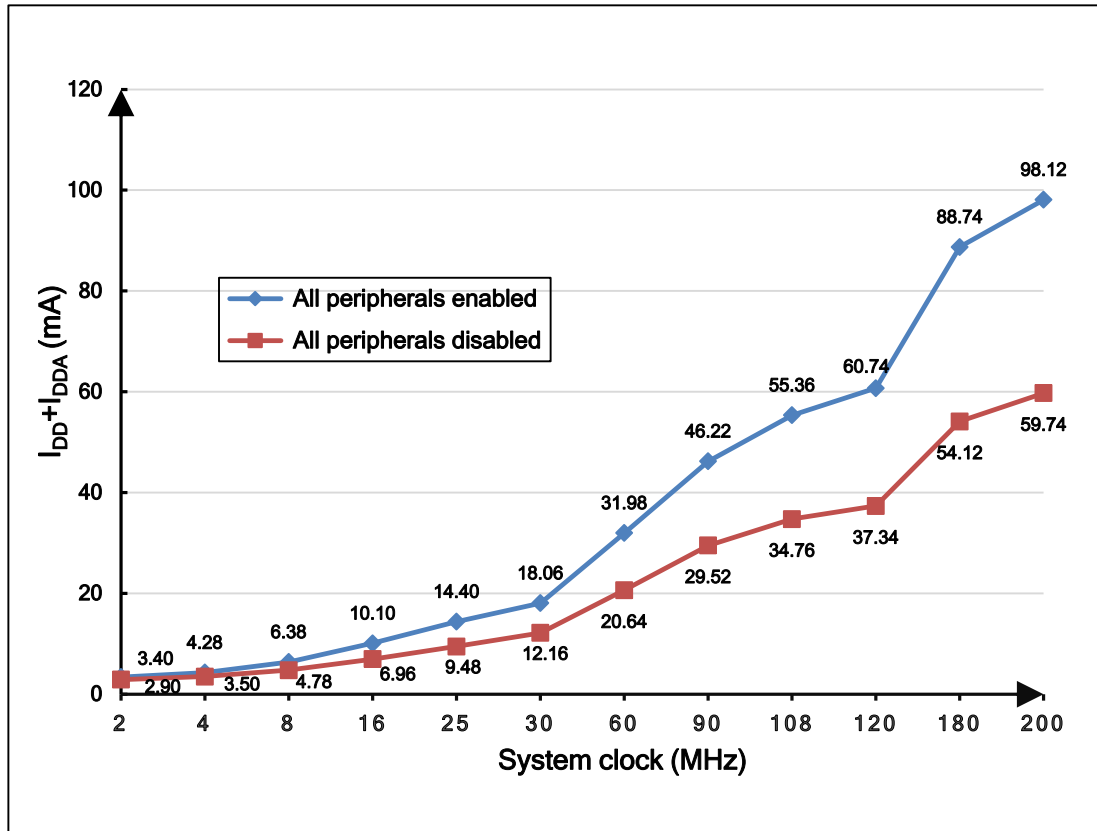

Figure 4-3. Typical supply current consumption in Sleep mode

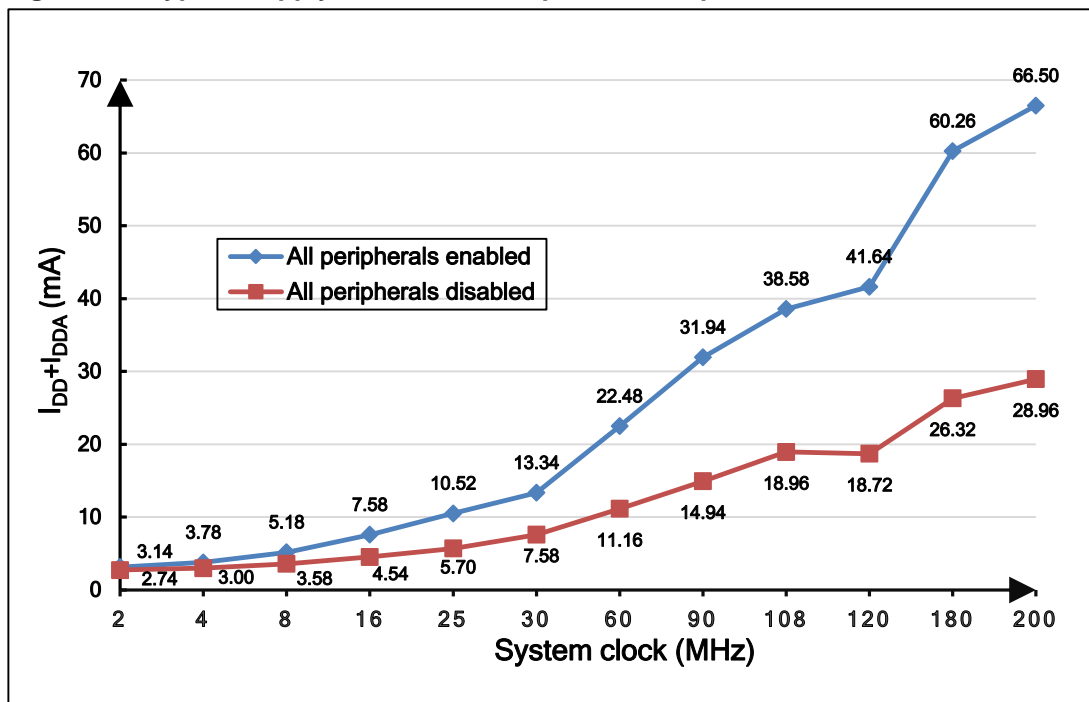

Table 4-8. Peripheral current consumption characteristics<sup>(1)</sup>

Peripherals <sup>(5)</sup>		Typical consumption at T <sub>A</sub> = 25 °C (TYP)	Unit
AHB1	USB_ULPI + USB_HS	4.5	mA
	ETH_MAC + ETH_MAC_TX + ETH_MAC_RX + ETH_MAC_PTP	6.66	
	IPA	1.89	
	DMA1	3.32	
	DMA0	3.36	
	TCMSRAM	1.04	
	BKPSRAM	0.92	
	CRC	0.45	
	GPIOA	0.57	
	GPIOB	0.59	
	GPIOC	0.57	
	GPIOD	0.58	
	GPIOE	0.61	
	GPIOF	0.59	
	GPIOG	0.60	
	GPIOH	0.60	
	GPIOI	0.57	
AHB2	USB_FS	3.33	
	TRNG	1.01	
	DCI	1.25	
AHB3	EXMC	4.29	
APB1	UART7	0.87	
	UART6	0.06	
	DAC1+DAC2 <sup>(2)</sup>	5.35	
	PMU	0.3	
	CAN1	0.26	
	CAN0	0.3	
	I2C2	0.16	
	I2C1	0.17	
	I2C0	0.18	
	UART4	0.13	
	UART3	0.1	
	USART2	0.19	
	USART1	0.17	
	SPI2/I2S2 <sup>(3)</sup>	0.06/0.12	
	SPI1/I2S1 <sup>(3)</sup>	0.06/0.16	
	WWDG	0.92	
	TIMER13	0.92	
TIMER12	1.01		

	TIMER11	1.02
	TIMER6	0.79
	TIMER5	0.77
	TIMER4	1.25
	TIMER3	1.15
	TIMER2	1.14
	TIMER1	1.24
APB2	TLI	0.77
	SPI5	0.03
	SPI4	0.03
	TIMER10	0.64
	TIMER9	0.63
	TIMER8	0.69
	SYSCFG	0.02
	SPI3	0.06
	SPI0	0.9
	SDIO	1.5
	ADC2 <sup>(4)</sup>	1.26
	ADC1 <sup>(4)</sup>	1.28
	ADC0 <sup>(4)</sup>	1.68
	USART5	1.17
	USART0	1.06
TIMER7	2.23	
TIMER0	2.19	
ADDAPB1	IREF	0.43
	CTC	0.93

- (1) Based on characterization, not tested in production.
- (2) DEN0 and DEN1 bits in the DAC\_CTL register are set to 1, and the converted value set to 0x800.
- (3) Enable SPIx CLKEN, I2SSEL bit and I2SEN bit set to 1 in SPI\_I2SCTL.
- (4) System clock =  $f_{HCLK} = 200$  MHz,  $f_{APB1} = f_{HCLK}/4$ ,  $f_{APB2} = f_{HCLK}/2$ ,  $f_{ADCCLK} = f_{APB2}/4$ , ADON bit is set to 1.
- (5) If there is no other description, then  $VDD = V_{DDA} = 3.3$  V,  $HXTAL = 25$  MHz, system clock =  $f_{HCLK} = 200$  MHz,  $f_{APB1} = f_{HCLK}/4$ ,  $f_{APB2} = f_{HCLK}/2$ .

#### 4.4. EMC characteristics

EMS (electromagnetic susceptibility) includes ESD (Electrostatic discharge, positive and negative) and FTB (Burst of Fast Transient voltage, positive and negative) testing result is given in [Table 4-9. EMS characteristics<sup>\(1\)</sup>](#), based on the EMS levels and classes compliant with IEC 61000 series standard.

**Table 4-9. EMS characteristics<sup>(1)</sup>**

Symbol	Parameter	Conditions	Level/Class
V <sub>ESD</sub>	Voltage applied to all device pins to induce a functional disturbance	V <sub>DD</sub> = 3.3 V, T <sub>A</sub> = 25 °C LQFP144, f <sub>HCLK</sub> = 168 MHz conforms to IEC 61000-4-2	3A
V <sub>FTB</sub>	Fast transient voltage burst applied to induce a functional disturbance through 100 pF on VDD and VSS pins	V <sub>DD</sub> = 3.3 V, T <sub>A</sub> = 25 °C LQFP144, f <sub>HCLK</sub> = 168 MHz conforms to IEC 61000-4-4	3A

(1) Based on characterization, not tested in production.

EMI (Electromagnetic Interference) emission test result is given in the [Table 4-10. EMI characteristics<sup>\(1\)</sup>](#). The electromagnetic field emitted by the device are monitored while an application, executing EEMBC code, is running. The test is compliant with SAE J1752-3:2017 standard which specifies the test board and the pin loading.

**Table 4-10. EMI characteristics<sup>(1)</sup>**

Symbol	Parameter	Conditions	Tested frequency band	Max vs. [f <sub>HXTAL</sub> /f <sub>HCLK</sub> ]	Unit
				25/200 MHz	
S <sub>EMI</sub>	Peak level	V <sub>DD</sub> = 3.6 V, T <sub>A</sub> = +25 °C, LQFP144, f <sub>HCLK</sub> = 200 MHz, conforms to SAE J1752-3:2017	0.15 MHz to 30 MHz	3.42	dBμV
			30 MHz to 130 MHz	10.41	
			130 MHz to 1 GHz	12.91	

(1) Based on characterization, not tested in production.

## 4.5. Power supply supervisor characteristics

**Table 4-11. Power supply supervisor characteristics**

Symbol	Parameter	Conditions	Min	Typ	Max	Unit
V <sub>LVD</sub> <sup>(1)</sup>	Low voltage Detector level selection	LVDT<2:0> = 000(rising edge)	—	2.15	—	V
		LVDT<2:0> = 000(falling edge)	—	2.04	—	
		LVDT<2:0> = 001(rising edge)	—	2.28	—	
		LVDT<2:0> = 001(falling edge)	—	2.17	—	
		LVDT<2:0> = 010(rising edge)	—	2.43	—	
		LVDT<2:0> = 010(falling edge)	—	2.31	—	
		LVDT<2:0> = 011(rising edge)	—	2.56	—	
		LVDT<2:0> = 011(falling edge)	—	2.45	—	
		LVDT<2:0> = 100(rising edge)	—	2.7	—	
		LVDT<2:0> = 100(falling edge)	—	2.59	—	

Symbol	Parameter	Conditions	Min	Typ	Max	Unit
		LVDT<2:0> = 101(rising edge)	—	2.84	—	
		LVDT<2:0> = 101(falling edge)	—	2.73	—	
		LVDT<2:0> = 110(rising edge)	—	2.98	—	
		LVDT<2:0> = 110(falling edge)	—	2.87	—	
		LVDT<2:0> = 111(rising edge)	—	3.12	—	
		LVDT<2:0> = 111(falling edge)	—	3.01	—	
V <sub>LVDhyst</sub> <sup>(2)</sup>	LVD hysteresis	—	—	100	—	mV
V <sub>POR</sub> <sup>(1)</sup>	Power on reset threshold	—	—	2.40	—	V
V <sub>PDR</sub> <sup>(1)</sup>	Power down reset threshold	—	—	1.80	—	V
V <sub>PDRhyst</sub> <sup>(2)</sup>	PDR hysteresis	—	—	600	—	mV
V <sub>BOR3</sub> <sup>(2)</sup>	Brownout level 3 threshold	Falling edge	—	2.79	—	V
		Rising edge	—	2.88	—	V
V <sub>BOR2</sub> <sup>(2)</sup>	Brownout level 2 threshold	Falling edge	—	2.49	—	V
		Rising edge	—	2.58	—	V
V <sub>BOR1</sub> <sup>(2)</sup>	Brownout level 1 threshold	Falling edge	—	2.19	—	V
		Rising edge	—	2.29	—	V
V <sub>BORhyst</sub> <sup>(2)</sup>	BOR hysteresis	—	—	100	—	mV
t <sub>RSTTEMPO</sub> <sup>(2)</sup>	Reset temporization	—	—	2	—	ms

(1) Based on characterization, not tested in production.

(2) Guaranteed by design, not tested in production.

**Figure 4-4. Recommended PDR\_ON pin circuit**

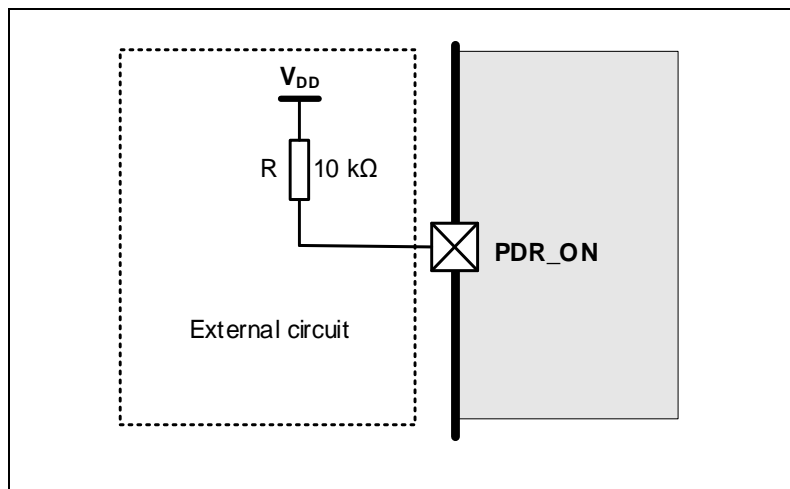

(1) The PDR supervisor can be enabled/disabled through PDR\_ON pin.

- (2) When PDR\_ON pin is connected to VSS (Internal Reset OFF), the VBAT functionality is no more available and VBAT pin should be connected to VDD.
- (3) The PDR\_ON pin must be kept at high level. The user can flexibly adjust the value of the pull-up resistor R according to the specific scenario for a better performance.

## 4.6. Electrical sensitivity

The device is strained in order to determine its performance in terms of electrical sensitivity. Electrostatic discharges (ESD) are applied directly to the pins of the sample. Static latch-up (LU) test is based on the two measurement methods.

**Table 4-12. ESD characteristics<sup>(1)</sup>**

Symbol	Parameter	Conditions	Min	Typ	Max	Unit
$V_{ESD(HBM)}$	Electrostatic discharge voltage (human body model)	$T_A = 25\text{ }^\circ\text{C}$ ; JS-001-2014	—	—	7000	V
$V_{ESD(CDM)}$	Electrostatic discharge voltage (charge device model)	$T_A = 25\text{ }^\circ\text{C}$ ; JS-002-2014	—	—	800	V

(1) Based on characterization, not tested in production.

**Table 4-13. Static latch-up characteristics<sup>(1)</sup>**

Symbol	Parameter	Conditions	Min	Typ	Max	Unit
LU	I-test	$T_A = 25\text{ }^\circ\text{C}$ ; JESD78	—	—	$\pm 200$	mA
	$V_{\text{supply over voltage}}$		—	—	5.4	V

(1) Based on characterization, not tested in production.

## 4.7. External clock characteristics

**Table 4-14. High speed external clock (HXTAL) generated from a crystal/ceramic characteristics**

Symbol	Parameter	Conditions	Min	Typ	Max	Unit
$f_{HXTAL}^{(1)}$	Crystal or ceramic frequency	$2.6\text{ V} \leq V_{DD} \leq 3.6\text{ V}$	4	8	32	MHz
$R_F^{(2)}$	Feedback resistor	$V_{DD} = 3.3\text{ V}$	—	400	—	k $\Omega$
$C_{HXTAL}^{(2)(3)}$	Recommended matching capacitance on OSCIN and OSCOUT	—	—	20	30	pF
$D_{\text{cyc}}^{(HXTAL)(2)}$	Crystal or ceramic duty cycle	—	30	50	70	%
$g_m^{(2)}$	Oscillator transconductance	Startup	—	25	—	mA/V
$I_{DDHXTAL}^{(1)}$	Crystal or ceramic operating current	$V_{DD} = 3.3\text{ V}$ , $f_{HCLK} = f_{IRC16M} = 16\text{ MHz}$	—	1	—	mA
$t_{SUHXTAL}^{(1)}$	Crystal or ceramic startup time	$V_{DD} = 3.3\text{ V}$ , $f_{HCLK} = f_{IRC16M} = 16\text{ MHz}$	—	1.8	—	ms

(1) Based on characterization, not tested in production.

- (2) Guaranteed by design, not tested in production.
- (3)  $C_{\text{HXTAL1}} = C_{\text{HXTAL2}} = 2 \cdot (C_{\text{LOAD}} - C_{\text{S}})$ , For  $C_{\text{HXTAL1}}$  and  $C_{\text{HXTAL2}}$ , it is recommended matching capacitance on OSCIN and OSCOUT. For  $C_{\text{LOAD}}$ , it is crystal/ceramic load capacitance, provided by the crystal or ceramic manufacturer. For  $C_{\text{S}}$ , it is PCB and MCU pin stray capacitance.

**Table 4-15. High speed external clock characteristics (HXTAL in bypass mode)**

Symbol	Parameter	Conditions	Min	Typ	Max	Unit
$f_{\text{HXTAL\_ext}}^{(1)}$	External clock source or oscillator frequency	$2.6 \text{ V} \leq V_{\text{DD}} \leq 3.6 \text{ V}$	1	—	50	MHz
$V_{\text{HXTALH}}^{(2)}$	OSCIN input pin high level voltage	$V_{\text{DD}} = 3.3 \text{ V}$	$0.7 V_{\text{DD}}$	—	$V_{\text{DD}}$	V
$V_{\text{HXTALL}}^{(2)}$	OSCIN input pin low level voltage		$V_{\text{SS}}$	—	$0.3 V_{\text{DD}}$	V
$t_{\text{H/L(HXTAL)}}^{(2)}$	OSCIN high or low time	—	5	—	—	ns
$t_{\text{R/F(HXTAL)}}^{(2)}$	OSCIN rise or fall time	—	—	—	10	ns
$C_{\text{IN}}^{(2)}$	OSCIN input capacitance	—	—	5	—	pF
$\text{Ducy}_{(\text{HXTAL})}^{(2)}$	Duty cycle	—	40	—	60	%

(1) Based on characterization, not tested in production.

(2) Guaranteed by design, not tested in production.

**Table 4-16. Low speed external clock (LXTAL) generated from a crystal/ceramic characteristics**

Symbol	Parameter	Conditions	Min	Typ	Max	Unit
$f_{\text{LXTAL}}^{(1)}$	Crystal or ceramic frequency	$V_{\text{DD}} = 3.3 \text{ V}$	—	32.768	—	kHz
$C_{\text{LXTAL}}^{(2)(3)}$	Recommended matching capacitance on OSC32IN and OSC32OUT	—	—	15	—	pF
$\text{Ducy}_{(\text{LXTAL})}^{(2)}$	Crystal or ceramic duty cycle	—	30	—	70	%
$g_{\text{m}}^{(2)}$	Oscillator transconductance	Medium low driving capability	—	6	—	$\mu\text{A/V}$
		Higher driving capability	—	18	—	
$I_{\text{DDLXTAL}}^{(1)}$	Crystal or ceramic operating current	LXTALDRI = 0	—	0.9	—	$\mu\text{A}$
		LXTALDRI = 1	—	1.5	—	
$t_{\text{SULXTAL}}^{(1)(4)}$	Crystal or ceramic startup time	—	—	1.8	—	s

(1) Based on characterization, not tested in production.

(2) Guaranteed by design, not tested in production.

(3)  $C_{\text{LXTAL1}} = C_{\text{LXTAL2}} = 2 \cdot (C_{\text{LOAD}} - C_{\text{S}})$ , For  $C_{\text{LXTAL1}}$  and  $C_{\text{LXTAL2}}$ , it is recommended matching capacitance on OSC32IN and OSC32OUT. For  $C_{\text{LOAD}}$ , it is crystal/ceramic load capacitance, provided by the crystal or ceramic manufacturer. For  $C_{\text{S}}$ , it is PCB and MCU pin stray capacitance.

(4)  $t_{\text{SULXTAL}}$  is the startup time measured from the moment it is enabled (by software) to the 32.768 kHz oscillator stabilization flags is SET. This value varies significantly with the crystal manufacturer.

**Table 4-17. Low speed external user clock characteristics (LXTAL in bypass mode)**

Symbol	Parameter	Conditions	Min	Typ	Max	Unit
$f_{LXTAL\_ext}^{(1)}$	External clock source or oscillator frequency	$V_{DD} = 3.3\text{ V}$	—	32.768	1000	kHz
$V_{LXTALH}^{(2)}$	OSC32IN input pin high level voltage	—	0.7 $V_{DD}$	—	$V_{DD}$	V
$V_{LXTALL}^{(2)}$	OSC32IN input pin low level voltage	—	$V_{SS}$	—	0.3 $V_{DD}$	
$t_{H/L(LXTAL)}^{(2)}$	OSC32IN high or low time	—	450	—	—	ns
$t_{R/F(LXTAL)}^{(2)}$	OSC32IN rise or fall time	—	—	—	50	
$C_{IN}^{(2)}$	OSC32IN input capacitance	—	—	5	—	pF
$Ducy_{(LXTAL)}^{(2)}$	Duty cycle	—	30	50	70	%

(1) Based on characterization, not tested in production.

(2) Guaranteed by design, not tested in production.

## 4.8. Internal clock characteristics

**Table 4-18. High speed internal clock (IRC16M) characteristics**

Symbol	Parameter	Conditions	Min	Typ	Max	Unit
$f_{IRC16M}$	High Speed Internal Oscillator (IRC16M) frequency	$V_{DD} = V_{DDA} = 3.3\text{ V}$	—	16	—	MHz
$ACC_{IRC16M}$	IRC16M oscillator Frequency accuracy, Factory-trimmed	$V_{DD} = V_{DDA} = 3.3\text{ V}$ , $T_A = -40\text{ °C} \sim +85\text{ °C}^{(1)}$	-4.0	—	+5.0	%
		$V_{DD} = V_{DDA} = 3.3\text{ V}$ , $T_A = 0\text{ °C} \sim +85\text{ °C}^{(1)}$	-2.0	—	+2.0	%
		$V_{DD} = V_{DDA} = 3.3\text{ V}$ , $T_A = 25\text{ °C}$	-1.0	—	+1.0	%
	IRC16M oscillator Frequency accuracy, User trimming step <sup>(1)</sup>	—	—	0.5	—	%
$Ducy_{IRC16M}^{(2)}$	IRC16M oscillator duty cycle	$V_{DD} = V_{DDA} = 3.3\text{ V}$	45	50	55	%
$I_{DDAIRC16M}^{(1)}$	IRC16M oscillator operating current	$V_{DD} = V_{DDA} = 3.3\text{ V}$ , $f_{HCLK} = f_{HXTAL\_PLL} = 200\text{ MHz}$	—	66	80	$\mu\text{A}$
$t_{SUIRC16M}^{(1)}$	IRC16M oscillator startup time	$V_{DD} = V_{DDA} = 3.3\text{ V}$ , $f_{HCLK} = f_{HXTAL\_PLL} = 200\text{ MHz}$	—	2.5	4	$\mu\text{s}$

(1) Based on characterization, not tested in production.

(2) Guaranteed by design, not tested in production.

**Table 4-19. High speed internal clock (IRC48M) characteristics**

Symbol	Parameter	Conditions	Min	Typ	Max	Unit
$f_{IRC48M}$	High Speed Internal Oscillator (IRC48M) frequency	$V_{DD} = 3.3\text{ V}$	—	48	—	MHz
ACCIRC48M	IRC48M oscillator Frequency accuracy, Factory-trimmed	$V_{DD} = V_{DDA} = 3.3\text{ V}$ , $T_A = -40\text{ }^\circ\text{C} \sim +85\text{ }^\circ\text{C}^{(1)}$	-4.0	—	+5.0	%
		$V_{DD} = V_{DDA} = 3.3\text{ V}$ , $T_A = 0\text{ }^\circ\text{C} \sim +85\text{ }^\circ\text{C}^{(1)}$	-3.0	—	+3.0	%
		$V_{DD} = V_{DDA} = 3.3\text{ V}$ , $T_A = 25\text{ }^\circ\text{C}$	-2.0	—	+2.0	%
	IRC48M oscillator Frequency accuracy, User trimming step <sup>(1)</sup>	—	—	0.12	—	%
$D_{IRC48M}^{(2)}$	IRC48M oscillator duty cycle	$V_{DD} = V_{DDA} = 3.3\text{ V}$	45	50	55	%
$I_{DDAIRC48M}^{(1)}$	IRC48M oscillator operating current	$V_{DD} = V_{DDA} = 3.3\text{ V}$ , $f_{HCLK} = f_{HXTAL\_PLL} = 200\text{ MHz}$	—	240	300	$\mu\text{A}$
$t_{SUIRC48M}^{(1)}$	IRC48M oscillator startup time	$V_{DD} = V_{DDA} = 3.3\text{ V}$ , $f_{HCLK} = f_{HXTAL\_PLL} = 200\text{ MHz}$	—	2.5	4	$\mu\text{s}$

(1) Based on characterization, not tested in production.

(2) Guaranteed by design, not tested in production.

**Table 4-20. Low speed internal clock (IRC32K) characteristics**

Symbol	Parameter	Conditions	Min	Typ	Max	Unit
$f_{IRC32K}^{(1)}$	Low Speed Internal oscillator (IRC32K) frequency	$V_{DD} = V_{DDA} = 3.3\text{ V}$ , $T_A = -40\text{ }^\circ\text{C} \sim +85\text{ }^\circ\text{C}$	—	32	—	kHz
$I_{DDAIRC32K}^{(2)}$	IRC32K oscillator operating current	$V_{DD} = V_{DDA} = 3.3\text{ V}$ , $f_{HCLK} = f_{HXTAL\_PLL} = 200\text{ MHz}$	—	0.4	0.6	$\mu\text{A}$
$t_{SUIRC32K}^{(2)}$	IRC32K oscillator startup time	$V_{DD} = V_{DDA} = 3.3\text{ V}$ , $f_{HCLK} = f_{HXTAL\_PLL} = 200\text{ MHz}$	—	110	150	$\mu\text{s}$

(1) Guaranteed by design, not tested in production.

(2) Based on characterization, not tested in production.

## 4.9. PLL characteristics

**Table 4-21. PLL characteristics**

Symbol	Parameter	Conditions	Min	Typ	Max	Unit
$f_{PLLIN}^{(1)}$	PLL input clock frequency	—	1	—	4	MHz
$f_{PLLOUT}^{(2)}$	PLL output clock frequency	—	32	—	250	MHz
$f_{VCO}^{(2)}$	PLL VCO output clock frequency	—	64	—	500	MHz
$t_{LOCK}^{(2)}$	PLL lock time	VCO freq = 100 MHz	—	80	168	$\mu\text{s}$
		VCO freq = 500 MHz	—	100	300	

$I_{DDA}^{(1)(3)}$	Current consumption on $V_{DDA}$	VCO freq = 500 MHz	—	1100	—	$\mu A$
Jitter <sub>PLL</sub>	Cycle to cycle Jitter(rms)	System clock	—	40	—	ps
	Cycle to cycle Jitter (peak to peak)		—	400	—	

- (1) Based on characterization, not tested in production.  
 (2) Guaranteed by design, not tested in production.  
 (3) System clock = IRC16M = 16 MHz, PLL clock source = IRC16M/2 = 8 MHz,  $f_{PLLOUT}$  = 200 MHz.  
 (4) Value given with main PLL running.

**Table 4-22. PLLI2S characteristics**

Symbol	Parameter	Conditions	Min	Typ	Max	Unit
$f_{PLLIN}^{(1)}$	PLLI2S input clock frequency	—	1	—	4	MHz
$f_{PLLOUT}^{(2)}$	PLLI2S output clock frequency	—	32	—	250	MHz
$f_{VCO}^{(2)}$	PLLI2S VCO output clock frequency	—	64	—	500	MHz
$t_{LOCK}^{(2)}$	PLLI2S lock time	VCO freq = 100 MHz	—	80	168	$\mu s$
		VCO freq = 500 MHz	—	100	300	
$I_{DDA}^{(1)(3)}$	Current consumption on $V_{DDA}$	VCO freq = 500 MHz	—	1100	—	$\mu A$
Jitter <sub>PLL</sub>	Cycle to cycle Jitter(rms)	System clock	—	40	—	ps
	Cycle to cycle Jitter (peak to peak)		—	400	—	

- (1) Based on characterization, not tested in production.  
 (2) Guaranteed by design, not tested in production.  
 (3) System clock = IRC16M = 16 MHz, PLL clock source = IRC16M/2 = 8 MHz,  $f_{PLLOUT}$  = 200 MHz.  
 (4) Value given with main PLLI2S running.

**Table 4-23. PLLSAI characteristics**

Symbol	Parameter	Conditions	Min	Typ	Max	Unit
$f_{PLLIN}^{(1)}$	PLLSAI input clock frequency	—	1	—	4	MHz
$f_{PLLOUT}^{(2)}$	PLLSAI output clock frequency	—	32	—	250	MHz
$f_{VCO}^{(2)}$	PLLSAI VCO output clock frequency	—	64	—	500	MHz
$t_{LOCK}^{(2)}$	PLLSAI lock time	VCO freq = 100 MHz	—	80	168	$\mu s$
		VCO freq = 500 MHz	—	100	300	
$I_{DDA}^{(1)(3)}$	Current consumption on $V_{DDA}$	VCO freq = 500 MHz	—	1100	—	$\mu A$
Jitter <sub>PLL</sub>	Cycle to cycle Jitter(rms)	System clock	—	40	—	ps
	Cycle to cycle Jitter (peak to peak)		—	400	—	

- (1) Based on characterization, not tested in production.

- (2) Guaranteed by design, not tested in production.  
 (3) System clock = IRC16M = 16 MHz, PLL clock source = IRC16M/2 = 8 MHz,  $f_{PLLOUT} = 200$  MHz.  
 (4) Value given with main PLLSAI running.

**Table 4-24. PLL spread spectrum clock generation (SSCG) characteristics**

Symbol	Parameter	Conditions	Min	Typ	Max	Unit
$F_{MOD}$	Modulation frequency	—	—	—	10	KHz
Mdamp	Peak modulation amplitude	—	—	—	2	%
MODCNT*	—	—	—	—	$2^{15}-1$	—
MODSTEP	—	—	—	—	—	—

- (1) Based on characterization, not tested in production.  
 (2) Guaranteed by design, not tested in production.

**Equation 1:** SSCG configuration equation:

$$MODCNT = \text{round}(f_{PLLIN}/4/f_{mod})$$

$$MODSTEP = \text{round}(mdamp * PLLN * 2^{14}/(MODCNT * 100))$$

The formula above (Equation 1) is SSCG configuration equation.

## 4.10. Memory characteristics

**Table 4-25. Flash memory characteristics<sup>(1)</sup>**

Symbol	Parameter	Conditions	Min	Typ	Max	Unit
$PE_{CYC}$	Number of guaranteed program /erase cycles before failure (Endurance)	$T_A = -40\text{ }^{\circ}\text{C} \sim +85\text{ }^{\circ}\text{C}$	100	—	—	kcycles
$t_{READ}$	Read time at code flash area	$T_A = -40\text{ }^{\circ}\text{C} \sim +85\text{ }^{\circ}\text{C}$	—	1	—	hclks
	Read time at data flash area		52	—	4172	
$t_{RET}$	Data retention time	—	—	20	—	years
$t_{PROG}$	Word programming time	$T_A = -40\text{ }^{\circ}\text{C} \sim +85\text{ }^{\circ}\text{C}$	—	37.5	180	$\mu\text{s}$
$t_{ERASE16kB}$	Sector(16kB) erase time	$T_A = -40\text{ }^{\circ}\text{C} \sim +85\text{ }^{\circ}\text{C}$	—	200	2000	ms
$t_{ERASE64kB}$	Sector(64kB) erase time		—	300	4000	
$t_{ERASE128kB}$	Sector(128kB) erase time		—	600	8000	
$t_{MERASE(512K)}$	Mass erase time	$T_A = -40\text{ }^{\circ}\text{C} \sim +85\text{ }^{\circ}\text{C}$	—	2.4	32	s
$t_{MERASE(1MB)}$	Mass erase time	$T_A = -40\text{ }^{\circ}\text{C} \sim +85\text{ }^{\circ}\text{C}$	—	4.8	64	s
$t_{MERASE(2MB)}$	Mass erase time	$T_A = -40\text{ }^{\circ}\text{C} \sim +85\text{ }^{\circ}\text{C}$	—	9.6	128	s
$t_{MERASE(3MB)}$	Mass erase time	$T_A = -40\text{ }^{\circ}\text{C} \sim +85\text{ }^{\circ}\text{C}$	—	14.4	192	s

- (1) Guaranteed by design and/or characterization, not 100% tested in production.

## 4.11. NRST pin characteristics

**Table 4-26. NRST pin characteristics**

Symbol	Parameter	Conditions	Min	Typ	Max	Unit
$V_{L(NRST)}^{(1)}$	NRST Input low level voltage	$V_{DD} = V_{DDA} = 2.6\text{ V}$	-0.3	—	$0.3 V_{DD}$	V
$V_{IH(NRST)}^{(1)}$	NRST Input high level voltage		$0.7 V_{DD}$	—	$V_{DD} + 0.3$	
$V_{hyst}^{(1)}$	Schmidt trigger Voltage hysteresis		—	360	—	mV

Symbol	Parameter	Conditions	Min	Typ	Max	Unit
$V_{IL(NRST)}^{(1)}$	NRST Input low level voltage	$V_{DD} = V_{DDA} = 3.3\text{ V}$	-0.3	—	$0.3 V_{DD}$	V
$V_{IH(NRST)}^{(1)}$	NRST Input high level voltage		$0.7 V_{DD}$	—	$V_{DD} + 0.3$	
$V_{hyst}^{(1)}$	Schmidt trigger Voltage hysteresis		—	420	—	
$V_{IL(NRST)}^{(1)}$	NRST Input low level voltage	$V_{DD} = V_{DDA} = 3.6\text{ V}$	-0.3	—	$0.3 V_{DD}$	V
$V_{IH(NRST)}^{(1)}$	NRST Input high level voltage		$0.7 V_{DD}$	—	$V_{DD} + 0.3$	
$V_{hyst}^{(1)}$	Schmidt trigger Voltage hysteresis		—	440	—	
$R_{pu}^{(2)}$	Pull-up equivalent resistor	—	—	40	—	k $\Omega$

- (1) Based on characterization, not tested in production.  
 (2) Guaranteed by design, not tested in production.

Figure 4-5. Recommended external NRST pin circuit<sup>(1)</sup>

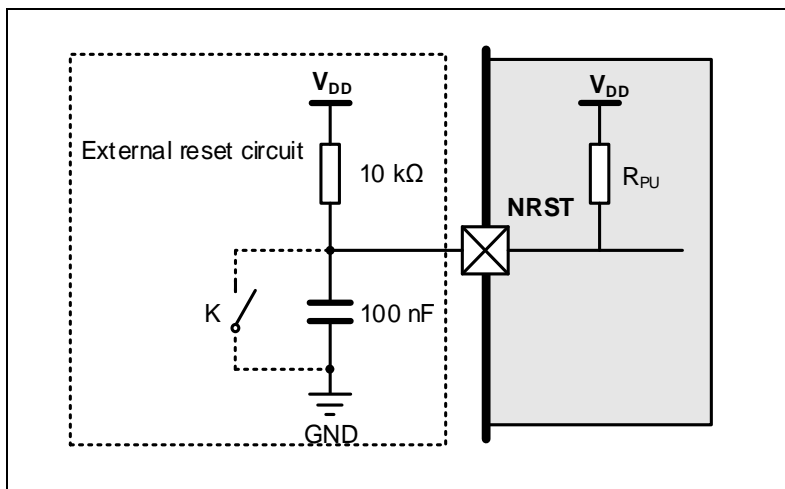

- (1) Unless the voltage on NRST pin go below  $V_{IL(NRST)}$  level, the device would not generate a reliable reset.

## 4.12. GPIO characteristics

Table 4-27. I/O port DC characteristics<sup>(1)(3)</sup>

Symbol	Parameter	Conditions	Min	Typ	Max	Unit
$V_{IL}$	Standard IO Low level input voltage	$2.6\text{ V} \leq V_{DD} = V_{DDA} \leq 3.6\text{ V}$	—	—	$0.3 V_{DD}$	V
	5V-tolerant IO Low level input voltage	$2.6\text{ V} \leq V_{DD} = V_{DDA} \leq 3.6\text{ V}$	—	—	$0.3 V_{DD}$	V
$V_{IH}$	Standard IO High level input voltage	$2.6\text{ V} \leq V_{DD} = V_{DDA} \leq 3.6\text{ V}$	$0.7 V_{DD}$	—	—	V
	5V-tolerant IO High level input voltage	$2.6\text{ V} \leq V_{DD} = V_{DDA} \leq 3.6\text{ V}$	$0.7 V_{DD}$	—	—	V
$V_{OL}$	Low level output voltage for an IO Pin ( $I_{IO} = +8\text{ mA}$ )	$V_{DD} = 2.6\text{ V}$	—	—	0.2	V
		$V_{DD} = 3.3\text{ V}$	—	—	0.2	
		$V_{DD} = 3.6\text{ V}$	—	—	0.2	
$V_{OL}$	Low level output voltage for an IO Pin ( $I_{IO} = +20\text{ mA}$ )	$V_{DD} = 2.6\text{ V}$	—	—	0.46	V
		$V_{DD} = 3.3\text{ V}$	—	—	0.40	
		$V_{DD} = 3.6\text{ V}$	—	—	0.40	

V <sub>OH</sub>	High level output voltage for an IO Pin (I <sub>IO</sub> = +8 mA)		V <sub>DD</sub> = 2.6 V	2.38	—	—	V
			V <sub>DD</sub> = 3.3 V	3.1	—	—	
			V <sub>DD</sub> = 3.6 V	3.4	—	—	
V <sub>OH</sub>	High level output voltage for an IO Pin (I <sub>IO</sub> = +20 mA)		V <sub>DD</sub> = 2.6 V	2.05	—	—	V
			V <sub>DD</sub> = 3.3 V	2.84	—	—	
			V <sub>DD</sub> = 3.6 V	3.12	—	—	
R <sub>PU</sub> <sup>(2)</sup>	Internal pull-up resistor	All pins	V <sub>IN</sub> = V <sub>SS</sub>	30	40	50	kΩ
		PA10	—	7.5	10	13.5	
R <sub>PD</sub> <sup>(2)</sup>	Internal pull- down resistor	All pins	V <sub>IN</sub> = V <sub>DD</sub>	30	40	50	kΩ
		PA10	—	7.5	10	13.5	

- (1) Based on characterization, not tested in production.
- (2) Guaranteed by design, not tested in production.
- (3) All pins except PC13 / PC14 / PC15 / PI8. Since PC13 to PC15 and PI8 are supplied through the Power Switch, which can only be obtained by a small current( typical source capability:3mA shared between these IOs, but sink capability is same as other IO) , the speed of GPIOs PC13 to PC15 and PI8 should not exceed 2 MHz when they are in output mode(maximum load: 30 pF).

**Table 4-28. I/O port AC characteristics<sup>(1)(2)</sup>**

GPIOx_OSPD[1:0] bit value <sup>(3)</sup>	Parameter	Conditions	Max	Unit
GPIOx_OSPD0->OSPDy[1:0] = 00 (IO_Speed = 2 MHz)	Maximum frequency <sup>(4)</sup>	V <sub>DD</sub> = 3.3 V, C <sub>L</sub> = 10 pF	30	MHz
		V <sub>DD</sub> = 3.3 V, C <sub>L</sub> = 30 pF	25	
		V <sub>DD</sub> = 3.3 V, C <sub>L</sub> = 50 pF	15	
GPIOx_OSPD0->OSPDy[1:0] = 01 (IO_Speed = 25 MHz)	Maximum frequency <sup>(4)</sup>	V <sub>DD</sub> = 3.3 V, C <sub>L</sub> = 10 pF	95	MHz
		V <sub>DD</sub> = 3.3 V, C <sub>L</sub> = 30 pF	80	
		V <sub>DD</sub> = 3.3 V, C <sub>L</sub> = 50 pF	50	
GPIOx_OSPD0->OSPDy[1:0] = 10 (IO_Speed = 50 MHz)	Maximum frequency <sup>(4)</sup>	V <sub>DD</sub> = 3.3 V, C <sub>L</sub> = 10 pF	160	MHz
		V <sub>DD</sub> = 3.3 V, C <sub>L</sub> = 30 pF	125	
		V <sub>DD</sub> = 3.3 V, C <sub>L</sub> = 50 pF	90	
GPIOx_OSPD0->OSPDy[1:0] = 11 (IO_Speed = 200 MHz)	Maximum frequency <sup>(4)</sup>	V <sub>DD</sub> = 3.3 V, C <sub>L</sub> = 10 pF	200	MHz
		V <sub>DD</sub> = 3.3 V, C <sub>L</sub> = 30 pF	170	
		V <sub>DD</sub> = 3.3 V, C <sub>L</sub> = 50 pF	130	

- (1) Based on characterization, not tested in production.
- (2) Unless otherwise specified, all test results given for T<sub>A</sub> = 25 °C.
- (3) The I/O speed is configured using the GPIOx\_OSPD -> OSPDy[1:0] bits. Refer to the GD32F4xx user manual which is selected to set the GPIO port output speed.
- (4) The maximum frequency is defined in Figure 4-6, and maximum frequency cannot exceed 200 MHz.

**Figure 4-6. I/O port AC characteristics definition**

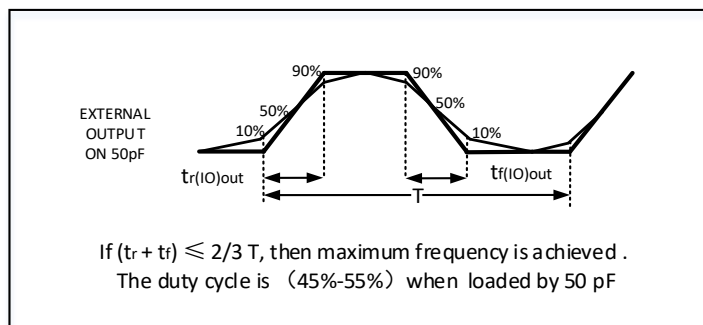

## 4.13. ADC characteristics

**Table 4-29. ADC characteristics**

Symbol	Parameter	Conditions	Min	Typ	Max	Unit
V <sub>DDA</sub> <sup>(1)</sup>	Operating voltage	—	2.6	3.3	3.6	V
V <sub>IN</sub> <sup>(1)</sup>	ADC input voltage range	—	0	—	V <sub>REFP</sub>	V
V <sub>REFP</sub> <sup>(2)(3)</sup>	Positive Reference Voltage	—	2.6	—	V <sub>DDA</sub>	V
V <sub>REFN</sub> <sup>(2)</sup>	Negative Reference Voltage	—	—	V <sub>SSA</sub>	—	V
f <sub>ADC</sub> <sup>(1)</sup>	ADC clock	—	0.1	—	40	MHz
f <sub>s</sub> <sup>(1)</sup>	Sampling rate	12-bit	0.007	—	2.6	MSP
		10-bit	0.008	—	3.1	
		8-bit	0.01	—	3.6	S
		6-bit	0.011	—	4.4	
V <sub>AIN</sub> <sup>(1)</sup>	Analog input voltage	16 external; 3 internal	0	—	V <sub>DDA</sub>	V
R <sub>AIN</sub> <sup>(2)</sup>	External input impedance	See <a href="#">Equation 2</a>	—	—	52.1	kΩ
R <sub>ADC</sub> <sup>(2)</sup>	Input sampling switch resistance	—	—	—	0.55	kΩ
C <sub>ADC</sub> <sup>(2)</sup>	Input sampling capacitance	No pin/pad capacitance included	—	—	5.5	pF
t <sub>CAL</sub> <sup>(2)</sup>	Calibration time	f <sub>ADC</sub> = 40 MHz	—	3.275	—	μs
t <sub>s</sub> <sup>(2)</sup>	Sampling time	f <sub>ADC</sub> = 40 MHz	0.075	—	12	μs
t <sub>CONV</sub> <sup>(2)</sup>	Total conversion time (including sampling time)	12-bit	—	15	—	1/ f <sub>ADC</sub>
		10-bit	—	13	—	
		8-bit	—	11	—	
		6-bit	—	9	—	
t <sub>SU</sub> <sup>(2)</sup>	Startup time	—	—	—	1	μs

(1) Based on characterization, not tested in production.

(2) Guaranteed by design, not tested in production.

(3) V<sub>REFP</sub> should always be equal to or less than V<sub>DDA</sub>, especially during power up.

**Equation 2:** R<sub>AIN</sub> max formula 
$$R_{AIN} < \frac{T_s}{f_{ADC} \cdot C_{ADC} \cdot \ln(2^{N+2})} - R_{ADC}$$

The formula above (Equation 2) is used to determine the maximum external impedance allowed for an error below 1/4 of LSB. Here N = 12 (from 12-bit resolution).

**Table 4-30. ADC RAIN max for f<sub>ADC</sub> = 40 MHz<sup>(2)</sup>**

T <sub>s</sub> (cycles)	t <sub>s</sub> (us)	R <sub>AIN</sub> max (KΩ)
3	0.075	0.85
15	0.375	6.5
28	0.7	12.6
55	1.375	25.2
84	2.1	38.8
112	2.8	51.9
144	3.6	N/A

$T_s$ (cycles)	$t_s$ (us)	$R_{AIN\ max}$ (K $\Omega$ )
480	12	N/A

- (1) Based on characterization, not tested in production.  
 (2) Guaranteed by design, not tested in production.

**Table 4-31. ADC dynamic accuracy at  $f_{ADC} = 30\text{ MHz}^{(1)}$**

Symbol	Parameter	Test conditions	Min	Typ	Max	Unit
ENOB	Effective number of bits	$f_{ADC} = 30\text{ MHz}$	10.5	10.6	—	bits
SNDR	Signal-to-noise and distortion ratio	$V_{DDA} = V_{REFP} = 2.6\text{ V}$	65	65.6	—	dB
SNR	Signal-to-noise ratio	Input Frequency = 110 kHz	65.5	66	—	
THD	Total harmonic distortion	Temperature = 25 °C	-74	-76	—	

- (1) Based on characterization, not tested in production.  
 (2) Guaranteed by design, not tested in production.

**Table 4-32. ADC dynamic accuracy at  $f_{ADC} = 30\text{ MHz}^{(1)}$**

Symbol	Parameter	Test conditions	Min	Typ	Max	Unit
ENOB	Effective number of bits	$f_{ADC} = 30\text{ MHz}$	10.7	10.8	—	bits
SNDR	Signal-to-noise and distortion ratio	$V_{DDA} = V_{REFP} = 3.3\text{ V}$	66.2	65.8	—	dB
SNR	Signal-to-noise ratio	Input Frequency = 110 kHz	66.8	67.4	—	
THD	Total harmonic distortion	Temperature = 25 °C	-71	-75	—	

- (1) Based on characterization, not tested in production.  
 (2) Guaranteed by design, not tested in production.

**Table 4-33. ADC dynamic accuracy at  $f_{ADC} = 36\text{ MHz}^{(1)}$**

Symbol	Parameter	Test conditions	Min	Typ	Max	Unit
ENOB	Effective number of bits	$f_{ADC} = 36\text{ MHz}$	10.3	10.4	—	bits
SNDR	Signal-to-noise and distortion ratio	$V_{DDA} = V_{REFP} = 3.3\text{ V}$	63.8	64.4	—	dB
SNR	Signal-to-noise ratio	Input Frequency = 110 kHz	64.2	65	—	
THD	Total harmonic distortion	Temperature = 25 °C	-70	-72	—	

- (1) Based on characterization, not tested in production.  
 (2) Guaranteed by design, not tested in production.

**Table 4-34. ADC dynamic accuracy at  $f_{ADC} = 40\text{ MHz}^{(1)}$**

Symbol	Parameter	Test conditions	Min	Typ	Max	Unit
ENOB	Effective number of bits	$f_{ADC} = 40\text{ MHz}$	9.9	10.0	—	bits
SNDR	Signal-to-noise and distortion ratio	$V_{DDA} = V_{REFP} = 3.3\text{ V}$	61.4	62	—	dB
SNR	Signal-to-noise ratio	Input Frequency = 110 kHz	62	62.4	—	
THD	Total harmonic distortion	Temperature = 25 °C	-68	-70	—	

- (1) Based on characterization, not tested in production.  
 (2) Guaranteed by design, not tested in production.

**Table 4-35. ADC static accuracy at  $f_{ADC} = 15\text{ MHz}^{(1)}$**

Symbol	Parameter	Test conditions	Typ	Max	Unit
Offset	Offset error	$f_{ADC} = 15\text{ MHz}$	±2	±3	LSB

DNL	Differential linearity error	$V_{DDA} = V_{REFP} = 3.3\text{ V}$	$\pm 0.9$	$\pm 1.2$	
INL	Integral linearity error		$\pm 1.1$	$\pm 1.5$	

- (1) Based on characterization, not tested in production.  
(2) Guaranteed by design, not tested in production.

## 4.14. Temperature sensor characteristics

**Table 4-36. Temperature sensor characteristics<sup>(1)</sup>**

Symbol	Parameter	Min	Typ	Max	Unit
$T_L$	VSENSE linearity with temperature	—	$\pm 1.5$	—	$^{\circ}\text{C}$
Avg_Slope	Average slope	—	4.1	—	mV/ $^{\circ}\text{C}$
$V_{25}$	Voltage at 25 $^{\circ}\text{C}$	—	1.45	—	V
$t_{S\_temp}^{(2)}$	ADC sampling time when reading the temperature	—	17.1	—	$\mu\text{s}$

- (1) Based on characterization, not tested in production.  
(2) Shortest sampling time can be determined in the application by multiple iterations.

## 4.15. DAC characteristics

**Table 4-37. DAC characteristics**

Symbol	Parameter	Conditions	Min	Typ	Max	Unit
$V_{DDA}^{(1)}$	Operating voltage	—	2.6	3.3	3.6	V
$V_{REFP}^{(2)}$	Positive Reference Voltage	—	2.6	—	$V_{DDA}$	V
$V_{REFN}^{(2)}$	Negative Reference Voltage	—	—	$V_{SSA}$	—	V
$R_{LOAD}^{(2)}$	Resistive load	Resistive load with buffer ON	5	—	—	k $\Omega$
$R_o^{(2)}$	Impedance output	Impedance output with buffer OFF	—	—	15	k $\Omega$
$C_{LOAD}^{(2)}$	Capacitive load	Capacitive load with buffer ON	—	—	50	pF
$DAC\_OUT_{min}^{(2)}$	Lower DAC_OUT voltage	Lower DAC_OUT voltage with buffer ON	0.2	—	—	V
		Lower DAC_OUT voltage with buffer OFF	0.5	—	—	mV
$DAC\_OUT_{max}^{(2)}$	Higher DAC_OUT voltage	Higher DAC_OUT voltage with buffer ON	—	—	$V_{DDA} - 0.2$	V
		Higher DAC_OUT voltage with buffer OFF	—	—	$V_{DDA} - 1\text{LSB}$	V
$I_{DDA}^{(1)}$	DAC current consumption in quiescent mode	With no load, middle code(0x800) on the input, $V_{REFP} = 3.6\text{ V}$	—	—	500	$\mu\text{A}$
		With no load, worst code(0xF1C) on the input, $V_{REFP} = 3.6\text{ V}$	—	—	560	

IDDVREFP <sup>(1)</sup>	DAC current consumption in quiescent mode	With no load, middle code(0x800) on the input, V <sub>REFP</sub> = 3.6 V	—	86	—	μA
		With no load, worst code(0xF1C) on the input, V <sub>REFP</sub> = 3.6 V	—	298	—	
DNL <sup>(1)</sup>	Differential non linearity	10-bit configuration	—	—	±0.5	LSB
		12-bit configuration	—	—	±2	
INL <sup>(1)</sup>	Integral non linearity	10-bit configuration	—	—	±1	LSB
		12-bit configuration	—	—	±4	
Offset <sup>(1)</sup>	Offset error	DAC in 12-bit mode	—	—	±12	LSB
GE <sup>(1)</sup>	Gain error	DAC in 12-bit mode	—	±0.5	—	%
T <sub>setting</sub> <sup>(1)</sup>	Settling time	C <sub>LOAD</sub> ≤ 50 pF, R <sub>LOAD</sub> ≥ 5 kΩ	—	0.5	1	μs
T <sub>wakeup</sub> <sup>(2)</sup>	Wakeup from off state	—	—	5	10	μs
Update rate <sup>(2)</sup>	Max frequency for a correct DAC_OUT change from code i to i±1LSB	C <sub>LOAD</sub> ≤ 50 pF, R <sub>LOAD</sub> ≥ 5 kΩ	—	—	4	MS/s
PSRR <sup>(2)</sup>	Power supply rejection ratio(to V <sub>DDA</sub> )	No R <sub>Load</sub> , C <sub>LOAD</sub> =50 pF	—	-90	-75	dB

(1) Based on characterization, not tested in production.

(2) Guaranteed by design, not tested in production.

## 4.16. I2C characteristics

Table 4-38. I2C characteristics<sup>(1)(2)</sup>

Symbol	Parameter	Conditions	Standard mode		Fast mode		Unit
			Min	Max	Min	Max	
t <sub>SCL(H)</sub>	SCL clock high time	—	4.0	—	0.6	—	μs
t <sub>SCL(L)</sub>	SCL clock low time	—	4.7	—	1.3	—	μs
t <sub>SU(SDA)</sub>	SDA setup time	—	250	—	100	—	ns
t <sub>h(SDA)</sub>	SDA data hold time	—	0 <sup>(3)</sup>	3450	0	900	ns
t <sub>r(SDA/SCL)</sub>	SDA and SCL rise time	—	—	1000	—	300	ns
t <sub>f(SDA/SCL)</sub>	SDA and SCL fall time	—	—	300	—	300	ns
t <sub>h(STA)</sub>	Start condition hold time	—	4.0	—	0.6	—	μs
t <sub>SU(STA)</sub>	Repeated Start condition setup time	—	4.7	—	0.6	—	μs
t <sub>SU(STO)</sub>	Stop condition setup time	—	4.0	—	0.6	—	μs
t <sub>buff</sub>	Stop to Start condition time (bus free)	—	4.7	—	1.3	—	μs

(1) Guaranteed by design, not tested in production.

(2) To ensure the standard mode I2C frequency, f<sub>PCLK1</sub> must be at least 2 MHz. To ensure the fast mode I2C frequency, f<sub>PCLK1</sub> must be at least 4 MHz.

- (3) The device should provide a data hold time of 300 ns at least in order to bridge the undefined region of the falling edge of SCL.

Figure 4-7. I2C bus timing diagram

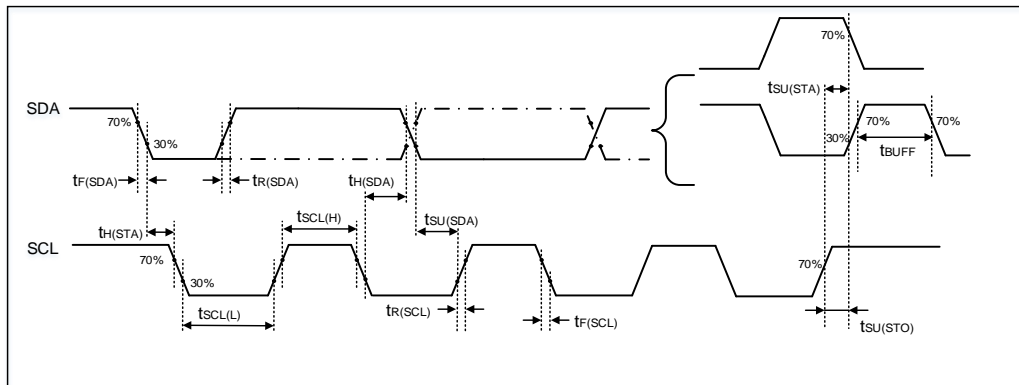

## 4.17. SPI characteristics

Table 4-39. Standard SPI characteristics<sup>(1)</sup>

Symbol	Parameter	Conditions	Min	Typ	Max	Unit
$f_{SCK}$	SCK clock frequency	—	—	—	30	MHz
$t_{SCK(H)}$	SCK clock high time	Master mode, $f_{PCLKx} = 100\text{ MHz}$ , presc = 4	18	20	22	ns
$t_{SCK(L)}$	SCK clock low time	Master mode, $f_{PCLKx} = 100\text{ MHz}$ , presc = 4	18	20	22	ns
<b>SPI master mode</b>						
$t_{V(MO)}$	Data output valid time	—	—	7	—	ns
$t_{H(MO)}$	Data output hold time	—	—	4	—	ns
$t_{SU(MI)}$	Data input setup time	—	2.2	—	—	ns
$t_{H(MI)}$	Data input hold time	—	0	—	—	ns
<b>SPI slave mode</b>						
$t_{SU(NSS)}$	NSS enable setup time	—	0	—	—	ns
$t_{H(NSS)}$	NSS enable hold time	—	3	—	—	ns
$t_{A(SO)}$	Data output access time	—	—	9	—	ns
$t_{DIS(SO)}$	Data output disable time	—	—	8	—	ns
$t_{V(SO)}$	Data output valid time	—	—	10	—	ns
$t_{H(SO)}$	Data output hold time	—	—	10	—	ns
$t_{SU(SI)}$	Data input setup time	—	0	—	—	ns
$t_{H(SI)}$	Data input hold time	—	2	—	—	ns

(1) Based on characterization, not tested in production.

Figure 4-8. SPI timing diagram - master mode

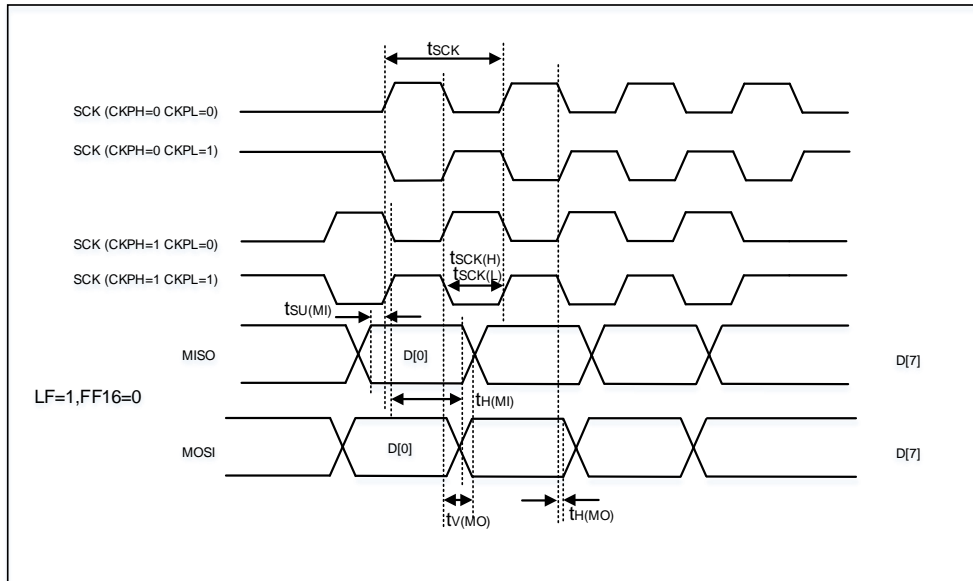
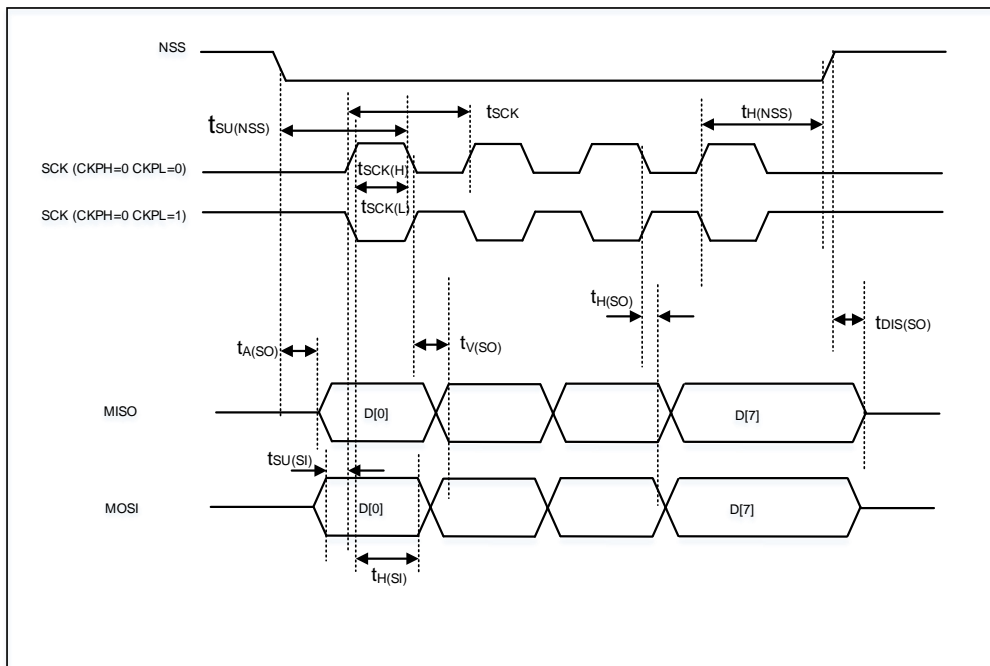

Figure 4-9. SPI timing diagram - slave mode



## 4.18. I2S characteristics

**Table 4-40. I2S characteristics<sup>(1)(2)</sup>**

Symbol	Parameter	Conditions	Min	Typ	Max	Unit
$f_{CK}$	Clock frequency	Master mode (data: 16 bits, Audio frequency = 96 kHz)	—	3.078	—	MHz
		Slave mode	—	10	—	
$t_H$	Clock high time	—	—	162	—	ns
$t_L$	Clock low time		—	163	—	ns
$t_{V(WS)}$	WS valid time	Master mode	—	2	—	ns
$t_{H(WS)}$	WS hold time	Master mode	—	2	—	ns
$t_{SU(WS)}$	WS setup time	Slave mode	0	—	—	ns
$t_{H(WS)}$	WS hold time	Slave mode	3	—	—	ns
$D_{CY(SCK)}$	I2S slave input clock duty cycle	Slave mode	—	50	—	%
$t_{SU(SD\_MR)}$	Data input setup time	Master mode	0	—	—	ns
$t_{SU(SD\_SR)}$	Data input setup time	Slave mode	0	—	—	ns
$t_{H(SD\_MR)}$	Data input hold time	Master receiver	1	—	—	ns
$t_{H(SD\_SR)}$		Slave receiver	3	—	—	ns
$t_{V(SD\_ST)}$	Data output valid time	Slave transmitter (after enable edge)	—	12	—	ns
$t_{H(SD\_ST)}$	Data output hold time	Slave transmitter (after enable edge)	—	10	—	ns
$t_{V(SD\_MT)}$	Data output valid time	Master transmitter (after enable edge)	—	10	—	ns
$t_{H(SD\_MT)}$	Data output hold time	Master transmitter (after enable edge)	—	7	—	ns

(1) Guaranteed by design, not tested in production.

(2) Based on characterization, not tested in production.

Figure 4-10. I2S timing diagram - master mode

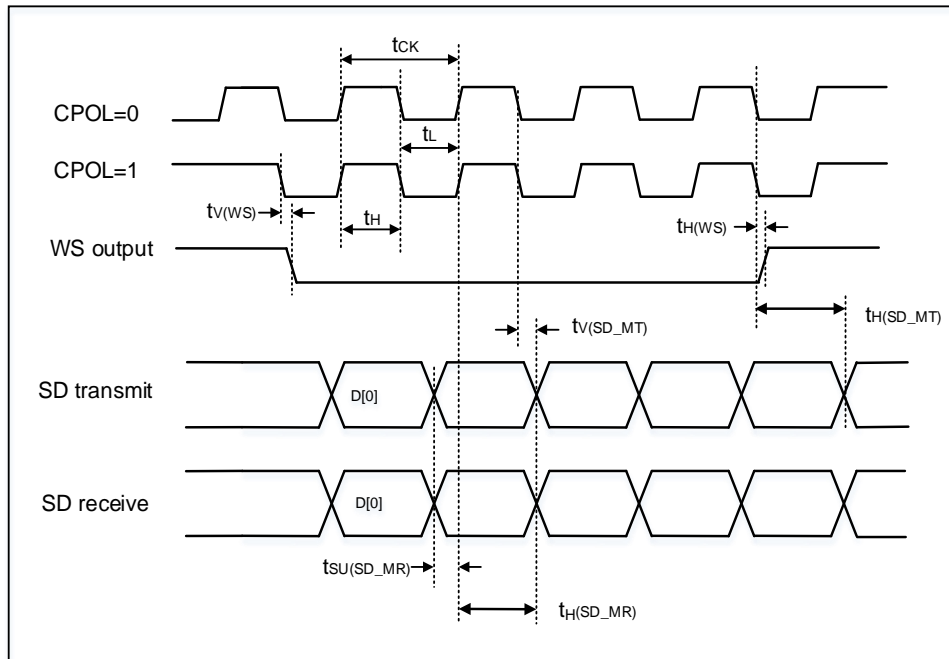
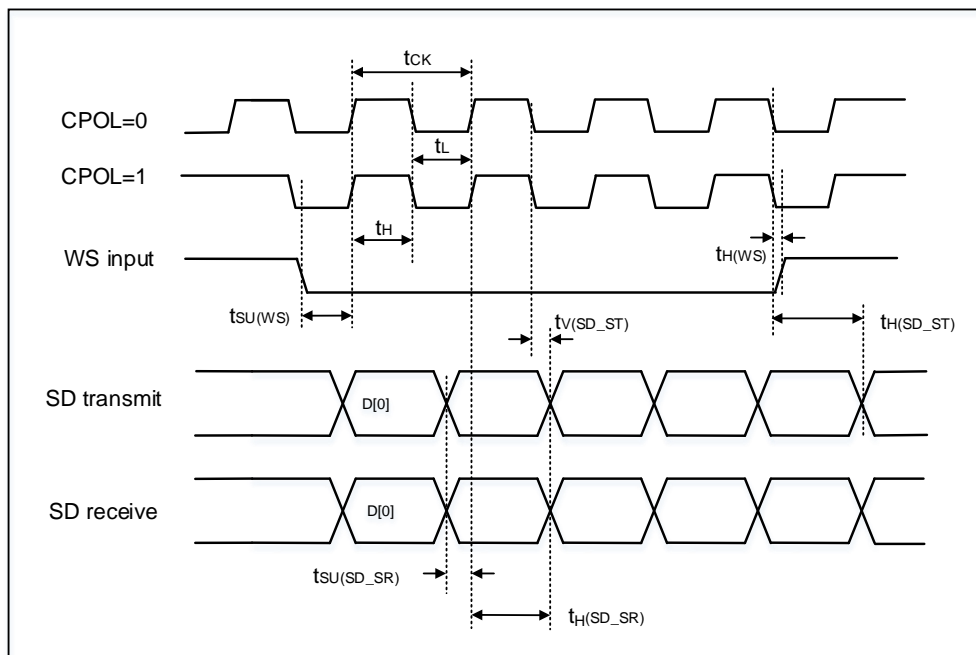

Figure 4-11. I2S timing diagram - slave mode



## 4.19. USART characteristics

**Table 4-41. USART characteristics<sup>(1)</sup>**

Symbol	Parameter	Conditions	Min	Typ	Max	Unit
$f_{SCK}$	SCK clock frequency	$f_{PCLKx} = 100 \text{ MHz}$	—	—	50	MHz
$t_{SCK(H)}$	SCK clock high time	$f_{PCLKx} = 100 \text{ MHz}$	10	—	—	ns
$t_{SCK(L)}$	SCK clock low time	$f_{PCLKx} = 100 \text{ MHz}$	10	—	—	ns

(1) Guaranteed by design, not tested in production.

## 4.20. SDIO characteristics

**Table 4-42. SDIO characteristics<sup>(1)(2)</sup>**

Symbol	Parameter	Conditions	Min	Typ	Max	Unit
$f_{PP}^{(3)}$	Clock frequency in data transfer mode	—	0	—	48	MHz
$t_{W(CKL)}^{(3)}$	Clock low time	$f_{pp} = 48 \text{ MHz}$	10.5	11	—	ns
$t_{W(CKH)}^{(3)}$	Clock high time	$f_{pp} = 48 \text{ MHz}$	9.5	10	—	ns
CMD, D inputs (referenced to CK) in MMC and SD HS mode						
$t_{ISU}^{(4)}$	Input setup time HS	$f_{pp} = 48 \text{ MHz}$	4	—	—	ns
$t_{IH}^{(4)}$	Input hold time HS	$f_{pp} = 48 \text{ MHz}$	3	—	—	ns
CMD, D outputs (referenced to CK) in MMC and SD HS mode						
$t_{OV}^{(3)}$	Output valid time HS	$f_{pp} = 48 \text{ MHz}$	—	—	13.8	ns
$t_{OH}^{(3)}$	Output hold time HS	$f_{pp} = 48 \text{ MHz}$	12	—	—	ns
CMD, D inputs (referenced to CK) in SD default mode						
$t_{ISUD}^{(4)}$	Input setup time SD	$f_{pp} = 24 \text{ MHz}$	3	—	—	ns
$t_{IHD}^{(4)}$	Input hold time SD	$f_{pp} = 24 \text{ MHz}$	3	—	—	ns
CMD, D outputs (referenced to CK) in SD default mode						
$t_{OVD}^{(3)}$	Output valid default time SD	$f_{pp} = 24 \text{ MHz}$	—	2.4	2.8	ns
$t_{OHD}^{(3)}$	Output hold default time SD	$f_{pp} = 24 \text{ MHz}$	0.8	—	—	ns

- (1) CLK timing is measured at 50% of  $V_{DD}$ .  
 (2) Capacitive load  $C_L = 30 \text{ pF}$ .  
 (3) Based on characterization, not tested in production.  
 (4) Guaranteed by design, not tested in production.

## 4.21. CAN characteristics

Refer to [Table 4-27. I/O port DC characteristics<sup>\(1\)</sup>](#) for more details on the input/output alternate function characteristics (CANTX and CANRX).

## 4.22. USBFS characteristics

**Table 4-43. USBFS start up time**

Symbol	Parameter	Max	Unit
$t_{STARTUP}^{(1)}$	USBFS startup time	1	$\mu s$

(1) Guaranteed by design, not tested in production.

**Table 4-44. USBFS DC electrical characteristics**

Symbol	Parameter	Conditions	Min	Typ	Max	Unit	
Input levels <sup>(1)</sup>	$V_{DD}$	USBFS operating voltage	—	3	—	3.6	V
	$V_{DI}$	Differential input sensitivity	—	0.2	—	—	
	$V_{CM}$	Differential common mode range	Includes $V_{DI}$ range	0.8	—	2.5	
	$V_{SE}$	Single ended receiver threshold	—	1.3	—	2.0	
Output levels <sup>(2)</sup>	$V_{OL}$	Static output level low	$R_L$ of 1.0 k $\Omega$ to 3.6 V	—	0.06	0.3	V
	$V_{OH}$	Static output level high	$R_L$ of 15 k $\Omega$ to $V_{SS}$	2.8	3.3	3.6	
$R_{PD}^{(2)}$	PA11, PA12(USBFS_DM/DP) PB14, PB15(USBHS_DM/DP)	$V_{IN} = V_{DD}$	17	21	25	k $\Omega$	
	PA9(USBFS_VBUS) PB13(USBHS_VBUS)		0.72	0.9	1.1		
$R_{PU}^{(2)}$	PA11, PA12(USBFS_DM/DP) PB14, PB15(USBHS_DM/DP)	$V_{IN} = V_{SS}$	1.2	1.5	1.8		
	PA9(USBFS_VBUS) PB13(USBHS_VBUS)		0.24	0.3	0.33		

(1) Guaranteed by design, not tested in production.

(2) Based on characterization, not tested in production.

**Table 4-45. USBFS full speed-electrical characteristics<sup>(1)</sup>**

Symbol	Parameter	Conditions	Min	Typ	Max	Unit
$t_R$	Rise time	$C_L = 50$ pF	4	—	20	ns
$t_F$	Fall time	$C_L = 50$ pF	4	—	20	ns
$t_{RFM}$	Rise/ fall time matching	$t_R / t_F$	90	—	110	%
$V_{CRS}$	Output signal crossover voltage	—	1.3	—	2.0	V

(1) Guaranteed by design, not tested in production.

**Figure 4-12. USBFS timings: definition of data signal rise and fall time**

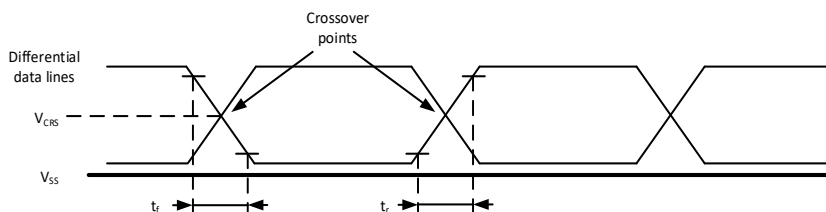

## 4.23. USBHS characteristics

**Table 4-46. USBHS clock timing parameters<sup>(1)</sup>**

Symbol	Parameter	Min	Typ	Max	Unit
V <sub>DD</sub>	USBHS operating voltage	3.0	—	3.6	V
f <sub>HCLK</sub>	f <sub>HCLK</sub> value to guarantee proper operation of USBHS interface	30	—	—	MHz
F <sub>START_8BIT</sub>	Frequency (first transition) 8-bit ± 10%	54	60	66	MHz
F <sub>STEADY</sub>	Frequency (steady state) ±500 ppm	59.97	60	60.63	MHz
D <sub>START_8BIT</sub>	Duty cycle (first transition) 8-bit ± 10%	40	50	60	%
D <sub>STEADY</sub>	Duty cycle (steady state) ±500 ppm	49.975	50	50.025	%

(1) Guaranteed by design, not tested in production.

**Table 4-47. USB-ULPI Dynamic characteristics**

Symbol	Parameter	Min	Typ	Max	Unit
t <sub>SC</sub>	Control in (ULPI_DIR, ULPI_NXT) setup time	—	—	2	ns
t <sub>HC</sub>	Control in (ULPI_DIR, ULPI_NXT) hold time	0.5	—	—	ns
t <sub>SD</sub>	Data in setup time	—	—	2	ns
t <sub>HD</sub>	Data in hold time	0	—	—	ns

(1) Guaranteed by design, not tested in production.

## 4.24. EXMC characteristics

**Table 4-48. Asynchronous non-multiplexed SRAM/PSRAM/NOR read timings<sup>(1)(2)(3)</sup>**

Symbol	Parameter	Min	Max	Unit
t <sub>w(NE)</sub>	EXMC_NE low time	24	26	ns
t <sub>v(NOE_NE)</sub>	EXMC_NEx low to EXMC_NOE low	0	—	ns
t <sub>w(NOE)</sub>	EXMC_NOE low time	24	26	ns
t <sub>h(NE_NOE)</sub>	EXMC_NOE high to EXMC_NE high hold time	0	—	ns
t <sub>v(A_NE)</sub>	EXMC_NEx low to EXMC_A valid	0	—	ns
t <sub>v(BL_NE)</sub>	EXMC_NEx low to EXMC_BL valid	0	—	ns
t <sub>su(DATA_NE)</sub>	Data to EXMC_NEx high setup time	19	—	ns
t <sub>su(DATA_NOE)</sub>	Data to EXMC_NOEx high setup time	19	—	ns
t <sub>h(DATA_NOE)</sub>	Data hold time after EXMC_NOE high	0	—	ns
t <sub>h(DATA_NE)</sub>	Data hold time after EXMC_NEx high	0	—	ns
t <sub>v(NADV_NE)</sub>	EXMC_NEx low to EXMC_NADV low	0	—	ns
t <sub>w(NADV)</sub>	EXMC_NADV low time	4	6	ns

(1) C<sub>L</sub> = 30 pF.

(2) Guaranteed by design, not tested in production.

(3) Based on configure: f<sub>HCLK</sub> = 200 MHz, AddressSetupTime = 0, AddressHoldTime = 1, DataSetupTime = 1.

**Table 4-49. Asynchronous non-multiplexed SRAM/PSRAM/NOR write timings<sup>(1)(2)(3)</sup>**

Symbol	Parameter	Min	Max	Unit
$t_{w(NE)}$	EXMC_NE low time	14	16	ns
$t_{v(NWE\_NE)}$	EXMC_NEx low to EXMC_NWE low	4	—	ns
$t_{w(NWE)}$	EXMC_NWE low time	4	6	ns
$t_{h(NE\_NWE)}$	EXMC_NWE high to EXMC_NE high hold time	4	6	ns
$t_{v(A\_NE)}$	EXMC_NEx low to EXMC_A valid	0	—	ns
$t_{v(NADV\_NE)}$	EXMC_NEx low to EXMC_NADV low	0	—	ns
$t_{w(NADV)}$	EXMC_NADV low time	4	6	ns
$t_{h(AD\_NADV)}$	EXMC_AD(address) valid hold time after EXMC_NADV high	9	—	ns
$t_{h(A\_NWE)}$	Address hold time after EXMC_NWE high	4	—	ns
$t_{h(BL\_NWE)}$	EXMC_BL hold time after EXMC_NWE high	4	—	ns
$t_{v(BL\_NE)}$	EXMC_NEx low to EXMC_BL valid	0	—	ns
$t_{v(DATA\_NADV)}$	EXMC_NADV high to DATA valid	0	—	ns
$t_{h(DATA\_NWE)}$	Data hold time after EXMC_NWE high	4	—	ns

(1)  $C_L = 30$  pF.

(2) Guaranteed by design, not tested in production.

(3) Based on configure:  $f_{HCLK} = 200$  MHz, AddressSetupTime = 0, AddressHoldTime = 1, DataSetupTime = 1.

**Table 4-50. Asynchronous multiplexed PSRAM/NOR read timings<sup>(1)(2)(3)</sup>**

Symbol	Parameter	Min	Max	Unit
$t_{w(NE)}$	EXMC_NE low time	34	36	ns
$t_{v(NOE\_NE)}$	EXMC_NEx low to EXMC_NOE low	14	—	ns
$t_{w(NOE)}$	EXMC_NOE low time	19	21	ns
$t_{h(NE\_NOE)}$	EXMC_NOE high to EXMC_NE high hold time	0	—	ns
$t_{v(A\_NE)}$	EXMC_NEx low to EXMC_A valid	0	—	ns
$t_{v(A\_NOE)}$	Address hold time after EXMC_NOE high	0	—	ns
$t_{v(BL\_NE)}$	EXMC_NEx low to EXMC_BL valid	0	—	ns
$t_{h(BL\_NOE)}$	EXMC_BL hold time after EXMC_NOE high	0	—	ns
$t_{su(DATA\_NE)}$	Data to EXMC_NEx high setup time	19	—	ns
$t_{su(DATA\_NOE)}$	Data to EXMC_NOEx high setup time	19	—	ns
$t_{h(DATA\_NOE)}$	Data hold time after EXMC_NOE high	0	—	ns
$t_{h(DATA\_NE)}$	Data hold time after EXMC_NEx high	0	—	ns
$t_{v(NADV\_NE)}$	EXMC_NEx low to EXMC_NADV low	0	—	ns
$t_{w(NADV)}$	EXMC_NADV low time	4	6	ns
$T_{h(AD\_NADV)}$	EXMC_AD(address) valid hold time after EXMC_NADV high	4	6	ns

(1)  $C_L = 30$  pF.

(2) Guaranteed by design, not tested in production.

(3) Based on configure:  $f_{HCLK} = 200$  MHz, AddressSetupTime = 0, AddressHoldTime = 1, DataSetupTime = 1.

**Table 4-51. Asynchronous multiplexed PSRAM/NOR write timings<sup>(1)(2)(3)</sup>**

Symbol	Parameter	Min	Max	Unit
$t_{w(NE)}$	EXMC_NE low time	24	26	ns

$t_{V(NWE\_NE)}$	EXMC_NEx low to EXMC_NWE low	4	—	ns
$t_{W(NWE)}$	EXMC_NWE low time	14	16	ns
$t_{h(NE\_NWE)}$	EXMC_NWE high to EXMC_NE high hold time	4	—	ns
$t_{V(A\_NE)}$	EXMC_NEx low to EXMC_A valid	0	—	ns
$t_{V(NADV\_NE)}$	EXMC_NEx low to EXMC_NADV low	0	—	ns
$t_{W(NADV)}$	EXMC_NADV low time	4	6	ns
$t_{h(AD\_NADV)}$	EXMC_AD(address) valid hold time after EXMC_NADV high	4	—	ns
$t_{h(A\_NWE)}$	Address hold time after EXMC_NWE high	4	—	ns
$t_{h(BL\_NWE)}$	EXMC_BL hold time after EXMC_NWE high	4	—	ns
$t_{V(BL\_NE)}$	EXMC_NEx low to EXMC_BL valid	0	—	ns
$t_{V(DATA\_NADV)}$	EXMC_NADV high to DATA valid	4	—	ns
$t_{h(DATA\_NWE)}$	Data hold time after EXMC_NWE high	4	—	ns

(1)  $C_L = 30$  pF.

(2) Guaranteed by design, not tested in production.

(3) Based on configure:  $f_{HCLK} = 200$  MHz, AddressSetupTime = 0, AddressHoldTime = 1, DataSetupTime = 1.

**Table 4-52. Synchronous multiplexed PSRAM/NOR read timings<sup>(1)(2)(3)</sup>**

Symbol	Parameter	Min	Max	Unit
$t_{W(CLK)}$	EXMC_CLK period	20	—	ns
$t_{d(CLKL-NExL)}$	EXMC_CLK low to EXMC_NEx low	0	—	ns
$t_{d(CLKH-NExH)}$	EXMC_CLK high to EXMC_NEx high	9	—	ns
$t_{d(CLKL-NADV L)}$	EXMC_CLK low to EXMC_NADV low	0	—	ns
$t_{d(CLKL-NADV H)}$	EXMC_CLK low to EXMC_NADV high	0	—	ns
$t_{d(CLKL-AV)}$	EXMC_CLK low to EXMC_Ax valid	0	—	ns
$t_{d(CLKH-AIV)}$	EXMC_CLK high to EXMC_Ax invalid	9	—	ns
$t_{d(CLKL-NOEL)}$	EXMC_CLK low to EXMC_NOE low	0	—	ns
$t_{d(CLKH-NOEH)}$	EXMC_CLK high to EXMC_NOE high	9	—	ns
$t_{d(CLKL-ADV)}$	EXMC_CLK low to EXMC_AD valid	0	—	ns
$t_{d(CLKL-ADIV)}$	EXMC_CLK low to EXMC_AD invalid	0	—	ns

(1)  $C_L = 30$  pF.

(2) Guaranteed by design, not tested in production.

(3) (Based on configure:  $f_{HCLK} = 200$  MHz, BurstAccessMode = Enable; Memory Type = PSRAM; WriteBurst = Enable; CLKDivision = 3 (EXMC\_CLK is 4 divided by HCLK); Data Latency = 1.

**Table 4-53. Synchronous multiplexed PSRAM write timings<sup>(1)(2)(3)</sup>**

Symbol	Parameter	Min	Max	Unit
$t_{W(CLK)}$	EXMC_CLK period	20	—	ns
$t_{d(CLKL-NExL)}$	EXMC_CLK low to EXMC_NEx low	0	—	ns
$t_{d(CLKH-NExH)}$	EXMC_CLK high to EXMC_NEx high	9	—	ns
$t_{d(CLKL-NADV L)}$	EXMC_CLK low to EXMC_NADV low	0	—	ns
$t_{d(CLKL-NADV H)}$	EXMC_CLK low to EXMC_NADV high	0	—	ns
$t_{d(CLKL-AV)}$	EXMC_CLK low to EXMC_Ax valid	0	—	ns
$t_{d(CLKH-AIV)}$	EXMC_CLK high to EXMC_Ax invalid	9	—	ns
$t_{d(CLKL-NWEL)}$	EXMC_CLK low to EXMC_NWE low	0	—	ns

$t_{d(CLKH-NWEH)}$	EXMC_CLK high to EXMC_NWE high	9	—	ns
$t_{d(CLKL-ADIV)}$	EXMC_CLK low to EXMC_AD invalid	0	—	ns
$t_{d(CLKL-DATA)}$	EXMC_A/D valid data after EXMC_CLK low	0	—	ns
$t_{h(CLKL-NBLH)}$	EXMC_CLK low to EXMC_NBL high	0	—	ns

- (1)  $C_L = 30$  pF.
- (2) Guaranteed by design, not tested in production.
- (3) Based on configure:  $f_{HCLK} = 200$  MHz, BurstAccessMode = Enable; MemoryType = PSRAM; WriteBurst = Enable; CLKDivision = 3 (EXMC\_CLK is 4 divided by HCLK); DataLatency = 1.

**Table 4-54. Synchronous non-multiplexed PSRAM/NOR read timings<sup>(1)(2)(3)</sup>**

Symbol	Parameter	Min	Max	Unit
$t_w(CLK)$	EXMC_CLK period	20	—	ns
$t_{d(CLKL-NExL)}$	EXMC_CLK low to EXMC_NEx low	0	—	ns
$t_{d(CLKH-NExH)}$	EXMC_CLK high to EXMC_NEx high	9	—	ns
$t_{d(CLKL-NADV L)}$	EXMC_CLK low to EXMC_NADV low	0	—	ns
$t_{d(CLKL-NADV H)}$	EXMC_CLK low to EXMC_NADV high	0	—	ns
$t_{d(CLKL-AV)}$	EXMC_CLK low to EXMC_Ax valid	0	—	ns
$t_{d(CLKH-AIV)}$	EXMC_CLK high to EXMC_Ax invalid	9	—	ns
$t_{d(CLKL-NOEL)}$	EXMC_CLK low to EXMC_NOE low	0	—	ns
$t_{d(CLKH-NOEH)}$	EXMC_CLK high to EXMC_NOE high	9	—	ns

- (1)  $C_L = 30$  pF.
- (2) Guaranteed by design, not tested in production.
- (3) Based on configure:  $f_{HCLK} = 200$  MHz, BurstAccessMode = Enable; MemoryType = PSRAM; WriteBurst = Enable; CLKDivision = 3 (EXMC\_CLK is 4 divided by HCLK); DataLatency = 1.

**Table 4-55. Synchronous non-multiplexed PSRAM write timings<sup>(1)(2)(3)</sup>**

Symbol	Parameter	Min	Max	Unit
$t_w(CLK)$	EXMC_CLK period	20	—	ns
$t_{d(CLKL-NExL)}$	EXMC_CLK low to EXMC_NEx low	0	—	ns
$t_{d(CLKH-NExH)}$	EXMC_CLK high to EXMC_NEx high	9	—	ns
$t_{d(CLKL-NADV L)}$	EXMC_CLK low to EXMC_NADV low	0	—	ns
$t_{d(CLKL-NADV H)}$	EXMC_CLK low to EXMC_NADV high	0	—	ns
$t_{d(CLKL-AV)}$	EXMC_CLK low to EXMC_Ax valid	0	—	ns
$t_{d(CLKH-AIV)}$	EXMC_CLK high to EXMC_Ax invalid	9	—	ns
$t_{d(CLKL-NWEL)}$	EXMC_CLK low to EXMC_NWE low	0	—	ns
$t_{d(CLKH-NWEH)}$	EXMC_CLK high to EXMC_NWE high	9	—	ns
$t_{d(CLKL-DATA)}$	EXMC_A/D valid data after EXMC_CLK low	0	—	ns
$t_{h(CLKL-NBLH)}$	EXMC_CLK low to EXMC_NBL high	0	—	ns

- (1)  $C_L = 30$  pF.
- (2) Guaranteed by design, not tested in production.
- (3) Based on configure:  $f_{HCLK} = 200$  MHz, BurstAccessMode = Enable; MemoryType = PSRAM; WriteBurst = Enable; CLKDivision = 3 (EXMC\_CLK is 4 divided by HCLK); DataLatency = 1.

## 4.25. TIMER characteristics

**Table 4-56. TIMER characteristics<sup>(1)</sup>**

Symbol	Parameter	Conditions	Min	Max	Unit
t <sub>res</sub>	Timer resolution time	—	1	—	t <sub>TIMERxCLK</sub>
		f <sub>TIMERxCLK</sub> = 200 MHz	5	—	ns
f <sub>EXT</sub>	Timer external clock frequency	—	0	f <sub>TIMERxCLK</sub> /2	MHz
		f <sub>TIMERxCLK</sub> = 200 MHz	0	100	MHz
RES	Timer resolution	TIMERx (except TIMER1 & TIMER4)	—	16	bit
		TIMER1 & TIMER4	—	32	bit
t <sub>COUNTER</sub>	16-bit counter clock period when internal clock is selected	—	1	65536	t <sub>TIMERxCLK</sub>
		f <sub>TIMERxCLK</sub> = 200 MHz	0.005	327.68	µs
t <sub>MAX_COUNT</sub>	Maximum possible count	—	—	65536x65536	t <sub>TIMERxCLK</sub>
		f <sub>TIMERxCLK</sub> = 200 MHz	—	21.47	s

(1) Guaranteed by design, not tested in production.

## 4.26. DCI characteristics

**Table 4-57. DCI characteristics<sup>(1)</sup>**

Symbol	Parameter	Min	Max	Unit
Frequency ratio	DCI_PIXCLK /fHCLK	—	0.4	
DCI_PIXCLK	Pixel clock input	—	80	MHz
D <sub>Pixel</sub>	Pixel clock input duty cycle	30	70	%
t <sub>su</sub> (DATA)	Data input setup time	2.5	—	ns
t <sub>h</sub> (DATA)	Data input hold time	1	—	ns
t <sub>su</sub> (HSYNC)	DCI_HS input setup time	2	—	ns
t <sub>su</sub> (VSYNC)	DCI_VS input setup time	2	—	ns
t <sub>h</sub> (HSYNC)	DCI_HS input hold time	0.5	—	ns
t <sub>h</sub> (VSYNC)	DCI_VS input hold time	0.5	—	ns

(1) Guaranteed by design, not tested in production.

## 4.27. WDGT characteristics

Table 4-58. FWDGT min/max timeout period at 32 kHz (IRC32K)<sup>(1)</sup>

Prescaler divider	PSC[2:0] bits	Min timeout RLD[11:0] = 0x000	Max timeout RLD[11:0] = 0xFF	Unit
1/4	000	0.03125	511.90625	ms
1/8	001	0.03125	1023.7812	
1/16	010	0.03125	2047.53125	
1/32	011	0.03125	4095.03125	
1/64	100	0.03125	8190.03125	
1/128	101	0.03125	16380.03125	
1/256	110 or 111	0.03125	32760.03125	

(1) Guaranteed by design, not tested in production.

Table 4-59. WWDGT min-max timeout value at 50 MHz ( $f_{PCLK1}$ )<sup>(1)</sup>

Prescaler divider	PSC[1:0]	Min timeout value CNT[6:0] = 0x40	Unit	Max timeout value CNT[6:0] = 0x7F	Unit
1/1	00	81.92	μs	5.24	ms
1/2	01	163.84		10.49	
1/4	10	327.68		20.97	
1/8	11	655.36		41.94	

(1) Guaranteed by design, not tested in production.

## 4.28. Parameter conditions

Unless otherwise specified, all values given for  $V_{DD} = V_{DDA} = 3.3\text{ V}$ ,  $T_A = 25\text{ }^\circ\text{C}$ .

## 5. Package information

### 5.1 BGA176 package outline dimensions

Figure 5-1. BGA176 package outline

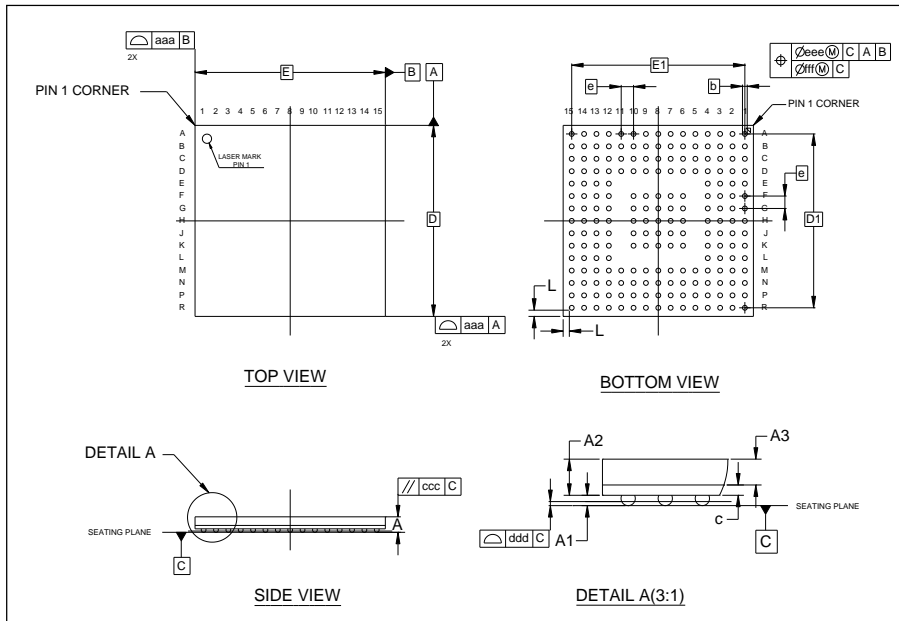
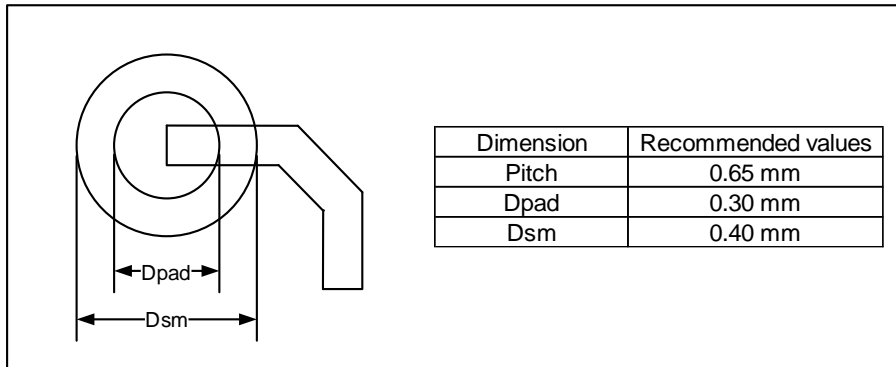

Table 5-1. BGA176 package dimensions

Symbol	Min	Typ	Max
A	—	—	0.89
A1	0.13	0.18	0.23
A2	0.58	0.63	0.68
A3	—	0.45	—
b	0.20	0.25	0.30
c	0.15	0.18	0.21
D	9.90	10.00	10.10
D1	—	9.10	—
E	9.90	10.00	10.10
E1	—	9.10	—
e	—	0.65	—
L	—	0.325	—
aaa	—	0.10	—
ccc	—	0.20	—
ddd	—	0.08	—
eee	—	0.15	—
fff	—	0.08	—

(Original dimensions are in millimeters)

Figure 5-2. BGA176 recommended footprint



(Original dimensions are in millimeters)

## 5.2 LQFP144 package outline dimensions

Figure 5-3. LQFP144 package outline

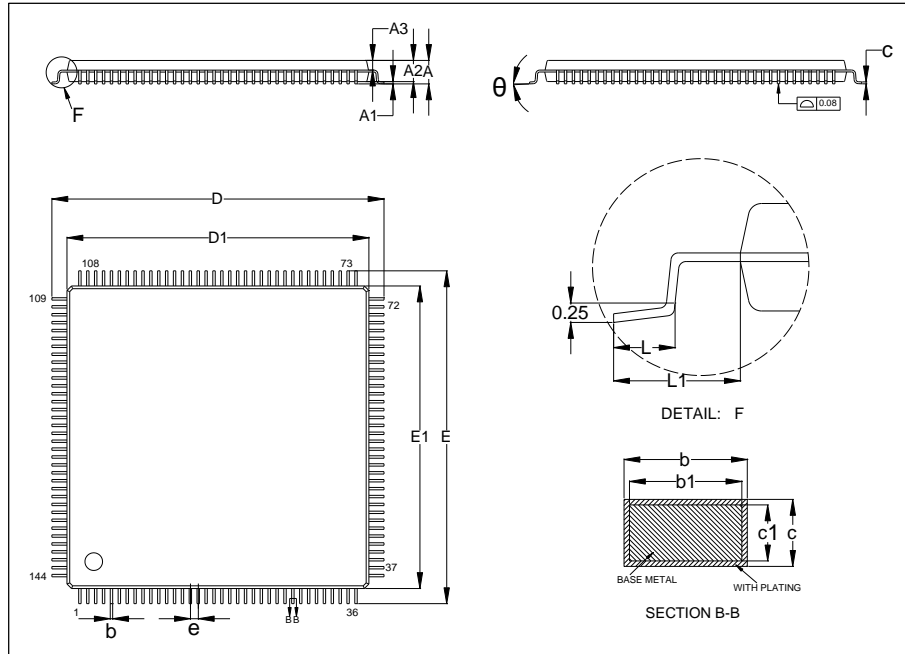
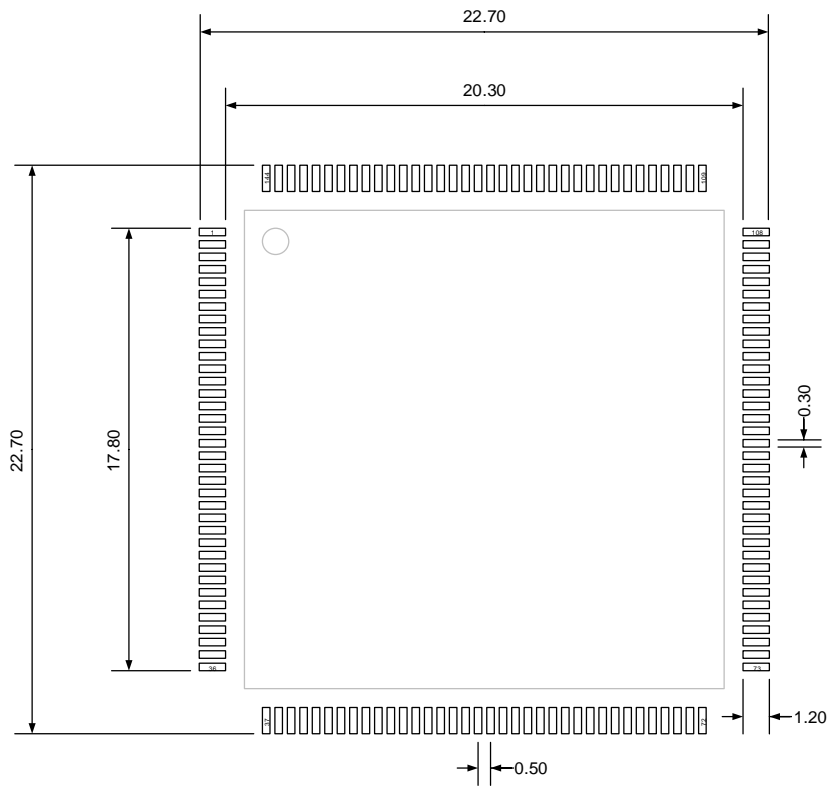

Table 5-2. LQFP144 package dimensions

Symbol	Min	Typ	Max
A	—	—	1.60
A1	0.05	—	0.15
A2	1.35	1.40	1.45
A3	0.59	0.64	0.69
b	0.18	—	0.26
b1	0.17	0.20	0.23
c	0.13	—	0.17
c1	0.12	0.13	0.14
D	21.80	22.00	22.20
D1	19.90	20.00	20.10
E	21.80	22.00	22.20
E1	19.90	20.00	20.10
e	—	0.50	—
L	0.45	—	0.75
L1	—	1.00	—
$\theta$	0°	—	7°

(Original dimensions are in millimeters)

Figure 5-4. LQFP144 recommended footprint



(Original dimensions are in millimeters)

### 5.3 LQFP100 package outline dimensions

Figure 5-5. LQFP100 package outline

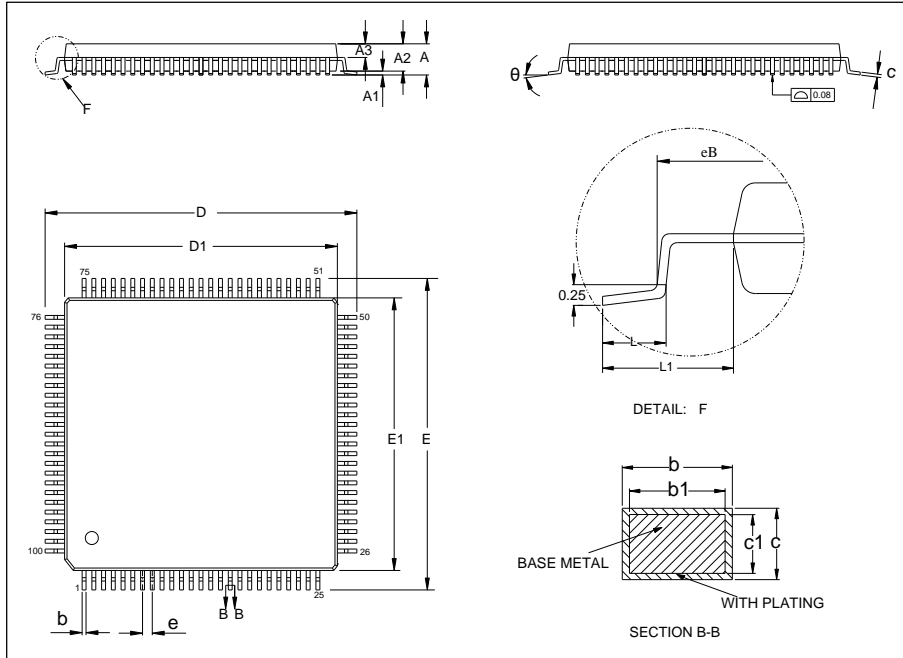
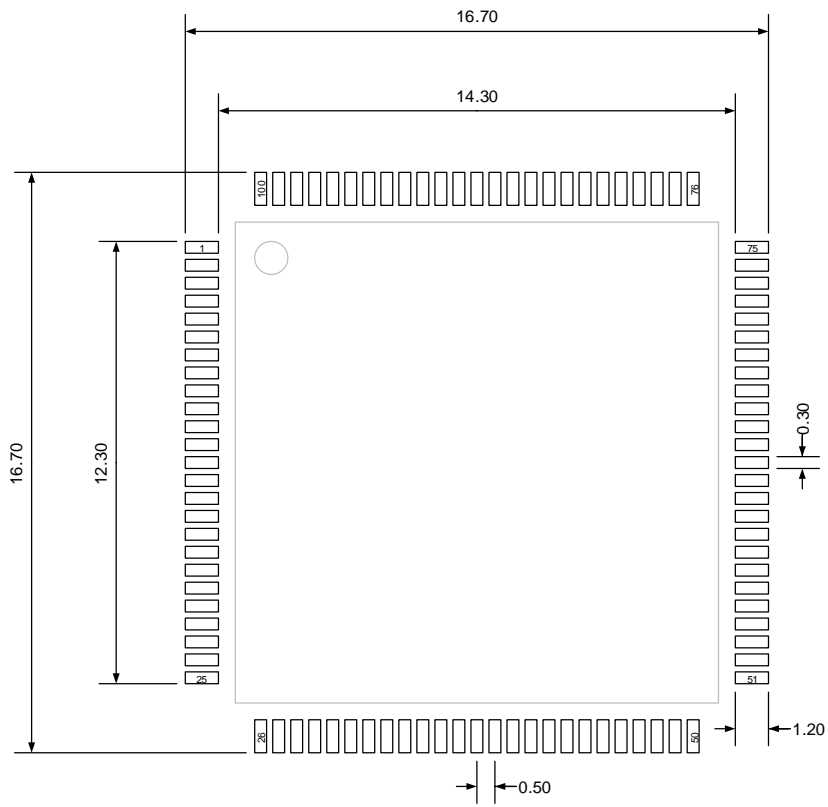

Table 5-3. LQFP100 package dimensions

Symbol	Min	Typ	Max
A	—	—	1.60
A1	0.05	—	0.15
A2	1.35	1.40	1.45
A3	0.59	0.64	0.69
b	0.18	—	0.26
b1	0.17	0.20	0.23
c	0.13	—	0.17
c1	0.12	0.13	0.14
D	15.80	16.00	16.20
D1	13.90	14.00	14.10
E	15.80	16.00	16.20
E1	13.90	14.00	14.10
e	—	0.50	—
eB	15.05	—	15.35
L	0.45	—	0.75
L1	—	1.00	—
θ	0°	—	7°

(Original dimensions are in millimeters)

Figure 5-6. LQFP100 recommended footprint



(Original dimensions are in millimeters)

## 5.4 Thermal characteristics

Thermal resistance is used to characterize the thermal performance of the package device, which is represented by the Greek letter “ $\theta$ ”. For semiconductor devices, thermal resistance represents the steady-state temperature rise of the chip junction due to the heat dissipated on the chip surface.

$\theta_{JA}$ : Thermal resistance, junction-to-ambient.

$\theta_{JB}$ : Thermal resistance, junction-to-board.

$\theta_{JC}$ : Thermal resistance, junction-to-case.

$\Psi_{JB}$ : Thermal characterization parameter, junction-to-board.

$\Psi_{JT}$ : Thermal characterization parameter, junction-to-top center.

$$\theta_{JA}=(T_J-T_A)/P_D \quad (5-1)$$

$$\theta_{JB}=(T_J-T_B)/P_D \quad (5-2)$$

$$\theta_{JC}=(T_J-T_C)/P_D \quad (5-3)$$

Where,  $T_J$  = Junction temperature.

$T_A$  = Ambient temperature

$T_B$  = Board temperature

$T_C$  = Case temperature which is monitoring on package surface

$P_D$  = Total power dissipation

$\theta_{JA}$  represents the resistance of the heat flows from the heating junction to ambient air. It is an indicator of package heat dissipation capability. Lower  $\theta_{JA}$  can be considerate as better overall thermal performance.  $\theta_{JA}$  is generally used to estimate junction temperature.

$\theta_{JB}$  is used to measure the heat flow resistance between the chip surface and the PCB board.

$\theta_{JC}$  represents the thermal resistance between the chip surface and the package top case.  $\theta_{JC}$  is mainly used to estimate the heat dissipation of the system (using heat sink or other heat dissipation methods outside the device package).

**Table 5-4. Package thermal characteristics<sup>(1)</sup>**

Symbol	Condition	Package	Value	Unit
$\theta_{JA}$	Natural convection, 2S2P PCB	BGA176	45.02	°C/W
		LQFP144	48.76	
		LQFP100	57.42	
$\theta_{JB}$	Cold plate, 2S2P PCB	BGA176	26.55	°C/W
		LQFP144	35.00	
		LQFP100	31.68	
$\theta_{JC}$	Cold plate, 2S2P PCB	BGA176	9.93	°C/W

Symbol	Condition	Package	Value	Unit
		LQFP144	12.03	
		LQFP100	13.85	
$\Psi_{JB}$	Natural convection, 2S2P PCB	BGA176	28.31	°C/W
		LQFP144	35.32	
		LQFP100	41.28	
$\Psi_{JT}$	Natural convection, 2S2P PCB	BGA176	0.69	°C/W
		LQFP144	1.86	
		LQFP100	0.75	

(1) Thermal characteristics are based on simulation, and meet JEDEC specification.

## 6. Ordering information

**Table 6-1. Part ordering code for GD32F450xx devices**

Ordering code	Flash (KB)	Package	Package type	Temperature operating range
GD32F450IKH6	3072	BGA176	Green	Industrial -40°C to +85°C
GD32F450IIH6	2048	BGA176	Green	Industrial -40°C to +85°C
GD32F450IGH6	1024	BGA176	Green	Industrial -40°C to +85°C
GD32F450ZKT6	3072	LQFP144	Green	Industrial -40°C to +85°C
GD32F450ZIT6	2048	LQFP144	Green	Industrial -40°C to +85°C
GD32F450ZGT6	1024	LQFP144	Green	Industrial -40°C to +85°C
GD32F450ZET6	512	LQFP144	Green	Industrial -40°C to +85°C
GD32F450VKT6	3072	LQFP100	Green	Industrial -40°C to +85°C
GD32F450VIT6	2048	LQFP100	Green	Industrial -40°C to +85°C
GD32F450VGT6	1024	LQFP100	Green	Industrial -40°C to +85°C
GD32F450VGT7	1024	LQFP100	Green	Industrial -40°C to +105°C
GD32F450VET6	512	LQFP100	Green	Industrial -40°C to +85°C

## 7. Revision history

**Table 7-1. Revision history**

Revision No.	Description	Date
1.0	Initial Release	Oct. 25, 2016
1.1	Pin alternate functions summary updated	Oct. 29, 2016
1.2	Repair history accumulation error	Jan.24, 2018
2.0	Repair history accumulation error and electrical characteristics updated	May.19, 2020
2.1	<ol style="list-style-type: none"> <li>Update BGA176 parameter A max in <b><u>Table 5-1. BGA176 package dimensions</u></b>, the value changes from 0.84mm to 0.89mm</li> <li>Update Memory characteristics in <b><u>Table 4-24. Flash memory characteristics</u></b>.</li> <li>Modify the DCMI to DCI in chapter <b><u>DCI characteristics</u></b>.</li> <li>Modify LDO in run mode to LDO in normal power and normal driver mode, LDO in low power mode to LDO in normal power and low driver mode, Main LDO in under drive mode to LDO in low power and normal drive mode, Low Power LDO in under driver mode to LDO in low power and low drive mode in <b><u>Table 4-7. Power consumption characteristics</u></b><sup>(2)(3)(4)(5)</sup>.</li> <li>Modify the second DAC_OUT min to DAC_OUT max in <b><u>Table 4-36. DAC characteristics</u></b>.</li> <li>Changed the range of T<sub>STG</sub> from -55-+150°C to -65-150°C in <b><u>Table 4-1. Absolute maximum ratings</u></b><sup>(1)(4)</sup>.</li> <li>Delete Fast mode Plus and add parameter t<sub>s(STA)</sub>, t<sub>s(STO)</sub> and t<sub>buff</sub>, update I2C Timing diagram in <b><u>I2C characteristics</u></b>.</li> <li>Update the SPI Timing diagram in chapter <b><u>SPI characteristics</u></b>.</li> </ol>	May.31, 2021
2.2	<ol style="list-style-type: none"> <li>Correct the value of VREFP in <b><u>Table 4-28. ADC characteristics</u></b>.</li> </ol>	Oct.18, 2021
2.3	<ol style="list-style-type: none"> <li>Update <b><u>Table 4-1. Absolute maximum ratings</u></b><sup>(1)(4)</sup>, <b><u>Table 4-5. Table 4-7 Power consumption characteristics</u></b><sup>(2)(3)(4)(5)</sup>, <b><u>Table 4-11. Power supply supervisor characteristics</u></b> and <b><u>Table 4-12. ESD characteristics</u></b><sup>(1)</sup>.</li> <li>Update <b><u>Figure 4-8. SPI timing diagram – master</u></b>.</li> </ol>	Jul.12, 2022

Revision No.	Description	Date
	<p><u>mode</u>, <u>Figure 4-9. SPI timing diagram – slave mode</u>, <u>Figure 4-10. I2S timing diagram – master mode</u>, <u>Figure 4-11. I2S timing diagram – slave mode</u>, <u>Table 4-39. Standard SPI characteristics<sup>(1)</sup></u> and <u>Table 4-40. I2S characteristics<sup>(1)(2)</sup></u>.</p> <p>3. Update <u>Table 4-20. Low speed internal clock (IRC32K) characteristics</u>, <u>Table 4-26. NRST pin characteristics</u> and <u>Table 4-28. I/O port AC characteristics<sup>(1)(2)</sup></u>.</p> <p>4. Add <u>Figure 4-4. Recommended PDR ON pin circuit</u> and <u>Table 4-10. EMI characteristics<sup>(1)</sup></u>.</p> <p>5. Update <u>Table 4-38. I2C characteristics<sup>(1)(2)</sup></u> and <u>Table 4-41. USART characteristics<sup>(1)</sup></u>.</p>	
2.4	<p>1. Add notes for <u>Table 4-2. DC operating conditions</u> and <u>Table 4-7. Power consumption characteristics<sup>(2)(3)(4)(5)(6)</sup></u>, and update <u>Table 4-7. Power consumption characteristics<sup>(2)(3)(4)(5)(6)</sup></u>.</p> <p>2. Update <u>Table 4-25. Flash memory characteristics<sup>(1)</sup></u>.</p> <p>3. Add description of EMI and <u>Table 4-10. EMI characteristics<sup>(1)</sup></u>.</p> <p>4. Update <u>Figure 4-7. I2C bus timing diagram</u>.</p>	Jan. 4, 2023
2.5	<p>1. Update clock tree.</p> <p>2. Update <u>Table 2-3. GD32F450lx BGA176 pin definitions</u>, <u>Table 2-4. GD32F450Zx LQFP144 pin definitions</u>, <u>Table 2-5. GD32F450Vx LQFP100 pin definitions</u> and <u>Figure 4-1. Recommended power supply decoupling capacitors<sup>(1)(2)</sup></u>.</p>	Jul. 8, 2023
2.6	<p>1. Modify description note(3) of <u>Table 4-27. I/O port DC characteristics<sup>(1)(3)</sup></u>.</p> <p>2. Modify <u>Table 4-27. I/O port DC characteristics<sup>(1)(3)</sup></u>.</p> <p>3. Modify <u>Figure 5-1. LQFP144 package outline</u>, <u>Figure 5-5. LQFP100 package outline</u> and <u>Figure 5-7. LQFP64 package outline</u>.</p> <p>4. Modify <u>Table 4-5. Start-up timings of Operating conditions<sup>(1)(2)(3)</sup></u>.</p>	Jul. 15, 2024
2.7	<p>1. Update ADC parameters, note for VREFP power on timing.</p> <p>2. Add GD32F450VGT7</p>	Nov. 8, 2024
2.8	<p>1. Modify DAC to DAC0 in chapter <u>2. Device-overview</u>.</p> <p>2. Update the parameters <math>f_{P\_LLOUT}</math> and <math>f_{VCO}</math> in <u>Table 4-21</u>.</p>	Jan. 23, 2025

Revision No.	Description	Date
	<p><b><u>PLL characteristic, Table 4-22. PLLI2S characteristic and Table 4-23. PLLSAI characteristic.</u></b></p> <p>3. Update <b><u>Figure 4-4. Recommended PDR ON pin circuit</u></b> and note.</p> <p>4. Update description in chapter <b><u>3.13. Serial peripheral interface</u></b> and <b><u>3.14 Universal synchronous/asynchronous receiver transmitter (USART/UART).</u></b></p> <p>5. Update the descripton of <math>t_{h}(\text{DATA})</math> in <b><u>Table 4-57. DCI characteristics<sup>(1)</sup>.</u></b></p>	
2.9	<p>1. Change 1.2V domaon to <math>V_{\text{CORE}}</math> domain in chapter <b><u>3.5. Power saving modes.</u></b></p> <p>2. Update <b><u>Table 4-2. DC operating conditions.</u></b></p> <p>3. Update <b><u>Table 4-5. Start-up timings of Operating conditions<sup>(1)(2)(3)</sup></u></b> and <b><u>Table 4-6. Power saving mode wakeup timings characteristics<sup>(1)</sup>.</u></b></p> <p>4. Correct the typos in <b><u>Table 4-16. Low speed external clock (LXTAL) generated from a crystal/ceramic characteristics.</u></b></p>	Jan. 26, 2026

## Important Notice

This document is the property of GigaDevice Semiconductor Inc. and its subsidiaries (the "Company"). This document, including any product of the Company described in this document (the "Product"), is owned by the Company according to the laws of the People's Republic of China and other applicable laws. The Company reserves all rights under such laws and no Intellectual Property Rights are transferred (either wholly or partially) or licensed by the Company (either expressly or impliedly) herein. The names and brands of third party referred thereto (if any) are the property of their respective owner and referred to for identification purposes only.

To the maximum extent permitted by applicable law, the Company makes no representations or warranties of any kind, express or implied, with regard to the merchantability and the fitness for a particular purpose of the Product, nor does the Company assume any liability arising out of the application or use of any Product. Any information provided in this document is provided only for reference purposes. It is the sole responsibility of the user of this document to determine whether the Product is suitable and fit for its applications and products planned, and properly design, program, and test the functionality and safety of its applications and products planned using the Product. The Product is designed, developed, and/or manufactured for ordinary business, industrial, personal, and/or household applications only, and the Product is not designed or intended for use in (i) safety critical applications such as weapons systems, nuclear facilities, atomic energy controller, combustion controller, aeronautic or aerospace applications, traffic signal instruments, pollution control or hazardous substance management; (ii) life-support systems, other medical equipment or systems (including life support equipment and surgical implants); (iii) automotive applications or environments, including but not limited to applications for active and passive safety of automobiles (regardless of front market or aftermarket), for example, EPS, braking, ADAS (camera/fusion), EMS, TCU, BMS, BSG, TPMS, Airbag, Suspension, DMS, ICMS, Domain, ESC, DCDC, e-clutch, advanced-lighting, etc.. Automobile herein means a vehicle propelled by a self-contained motor, engine or the like, such as, without limitation, cars, trucks, motorcycles, electric cars, and other transportation devices; and/or (iv) other uses where the failure of the device or the Product can reasonably be expected to result in personal injury, death, or severe property or environmental damage (collectively "Unintended Uses"). Customers shall take any and all actions to ensure the Product meets the applicable laws and regulations. The Company is not liable for, in whole or in part, and customers shall hereby release the Company as well as its suppliers and/or distributors from, any claim, damage, or other liability arising from or related to all Unintended Uses of the Product. Customers shall indemnify and hold the Company, and its officers, employees, subsidiaries, affiliates as well as its suppliers and/or distributors harmless from and against all claims, costs, damages, and other liabilities, including claims for personal injury or death, arising from or related to any Unintended Uses of the Product. Information in this document is provided solely in connection with the Product. The Company reserves the right to make changes, corrections, modifications or improvements to this document and the Product described herein at any time without notice. The Company shall have no responsibility whatsoever for conflicts or incompatibilities arising from future changes to them. Information in this document supersedes and replaces information previously supplied in any prior versions of this document.