

GigaDevice Semiconductor Inc.

GD32A508xx

Arm[®] Cortex[®]-M33 32-bit MCU

Datasheet

Revision 1.3

(Jan. 2026)

Table of Contents

Table of Contents	1
List of Figures	4
List of Tables	5
1. General description	7
2. Device overview	8
2.1. Device information	8
2.2. Block diagram.....	9
2.3. Pinouts and pin assignment	10
2.4. Memory map	12
2.5. Clock tree	16
2.6. Pin definitions.....	17
2.6.1. GD32A508Zx LQFP144 pin definitions	17
2.6.2. GD32A508Vx LQFP100 pin definitions	27
3. Functional description	35
3.1. Arm® Cortex®-M33 core	35
3.2. Embedded memory	35
3.3. Clock, reset and supply management.....	36
3.4. Boot modes.....	36
3.5. Power saving modes	37
3.6. Analog to digital converter (ADC)	38
3.7. Digital to analog converter (DAC).....	38
3.8. DMA	38
3.9. General-purpose inputs/outputs (GPIOs)	39
3.10. Timers and PWM generation	39
3.11. Real time clock (RTC)	40
3.12. Inter-integrated circuit (I2C)	41
3.13. Serial peripheral interface (SPI)	41
3.14. Universal synchronous asynchronous receiver transmitter (USART)	42
3.15. Inter-IC sound (I2S)	42
3.16. Universal serial bus High-Speed interface (USBHS)	42

3.17.	Controller area network (CAN)	43
3.18.	Ethernet (ENET).....	43
3.19.	External memory controller (EXMC)	43
3.20.	Comparators (CMP).....	44
3.21.	Trigonometric Math Unit (TMU).....	44
3.22.	Super High-Resolution Timer (SHRTIMER)	44
3.23.	Serial/Quad Parallel Interface (SQPI)	44
3.24.	Debug mode	45
3.25.	Package and operation temperature.....	45
4.	Electrical characteristics.....	46
4.1.	Absolute maximum ratings.....	46
4.2.	Operating conditions characteristics.....	46
4.3.	Power consumption	48
4.4.	EMC characteristics	55
4.5.	Power supply supervisor characteristics	55
4.6.	Electrical sensitivity	56
4.7.	External clock characteristics	57
4.8.	Internal clock characteristics	59
4.9.	PLL characteristics.....	60
4.10.	Memory characteristics	62
4.11.	NRST pin characteristics	62
4.12.	GPIO characteristics	63
4.13.	Temperature sensor characteristics.....	64
4.14.	ADC characteristics	65
4.15.	DAC characteristics	68
4.16.	Comparators characteristics.....	69
4.17.	Trigonometric Math Unit (TMU) characteristics	69
4.18.	I2C characteristics	70
4.19.	SPI characteristics	70
4.20.	I2S characteristics.....	73
4.21.	USART characteristics.....	75
4.22.	CAN characteristics	75



4.23.	USBHS characteristics	75
4.24.	EXMC characteristics.....	77
4.25.	Serial/Quad Parallel Interface (SQPI) characteristics	81
4.26.	Super High-resolution Timer (SHRTIMER) characteristics	81
4.27.	TIMER characteristics.....	83
4.28.	WDGT characteristics	84
4.29.	Parameter condition.....	84
5.	Package information.....	85
5.1.	LQFP144 package outline dimensions.....	85
5.2.	LQFP100 package outline dimensions.....	87
5.3.	Thermal characteristics	89
6.	Ordering information	91
7.	Revision history	92

List of Figures

Figure 2-1. GD32A508xx block diagram	9
Figure 2-2. GD32A508Zx LQFP144 pinouts	10
Figure 2-3. GD32A508Vx LQFP100 pinouts	11
Figure 2-4. GD32A508xx clock tree.....	16
Figure 4-1. Recommended power supply decoupling capacitors ⁽¹⁾⁽²⁾	47
Figure 4-2. Typical supply current consumption in Run mode	54
Figure 4-3. Typical supply current consumption in Sleep mode.....	54
Figure 4-4. Recommended external NRST pin circuit ⁽¹⁾	63
Figure 4-5. I2C bus timing diagram.....	70
Figure 4-6. SPI timing diagram - master mode	71
Figure 4-7. SPI timing diagram - slave mode.....	72
Figure 4-8. I2S timing diagram - master mode	74
Figure 4-9. I2S timing diagram - slave mode	74
Figure 4-10. USBFS timings: definition of data signal rise and fall time	77
Figure 5-1. LQFP144 package outline	85
Figure 5-2. LQFP144 recommended footprint	86
Figure 5-3. LQFP100 package outline	87
Figure 5-4. LQFP100 recommended footprint	88

List of Tables

Table 2-1. GD32A508xx devices features and peripheral list	8
Table 2-2. GD32A508xx memory map	12
Table 2-3. GD32A508Zx LQFP144 pin definitions	17
Table 2-4. GD32A508Vx LQFP100 pin definitions	27
Table 4-1. Absolute maximum ratings ⁽¹⁾⁽⁴⁾	46
Table 4-2. DC operating conditions	46
Table 4-3. Clock frequency ⁽¹⁾	47
Table 4-4. Operating conditions at Power up/ Power down ⁽¹⁾	47
Table 4-5. Start-up timings of Operating conditions ⁽¹⁾⁽²⁾⁽³⁾	47
Table 4-6. Power saving mode wakeup timings characteristics ⁽¹⁾⁽²⁾	48
Table 4-7. Power consumption characteristics ⁽²⁾⁽³⁾⁽⁴⁾⁽⁵⁾⁽⁶⁾	48
Table 4-8. EMI characteristics ⁽¹⁾	55
Table 4-9. Power supply supervisor characteristics.....	55
Table 4-10. ESD and static latch-up characteristics ^{(1) (2) (3)}	56
Table 4-11. High speed external clock (HXTAL) generated from a crystal/ceramic characteristics. 57	
Table 4-12. High speed external clock characteristics (HXTAL in bypass mode)	57
Table 4-13. Low speed external clock (LXTAL) generated from a crystal/ceramic characteristics.. 57	
Table 4-14. Low speed external user clock characteristics (LXTAL in bypass mode).....	58
Table 4-15. High speed internal clock (IRC8M) characteristics	59
Table 4-16. Low speed internal clock (IRC40K) characteristics	59
Table 4-17. High speed internal clock (IRC48M) characteristics	60
Table 4-18. PLL characteristics.....	60
Table 4-19. PLL1 characteristics.....	61
Table 4-20. PLL2 characteristics.....	61
Table 4-21. PLLUSB characteristics	61
Table 4-22. PLL spread spectrum clock generation (SSCG) characteristics ⁽¹⁾	61
Table 4-23. Flash memory characteristics	62
Table 4-24. NRST pin characteristics	62
Table 4-25. I/O port DC characteristics ⁽¹⁾⁽³⁾	63
Table 4-26. I/O port AC characteristics ⁽¹⁾⁽²⁾⁽⁴⁾	64
Table 4-27. Temperature sensor characteristics ⁽¹⁾	64
Table 4-28. ADC characteristics.....	65
Table 4-29. ADC R _{AIN} max for f _{ADC} = 35 MHz.....	65
Table 4-30. ADC dynamic accuracy at f _{ADC} = 14 MHz V _{DDA} = 1.8 V ⁽¹⁾	66
Table 4-31. ADC dynamic accuracy at f _{ADC} = 35 MHz V _{DDA} = 3.3 V ⁽¹⁾	66
Table 4-32. ADC dynamic accuracy at f _{ADC} = 35 MHz V _{DDA} = 2.4 V ⁽¹⁾	66
Table 4-33. ADC static accuracy at f _{ADC} = 14 MHz V _{DDA} = 1.8 V ⁽¹⁾	66
Table 4-34. ADC static accuracy at f _{ADC} = 35 MHz V _{DDA} = 3.3 V ⁽¹⁾	67
Table 4-35. ADC static accuracy at f _{ADC} = 35 MHz V _{DDA} = 2.4 V ⁽¹⁾	67
Table 4-36. DAC characteristics.....	68
Table 4-37. CMP characteristics ⁽¹⁾	69



Table 4-38. TMU supported instructions characteristics ⁽¹⁾ 69

Table 4-39. I2C characteristics ⁽¹⁾⁽²⁾⁽³⁾ 70

Table 4-40. I2C analog filter delay characteristics⁽¹⁾ 70

Table 4-41. Standard SPI characteristics ⁽¹⁾ 70

Table 4-42. I2S characteristics ⁽¹⁾⁽²⁾ 73

Table 4-43. USART characteristics ⁽¹⁾ 75

Table 4-44. USBHS DC electrical characteristics 75

Table 4-45. USBHS dynamic characteristics⁽¹⁾ 76

Table 4-46. USBHS Charger Detection characteristics ⁽¹⁾..... 76

Table 4-47. USBHS clock timing parameters ⁽¹⁾ 76

Table 4-48. USB-ULPI Dynamic characteristics ⁽¹⁾ 76

Table 4-49. Asynchronous non-multiplexed SRAM/PSRAM/NOR read timings ⁽¹⁾⁽²⁾⁽³⁾ 77

Table 4-50. Asynchronous non-multiplexed SRAM/PSRAM/NOR write timings ⁽¹⁾⁽²⁾⁽³⁾ 77

Table 4-51. Asynchronous multiplexed PSRAM/NOR read timings ⁽¹⁾⁽²⁾⁽³⁾ 78

Table 4-52. Asynchronous multiplexed PSRAM/NOR write timings ⁽¹⁾⁽²⁾⁽³⁾ 78

Table 4-53. Synchronous multiplexed PSRAM/NOR read timings ⁽¹⁾⁽²⁾⁽³⁾⁽⁴⁾ 79

Table 4-54. Synchronous multiplexed PSRAM write timings ⁽¹⁾⁽²⁾⁽³⁾ 79

Table 4-55. Synchronous non-multiplexed PSRAM/NOR read timings ⁽¹⁾⁽²⁾⁽³⁾ 80

Table 4-56. Synchronous non-multiplexed PSRAM write timings ⁽¹⁾⁽²⁾⁽³⁾ 80

Table 4-57. SQPI characteristics 81

Table 4-58. SHRTIMER characteristics ⁽¹⁾ 81

Table 4-59. SHRTIMER output response to fault protection ⁽¹⁾ 82

Table 4-60. SHRTIMER output response to external 1 to 10(Synchronous mode ⁽¹⁾)..... 82

Table 4-61. SHRTIMER synchronization input / output ⁽¹⁾ 83

Table 4-62. TIMER characteristics ⁽¹⁾ 83

Table 4-63. FWDGT min/max timeout period at 40 kHz (IRC40K) ⁽¹⁾ 84

Table 4-64. WWDGT min-max timeout value at 90 MHz (f_{PCLK1}) ⁽¹⁾ 84

Table 5-1. LQFP144 package dimensions 85

Table 5-2. LQFP100 package dimensions 87

Table 5-3. Package thermal characteristics⁽¹⁾ 89

Table 6-1. Part ordering code for GD32A508xx devices 91

Table 7-1. Revision history 92

1. General description

The GD32A508xx device belongs to the high performance line of GD32 MCU family. It is a new 32-bit general-purpose microcontroller based on the Arm® Cortex®-M33 core. The Cortex®-M33 processor is a 32-bit processor that possesses low interrupt latency and low-cost debug. The characteristics of integrated and advanced make the Cortex®-M33 processor suitable for market products that require microcontrollers with high performance and low power consumption. The processor is based on the ARMv8 architecture and supports a powerful and scalable instruction set including general data processing I/O control tasks, advanced data processing bit field manipulations and DSP.

The GD32A508xx device incorporates the Arm® Cortex®-M33 32-bit processor core operating at up to 180 MHz frequency with Flash accesses 0~4 waiting time to obtain maximum efficiency. It provides up to 512 KB embedded Flash memory and up to 128 KB SRAM memory. An extensive range of enhanced I/Os and peripherals connected to two APB buses. The devices offer two 12-bit ADCs, two DACs, three comparators, up to nine general 16-bit timers, a general 32-bit timer, two basic timers, two PWM advanced timers, as well as standard and advanced communication interfaces: up to three SPIs, three I2Cs, six USARTs, two I2Ss, an USBHS, an ENET and three CANs. Additional peripherals as trigonometric math unit (TMU), super high-resolution Timer (SHRTIMER), EXMC interface, Serial/Quad Parallel Interface (SQPI) are included.

The device operates from a 1.71 to 3.63 V power supply and available in -40 to +105 °C temperature range. Several power saving modes provide the flexibility for maximum optimization between wakeup latency and power consumption, an especially important consideration in low power applications.

The above features make the GD32A508xx devices suitable for a wide range of applications, especially in automotive areas such as BCM, HVAC, BMS, OBC(on-board charger), automotive radar, automotive vision, DC-DC, automotive instrument, IVI(in-vehicle infotainment) and so on.



2. Device overview

2.1. Device information

Table 2-1. GD32A508xx devices features and peripheral list

Part Number	GD32A508xx	
	VET7	ZET7
FLASH (KB)	512	512
SRAM (KB)	128	128
Timers	General timer(16-bit) <small>(2-4,8-13)</small>	9 <small>(2-4,8-13)</small>
	General timer(32-bit) <small>(1)</small>	1 <small>(1)</small>
	Advanced timer(16-bit) <small>(0,7)</small>	2 <small>(0,7)</small>
	SysTick	1
	Basic timer(16-bit) <small>(5-6)</small>	2 <small>(5-6)</small>
	SHRTIMER	1
	Watchdog	2
	RTC	1
Connectivity	USART <small>(0-2,5)</small>	4 <small>(0-2,5)</small>
	UART <small>(3-4)</small>	2 <small>(3-4)</small>
	I2C <small>(0-2)</small>	3 <small>(0-2)</small>
	SPI/I2S <small>(0-2)/(1-2)</small>	3/2 <small>(0-2)/(1-2)</small>
	Ethernet	1
	CAN <small>(0-2)</small>	3 <small>(0-2)</small>
	USBHS	1
GPIO		80
EXMC		1
DAC	Units	1
	Channels	2
CMP		3
TMU		1
ADC	Units	2
	Channels	16
Package		LQFP100
		LQFP144

2.2. Block diagram

Figure 2-1. GD32A508xx block diagram

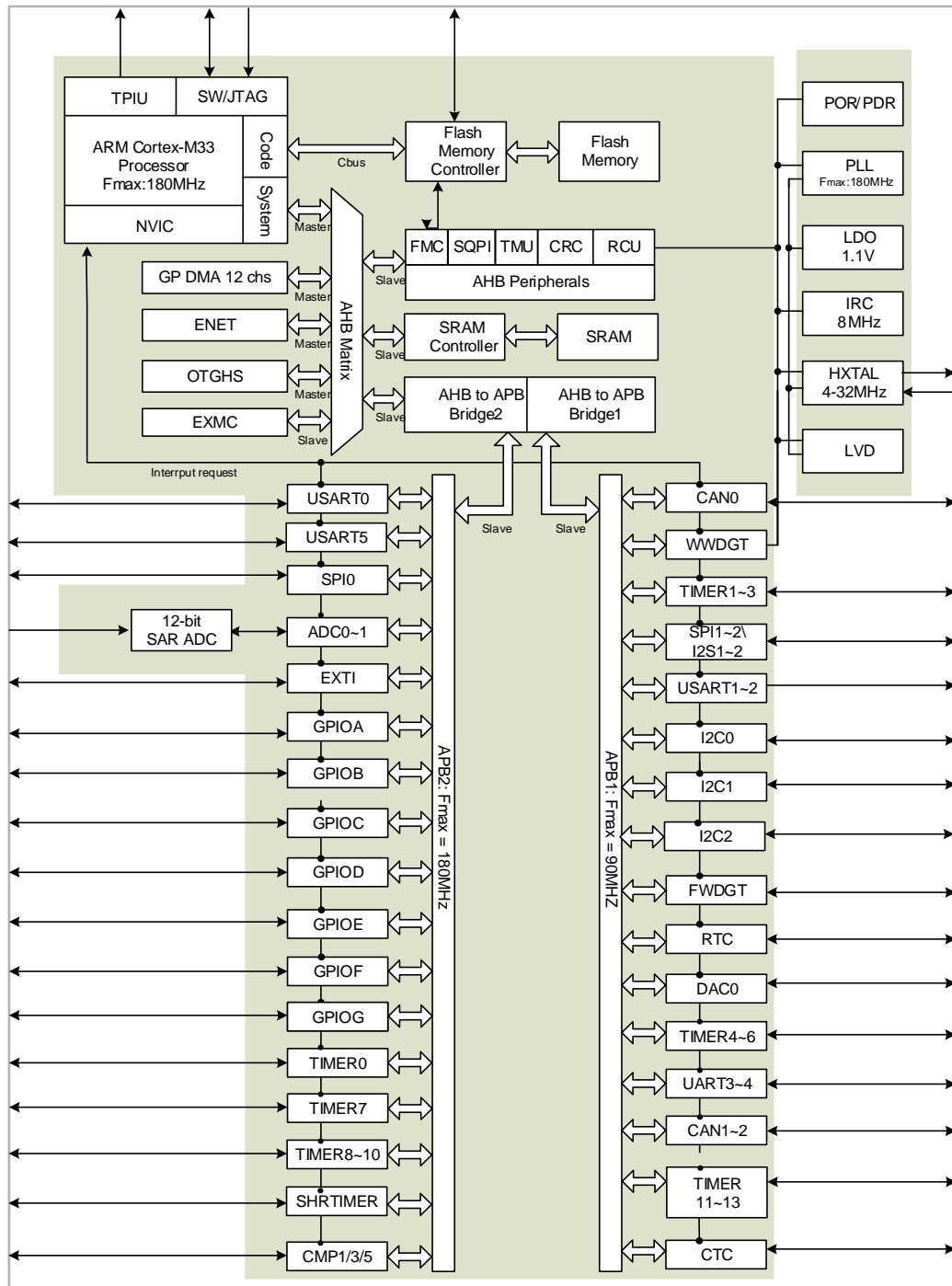

2.3. Pinouts and pin assignment

Figure 2-2. GD32A508Zx LQFP144 pinouts



Figure 2-3. GD32A508Vx LQFP100 pinouts

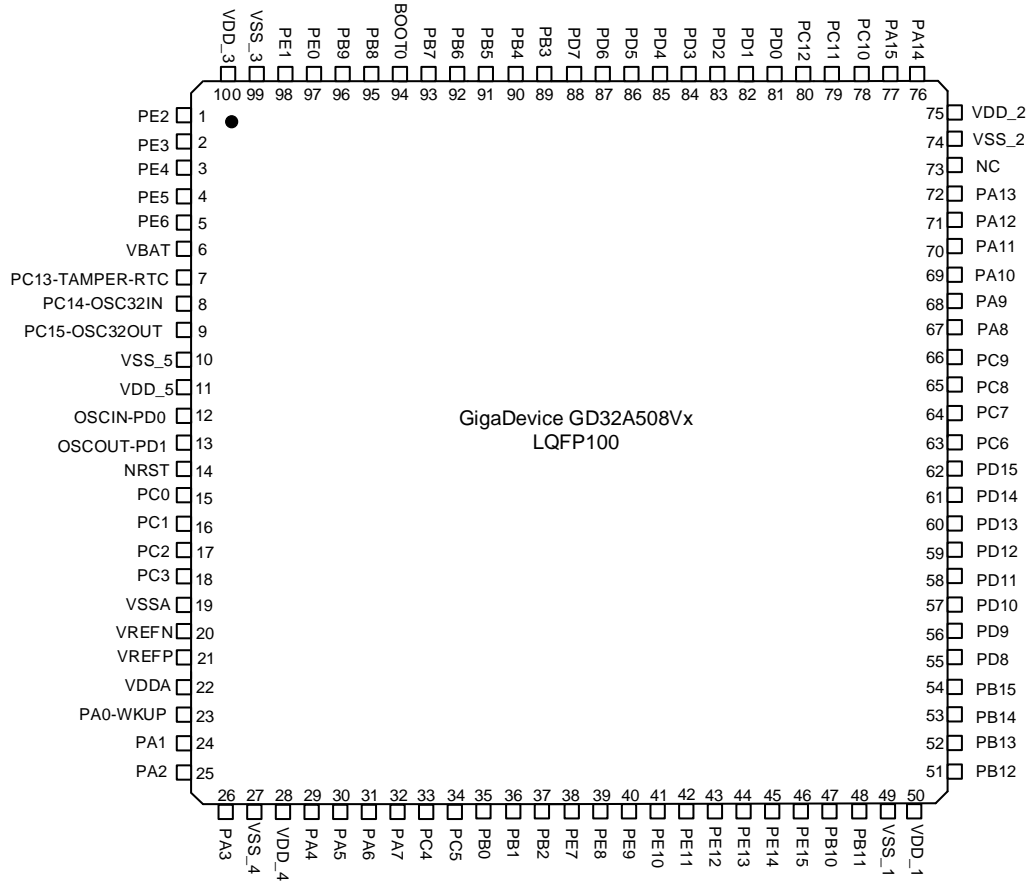

2.4. Memory map

Table 2-2. GD32A508xx memory map

Pre-defined Regions	Bus	Address	Peripherals
External device	AHB3	0xC000 0000 - 0xDFFF FFFF	Reserved
		0xB000 0000 - 0xBFFF FFFF	SQPI_PSRAM(MEM)
		0xA000 1400 - 0xAFFF FFFF	Reserved
		0xA000 1000 - 0xA000 13FF	SQPI_PSRAM(REG)
External RAM	AHB3	0xA000 0000 - 0xA000 0FFF	EXMC - SWREG
		0x9000 0000 - 0x9FFF FFFF	EXMC - PC CARD
		0x7000 0000 - 0x8FFF FFFF	EXMC - NAND
Peripheral	AHB1	0x6000 0000 - 0x6FFF FFFF	EXMC - NOR/PSRAM/SRAM
		0x5000 0000 - 0x5003 FFFF	USBHS
		0x4008 0400 - 0x4FFF FFFF	Reserved
		0x4008 0000 - 0x4008 03FF	TMU
		0x4004 0000 - 0x4007 FFFF	Reserved
		0x4002 BC00 - 0x4003 FFFF	Reserved
		0x4002 B000 - 0x4002 BBFF	Reserved
		0x4002 A000 - 0x4002 AFFF	Reserved
		0x4002 8000 - 0x4002 9FFF	ENET
		0x4002 6800 - 0x4002 7FFF	Reserved
		0x4002 6400 - 0x4002 67FF	Reserved
		0x4002 6000 - 0x4002 63FF	Reserved
		0x4002 5000 - 0x4002 5FFF	Reserved
		0x4002 4000 - 0x4002 4FFF	Reserved
		0x4002 3C00 - 0x4002 3FFF	Reserved
		0x4002 3800 - 0x4002 3BFF	Reserved
		0x4002 3400 - 0x4002 37FF	Reserved
		0x4002 3000 - 0x4002 33FF	CRC
		0x4002 2C00 - 0x4002 2FFF	Reserved
		0x4002 2800 - 0x4002 2BFF	Reserved
		0x4002 2400 - 0x4002 27FF	Reserved
		0x4002 2000 - 0x4002 23FF	FMC
		0x4002 1C00 - 0x4002 1FFF	Reserved
		0x4002 1800 - 0x4002 1BFF	Reserved
		0x4002 1400 - 0x4002 17FF	Reserved
		0x4002 1000 - 0x4002 13FF	RCU
		0x4002 0C00 - 0x4002 0FFF	Reserved
0x4002 0800 - 0x4002 0BFF	Reserved		
0x4002 0400 - 0x4002 07FF	DMA1		

Pre-defined Regions	Bus	Address	Peripherals	
		0x4002 0000 - 0x4002 03FF	DMA0	
		0x4001 8400 - 0x4001 FFFF	Reserved	
		0x4001 8000 - 0x4001 83FF	Reserved	
	APB2		0x4001 7C00 - 0x4001 7FFF	CMP
			0x4001 7800 - 0x4001 7BFF	Reserved
			0x4001 7400 - 0x4001 77FF	SHRTIMER
			0x4001 7000 - 0x4001 73FF	USART5
			0x4001 6C00 - 0x4001 6FFF	Reserved
			0x4001 6800 - 0x4001 6BFF	Reserved
			0x4001 5C00 - 0x4001 67FF	Reserved
			0x4001 5800 - 0x4001 5BFF	Reserved
			0x4001 5400 - 0x4001 57FF	TIMER10
			0x4001 5000 - 0x4001 53FF	TIMER9
			0x4001 4C00 - 0x4001 4FFF	TIMER8
			0x4001 4800 - 0x4001 4BFF	Reserved
			0x4001 4400 - 0x4001 47FF	Reserved
			0x4001 4000 - 0x4001 43FF	Reserved
			0x4001 3C00 - 0x4001 3FFF	Reserved
			0x4001 3800 - 0x4001 3BFF	USART0
			0x4001 3400 - 0x4001 37FF	TIMER7
			0x4001 3000 - 0x4001 33FF	SPI0
			0x4001 2C00 - 0x4001 2FFF	TIMER0
			0x4001 2800 - 0x4001 2BFF	ADC1
			0x4001 2400 - 0x4001 27FF	ADC0
			0x4001 2000 - 0x4001 23FF	GPIOG
			0x4001 1C00 - 0x4001 1FFF	GPIOF
			0x4001 1800 - 0x4001 1BFF	GPIOE
			0x4001 1400 - 0x4001 17FF	GPIOD
			0x4001 1000 - 0x4001 13FF	GPIOC
			0x4001 0C00 - 0x4001 0FFF	GPIOB
			0x4001 0800 - 0x4001 0BFF	GPIOA
			0x4001 0400 - 0x4001 07FF	EXTI
	0x4001 0000 - 0x4001 03FF	AFIO		
APB1		0x4000 CC00 - 0x4000 FFFF	Reserved	
		0x4000 CC00 - 0x4000 CFFF	CAN2	
		0x4000 C800 - 0x4000 CBFF	CTC	
		0x4000 C400 - 0x4000 C7FF	Reserved	
		0x4000 C000 - 0x4000 C3FF	I2C2	
		0x4000 8C00 - 0x4000 BFFF	Reserved	
		0x4000 8800 - 0x4000 8BFF	CAN2SRAM	
		0x4000 8400 - 0x4000 87FF	USBSRAM_B	

Pre-defined Regions	Bus	Address	Peripherals
		0x4000 8000 - 0x4000 BFFF	Reserved
		0x4000 7C00 - 0x4000 7FFF	Reserved
		0x4000 7800 - 0x4000 7BFF	Reserved
		0x4000 7400 - 0x4000 77FF	DAC0
		0x4000 7000 - 0x4000 73FF	PMU
		0x4000 6C00 - 0x4000 6FFF	BKP
		0x4000 6800 - 0x4000 6BFF	CAN1
		0x4000 6400 - 0x4000 67FF	CAN0
		0x4000 6000 - 0x4000 63FF	CAN SRAM 512 bytes
		0x4000 5C00 - 0x4000 5FFF	Reserved
		0x4000 5800 - 0x4000 5BFF	I2C1
		0x4000 5400 - 0x4000 57FF	I2C0
		0x4000 5000 - 0x4000 53FF	UART4
		0x4000 4C00 - 0x4000 4FFF	UART3
		0x4000 4800 - 0x4000 4BFF	USART2
		0x4000 4400 - 0x4000 47FF	USART1
		0x4000 4000 - 0x4000 43FF	I2S2_add
		0x4000 3C00 - 0x4000 3FFF	SPI2/I2S2
		0x4000 3800 - 0x4000 3BFF	SPI1/I2S1
		0x4000 3400 - 0x4000 37FF	I2S1_add
		0x4000 3000 - 0x4000 33FF	FWDGT
		0x4000 2C00 - 0x4000 2FFF	WWDGT
		0x4000 2800 - 0x4000 2BFF	RTC
		0x4000 2400 - 0x4000 27FF	Reserved
		0x4000 2000 - 0x4000 23FF	TIMER13
		0x4000 1C00 - 0x4000 1FFF	TIMER12
		0x4000 1800 - 0x4000 1BFF	TIMER11
		0x4000 1400 - 0x4000 17FF	TIMER6
		0x4000 1000 - 0x4000 13FF	TIMER5
		0x4000 0C00 - 0x4000 0FFF	TIMER4
0x4000 0800 - 0x4000 0BFF	TIMER3		
0x4000 0400 - 0x4000 07FF	TIMER2		
0x4000 0000 - 0x4000 03FF	TIMER1		
SRAM	AHB	0x2007 0000 - 0x3FFF FFFF	Reserved
		0x2006 0000 - 0x2006 FFFF	Reserved
		0x2003 0000 - 0x2005 FFFF	Reserved
		0x2002 0000 - 0x2002 FFFF	Reserved
		0x2000 0000 - 0x2001 FFFF	SRAM
Code	AHB	0x1FFF F810 - 0x1FFF FFFF	Reserved
		0x1FFF F800 - 0x1FFF F80F	Option Bytes
		0x1FFF B000 - 0x1FFF F7FF	Boot loader

Pre-defined Regions	Bus	Address	Peripherals
		0x1FFF 7800 - 0x1FFF AFFF	Reserved
		0x1FFF 7000 - 0x1FFF 77FF	OTP
		0x1FFF 0000 - 0x1FFF 6FFF	Reserved
		0x1FFE C010 - 0x1FFE FFFF	Reserved
		0x1FFE C000 - 0x1FFE C00F	Reserved
		0x1001 0000 - 0x1FFE BFFF	Reserved
		0x1000 0000 - 0x1000 FFFF	Reserved
		0x083C 0000 - 0x0FFF FFFF	Reserved
		0x0830 0000 - 0x083B FFFF	Reserved
		0x0808 0000 - 0x082F FFFF	Reserved
		0x0800 0000 - 0x0807 FFFF	Main Flash
		0x0030 0000 - 0x07FF FFFF	Reserved
		0x0010 0000 - 0x002F FFFF	Reserved
		0x0008 0000 - 0x000F FFFF	Reserved
		0x0002 0000 - 0x0007 FFFF	Aliased to Main Flash
		0x0000 0000 - 0x0001 FFFF	or Boot loader

2.5. Clock tree

Figure 2-4. GD32A508xx clock tree

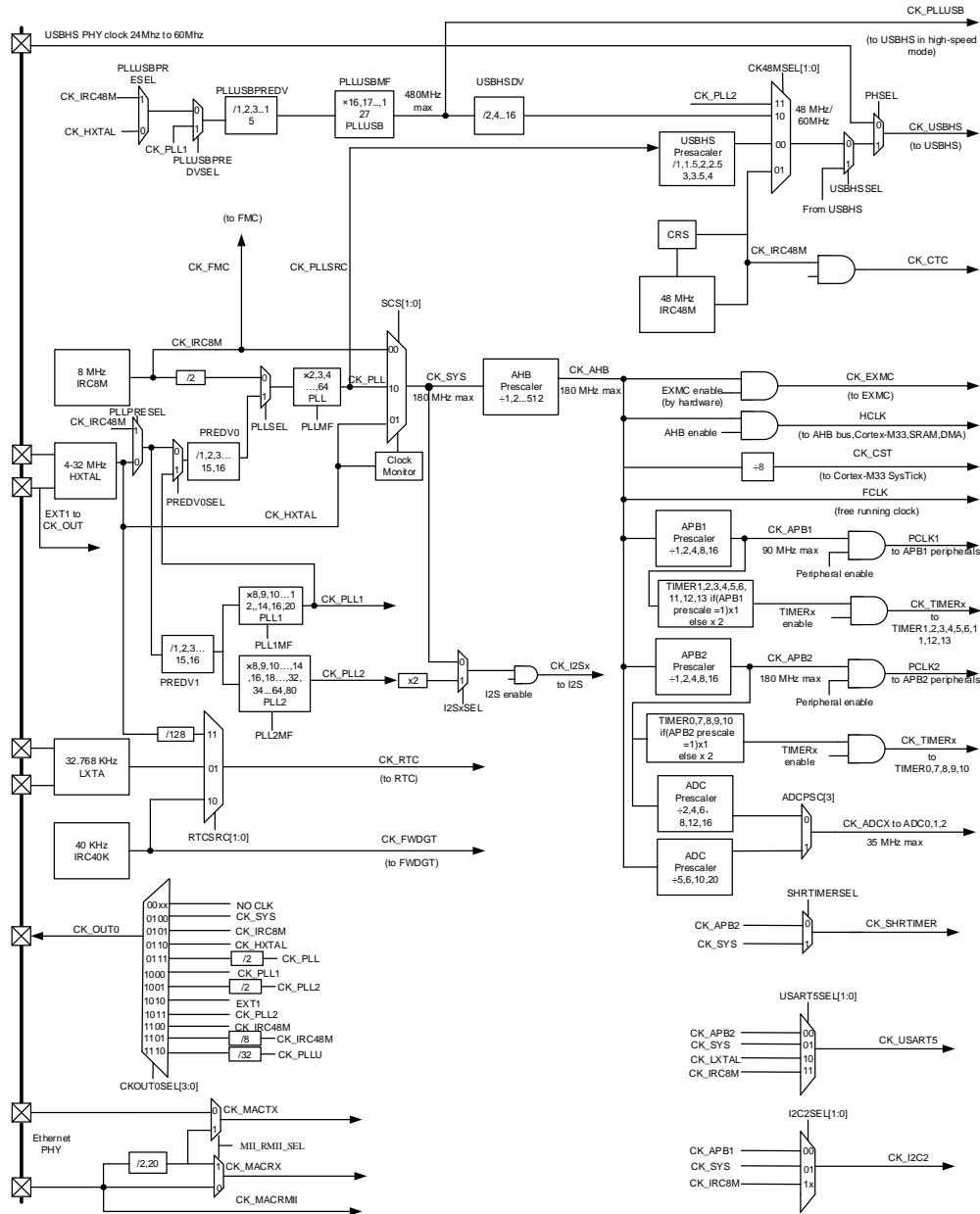

Note:

The TIMERS are clocked by the clock divided from CK_APB2 and CK_APB1. The frequency of TIMERS clock is equal to CK_APBx (APB prescaler is 1), twice the CK_APBx (APB prescaler is not 1).

Legend:

- HXTAL: High speed crystal oscillator
- LXTAL: Low speed crystal oscillator
- IRC8M: Internal 8M RC oscillator
- IRC40K: Internal 40K RC oscillator
- IRC48M: Internal 48M RC oscillator

2.6. Pin definitions

2.6.1. GD32A508Zx LQFP144 pin definitions

Table 2-3. GD32A508Zx LQFP144 pin definitions

Pin Name	Pins	Pin Type ⁽¹⁾	I/O Level ⁽²⁾	Functions description ⁽³⁾
PE2	1	I/O	5VT	Default: PE2 Alternate2: EXMC_A23
PE3	2	I/O	5VT	Default: PE3 Alternate2: EXMC_A19
PE4	3	I/O	5VT	Default: PE4 Alternate2: EXMC_A20
PE5	4	I/O	5VT	Default: PE5 Alternate2: EXMC_A21 Remap: TIMER8_CH0
PE6	5	I/O	5VT	Default: PE6 Alternate2: EXMC_A22, WKUP2 Remap: TIMER8_CH1
VBAT	6	P		Default: VBAT
PC13- TAMPER- RTC	7	I/O		Default: PC13 Alternate2: TAMPER-RTC, WKUP1
PC14- OSC32IN	8	I/O		Default: PC14 Alternate2: OSC32IN
PC15- OSC32OUT	9	I/O		Default: PC15 Alternate2: OSC32OUT
PF0	10	I/O	5VT	Default: PF0 Alternate2: EXMC_A0, SQPI_D0 Remap: CTC_SYNC
PF1	11	I/O	5VT	Default: PF1 Alternate2: EXMC_A1
PF2	12	I/O	5VT	Default: PF2 Alternate2: EXMC_A2, SQPI_D2
PF3	13	I/O	5VT	Default: PF3 Alternate2: EXMC_A3
PF4	14	I/O	5VT	Default: PF4 Alternate2: EXMC_A4, SQPI_D1
PF5	15	I/O	5VT	Default: PF5 Alternate2: EXMC_A5
VSS_5	16	P		Default: VSS_5
VDD_5	17	P		Default: VDD_5
PF6	18	I/O		Default: PF6

Pin Name	Pins	Pin Type ⁽¹⁾	I/O Level ⁽²⁾	Functions description ⁽³⁾
				Alternate2: EXMC_NIORD, SQPI_CSN Remap: TIMER9_CH0
PF7	19	I/O		Default: PF7 Alternate2: EXMC_NREG Remap: TIMER10_CH0
PF8	20	I/O		Default: PF8 Alternate2: EXMC_NIOWR, WKUP7, SQPI_CLK Remap: TIMER12_CH0
PF9	21	I/O		Default: PF9 Alternate2: EXMC_CD Remap: TIMER13_CH0
PF10	22	I/O		Default: PF10 Alternate2: EXMC_INTR, SQPI_D3
OSCIN-PD0	23	I		Default: OSCIN Remap: PD0
OSCOU-PD1	24	O		Default: OSCOUT Remap: PD1
NRST	25	I/O		Default: NRST
PC0	26	I/O		Default: PC0 Alternate1: USBHS_ULPI_STP Alternate2: ADC01_IN10
PC1	27	I/O		Default: PC1 Alternate2: ADC01_IN11, ETH_MII_MDC, ETH_RMII_MDC
PC2	28	I/O		Default: PC2 Alternate1: USBHS_ULPI_DIR, I2S1_ADD_SD Alternate2: ADC01_IN12, ETH_MII_TXD2
PC3	29	I/O		Default: PC3 Alternate1: USBHS_ULPI_NXT Alternate2: ADC01_IN13, ETH_MII_TX_CLK
VSSA	30	P		Default: VSSA
VREFN	31	P		Default: VREFN
VREFP	32	P		Default: VREFP
VDDA	33	P		Default: VDDA
PA0-WKUP	34	I/O		Default: PA0 Alternate2: WKUP0, USART1_CTS, ADC01_IN0, TIMER1_CH0, TIMER1_ETI, TIMER4_CH0, TIMER7_ETI, ETH_MII_CRS
PA1	35	I/O		Default: PA1 Alternate2: USART1_RTS, ADC01_IN1, TIMER4_CH1, TIMER1_CH1, ETH_MII_RX_CLK, ETH_RMII_REF_CLK
PA2	36	I/O		Default: PA2 Alternate1: CMP1_OUT Alternate2: USART1_TX, TIMER4_CH2, ADC01_IN2,

Pin Name	Pins	Pin Type ⁽¹⁾	I/O Level ⁽²⁾	Functions description ⁽³⁾
				TIMER8_CH0, TIMER1_CH2, ETH_MII_MDIO, ETH_RMII_MDIO, SPI0_IO2, WKUP3, CMP1_IM6
PA3	37	I/O		Default: PA3 Alternate1: USBHS_ULPI_D0 Alternate2: USART1_RX, TIMER4_CH3, ADC01_IN3, TIMER1_CH3, TIMER8_CH1, ETH_MII_COL, SPI0_IO3
VSS_4	38	P		Default: VSS_4
VDD_4	39	P		Default: VDD_4
PA4	40	I/O		Default: PA4 Alternate2: SPI0_NSS, USART1_CK, DAC0_OUT0, ADC01_IN4, CMP1_IM4, CMP3_IM4, CMP5_IM4 Remap: SPI2_NSS, I2S2_WS
PA5	41	I/O		Default: PA5 Alternate1: USBHS_ULPI_CK Alternate2: SPI0_SCK, ADC01_IN5, DAC0_OUT1, CMP1_IM5, CMP3_IM5, CMP5_IM5
PA6	42	I/O		Default: PA6 Alternate2: SPI0_MISO, TIMER7_BRKIN, ADC01_IN6, TIMER2_CH0, TIMER12_CH0 Remap: TIMER0_BRKIN
PA7	43	I/O		Default: PA7 Alternate2: SPI0_MOSI, TIMER7_CH0_ON, ADC01_IN7, TIMER2_CH1, TIMER13_CH0, ETH_MII_RX_DV, ETH_RMII_CRS_DV, CMP1_IP Remap: TIMER0_CH0_ON
PC4	44	I/O		Default: PC4 Alternate2: ADC01_IN14, ETH_MII_RXD0, ETH_RMII_RXD0
PC5	45	I/O		Default: PC5 Alternate2: ADC01_IN15, ETH_MII_RXD1, ETH_RMII_RXD1, WKUP4
PB0	46	I/O		Default: PB0 Alternate1: USBHS_ULPI_D1 Alternate2: ADC01_IN8, TIMER2_CH2, TIMER7_CH1_ON, ETH_MII_RXD2, CMP3_IP Remap: TIMER0_CH1_ON
PB1	47	I/O		Default: PB1 Alternate1: CMP3_OUT, USBHS_ULPI_D2, SHRTIMER_SCOUT Alternate2: ADC01_IN9, TIMER2_CH3, TIMER7_CH2_ON, ETH_MII_RXD3 Remap: TIMER0_CH2_ON
PB2	48	I/O	5VT	Default: PB2, BOOT1

Pin Name	Pins	Pin Type ⁽¹⁾	I/O Level ⁽²⁾	Functions description ⁽³⁾
				Alternate1: USBHS_ULPI_D4, SHRTIMER_SCIN Alternate2: CMP3_IM7
PF11	49	I/O	5VT	Default: PF11 Alternate2: EXMC_NIOS16
PF12	50	I/O	5VT	Default: PF12 Alternate2: EXMC_A6
VSS_6	51	P		Default: VSS_6
VDD_6	52	P		Default: VDD_6
PF13	53	I/O	5VT	Default: PF13 Alternate2: EXMC_A7
PF14	54	I/O	5VT	Default: PF14 Alternate2: EXMC_A8
PF15	55	I/O	5VT	Default: PF15 Alternate2: EXMC_A9
PG0	56	I/O	5VT	Default: PG0 Alternate2: EXMC_A10
PG1	57	I/O	5VT	Default: PG1 Alternate2: EXMC_A11
PE7	58	I/O	5VT	Default: PE7 Alternate2: EXMC_D4 Remap: TIMER0_ETI
PE8	59	I/O	5VT	Default: PE8 Alternate1: CMP1_OUT Alternate2: EXMC_D5 Remap: TIMER0_CH0_ON
PE9	60	I/O	5VT	Default: PE9 Alternate1: CMP3_OUT Alternate2: EXMC_D6 Remap: TIMER0_CH0
VSS_7	61	P		Default: VSS_7
VDD_7	62	P		Default: VDD_7
PE10	63	I/O	5VT	Default: PE10 Alternate1: CMP5_OUT Alternate2: EXMC_D7 Remap: TIMER0_CH1_ON
PE11	64	I/O	5VT	Default: PE11 Alternate1: CMP5_OUT Alternate2: EXMC_D8 Remap: TIMER0_CH1
PE12	65	I/O	5VT	Default: PE12 Alternate1: CMP3_OUT Alternate2: EXMC_D9 Remap: TIMER0_CH2_ON

Pin Name	Pins	Pin Type ⁽¹⁾	I/O Level ⁽²⁾	Functions description ⁽³⁾
PE13	66	I/O	5VT	Default: PE13 Alternate1: CMP1_OUT Alternate2: EXMC_D10 Remap: TIMER0_CH2
PE14	67	I/O	5VT	Default: PE14 Alternate2: EXMC_D11 Remap: TIMER0_CH3
PE15	68	I/O	5VT	Default: PE15 Alternate2: EXMC_D12 Remap: TIMER0_BRKIN
PB10	69	I/O	5VT	Default: PB10 Alternate1: CAN2_RX, USBHS_ULPI_D3, SHRTIMER_FLT2 Alternate2: I2C1_SCL, USART2_TX, ETH_MII_RX_ER Remap: TIMER1_CH2
PB11	70	I/O	5VT	Default: PB11 Alternate1: CAN2_TX, USBHS_ULPI_D4, SHRTIMER_FLT3 Alternate2: I2C1_SDA, USART2_RX, ETH_MII_TX_EN, ETH_RMII_TX_EN, CMP5_IP Remap: TIMER1_CH3
VSS_1	71	P		Default: VSS_1
VDD_1	72	P		Default: VDD_1
PB12	73	I/O	5VT	Default: PB12 Alternate1: USBHS_ULPI_D5, SHRTIMER_ST2CH0 Alternate2: SPI1_NSS, I2S1_WS, I2C1_SMBA, USART2_CK, TIMER0_BRKIN, CAN1_RX, ETH_MII_TXD0, ETH_RMII_TXD0
PB13	74	I/O	5VT	Default: PB13 Alternate1: USBHS_ULPI_D6, SHRTIMER_ST2CH1 Alternate2: SPI1_SCK, I2S1_CK, USART2_CTS, TIMER0_CH0_ON, CAN1_TX, ETH_MII_TXD1, ETH_RMII_TXD1, I2C1_TXFRAME
PB14	75	I/O	5VT	Default: PB14 Alternate1: SHRTIMER_ST3CH0, I2S1_ADD_SD Alternate2: SPI1_MISO, USART2_RTS, TIMER0_CH1_ON, TIMER11_CH0
PB15	76	I/O	5VT	Default: PB15 Alternate1: SHRTIMER_ST3CH1 Alternate2: SPI1_MOSI, TIMER0_CH2_ON, I2S1_SD, TIMER11_CH1, WKUP6, CMP5_IM7
PD8	77	I/O	5VT	Default: PD8 Alternate2: EXMC_D13

Pin Name	Pins	Pin Type ⁽¹⁾	I/O Level ⁽²⁾	Functions description ⁽³⁾
				Remap: USART2_TX, ETH_MII_RX_DV, ETH_RMII_CRD_DV
PD9	78	I/O	5VT	Default: PD9 Alternate2: EXMC_D14 Remap: USART2_RX, ETH_MII_RXD0, ETH_RMII_RXD0
PD10	79	I/O	5VT	Default: PD10 Alternate2: EXMC_D15 Remap: USART2_CK, ETH_MII_RXD1, ETH_RMII_RXD1
PD11	80	I/O	5VT	Default: PD11 Alternate2: EXMC_A16/EXMC_CLE Remap: USART2_CTS, ETH_MII_RXD2
PD12	81	I/O	5VT	Default: PD12 Alternate2: EXMC_A17/EXMC_ALE Remap: TIMER3_CH0, USART2_RTS, ETH_MII_RXD3
PD13	82	I/O	5VT	Default: PD13 Alternate2: EXMC_A18 Remap: TIMER3_CH1
VSS_8	83	P		Default: VSS_8
VDD_8	84	P		Default: VDD_8
PD14	85	I/O	5VT	Default: PD14 Alternate2: EXMC_D0 Remap: TIMER3_CH2
PD15	86	I/O	5VT	Default: PD15 Alternate2: EXMC_D1 Remap: TIMER3_CH3, CTC_SYNC
PG2	87	I/O	5VT	Default: PG2 Alternate2: EXMC_A12
PG3	88	I/O	5VT	Default: PG3 Alternate2: EXMC_A13
PG4	89	I/O	5VT	Default: PG4 Alternate2: EXMC_A14, SQPI_CSN
PG5	90	I/O	5VT	Default: PG5 Alternate2: EXMC_A15
PG6	91	I/O	5VT	Default: PG6 Alternate1: SHRTIMER_ST4CH0 Alternate2: EXMC_INT1, SQPI_D1
PG7	92	I/O	5VT	Default: PG7 Alternate1: SHRTIMER_ST4CH1, USART5_CK Alternate2: EXMC_INT2
PG8	93	I/O	5VT	Default: PG8 Alternate2: SQPI_D2
VSS_9	94	P		Default: VSS_9
VDD_9	95	P		Default: VDD_9

Pin Name	Pins	Pin Type ⁽¹⁾	I/O Level ⁽²⁾	Functions description ⁽³⁾
PC6	96	I/O	5VT	Default: PC6 Alternate1: SHRTIMER_EXEV9, CMP5_OUT, USART5_TX Alternate2: I2S1_MCK, TIMER7_CH0 Remap: TIMER2_CH0
PC7	97	I/O	5VT	Default: PC7 Alternate1: SHRTIMER_FLT4, USART5_RX Alternate2: I2S2_MCK, TIMER7_CH1 Remap: TIMER2_CH1
PC8	98	I/O	5VT	Default: PC8 Alternate1: SHRTIMER_ST4CH0, USART5_CK Alternate2: TIMER7_CH2 Remap: TIMER2_CH2
PC9	99	I/O	5VT	Default: PC9 Alternate1: SHRTIMER_ST4CH1, I2C2_SDA Alternate2: TIMER7_CH3 Remap: TIMER2_CH3
PA8	100	I/O	5VT	Default: PA8 Alternate1: SHRTIMER_ST0CH0, I2C2_SCL Alternate2: USART0_CK, TIMER0_CH0, CK_OUT, USBHS_SOF, CTC_SYNC
PA9	101	I/O	5VT	Default: PA9 Alternate1: CAN2_RX, SHRTIMER_ST0CH1, I2C2_SMBA Alternate2: USART0_TX, TIMER0_CH1, USBHS_VBUS
PA10	102	I/O	5VT	Default: PA10 Alternate1: CAN2_TX, CMP5_OUT, SHRTIMER_ST1CH0 Alternate2: USART0_RX, TIMER0_CH2, USBHS_ID
PA11	103	I/O		Default: PA11 Alternate1: SHRTIMER_ST1CH1, USART5_TX Alternate2: USART0_CTS, CAN0_RX, TIMER0_CH3, USBHS_DM
PA12	104	I/O		Default: PA12 Alternate1: CMP1_OUT, SHRTIMER_FLT0, USART5_RX Alternate2: USART0_RTS, CAN0_TX, TIMER0_ETI, USBHS_DP
PA13	105	I/O	5VT	Default: JTMS, SWDIO Remap: PA13
NC	106			-
VSS_2	107	P		Default: VSS_2
VDD_2	108	P		Default: VDD_2
PA14	109	I/O	5VT	Default: JTCK, SWCLK Remap: PA14
PA15	110	I/O	5VT	Default: JTDI Alternate1: SHRTIMER_FLT1

Pin Name	Pins	Pin Type ⁽¹⁾	I/O Level ⁽²⁾	Functions description ⁽³⁾
				Alternate2: SPI2_NSS, I2S2_WS Remap: TIMER1_CH0, TIMER1_ETI, PA15, SPI0_NSS
PC10	111	I/O	5VT	Default: PC10 Alternate1: I2C2_SCL Alternate2: UART3_TX Remap: USART2_TX, SPI2_SCK, I2S2_CK
PC11	112	I/O	5VT	Default: PC11 Alternate1: SHRTIMER_EXEV1, I2S2_ADD_SD Alternate2: UART3_RX Remap: USART2_RX, SPI2_MISO
PC12	113	I/O	5VT	Default: PC12 Alternate1: SHRTIMER_EXEV0 Alternate2: UART4_TX Remap: USART2_CK, SPI2_MOSI, I2S2_SD
PD0	114	I/O	5VT	Default: PD0 Alternate2: EXMC_D2 Remap: CAN0_RX
PD1	115	I/O	5VT	Default: PD1 Alternate2: EXMC_D3 Remap: CAN0_TX
PD2	116	I/O	5VT	Default: PD2 Alternate2: TIMER2_ETI, UART4_RX
PD3	117	I/O	5VT	Default: PD3 Alternate2: EXMC_CLK Remap: USART1_CTS
PD4	118	I/O	5VT	Default: PD4 Alternate1: SHRTIMER_FLT2 Alternate2: EXMC_NOE Remap: USART1_RTS
PD5	119	I/O	5VT	Default: PD5 Alternate1: SHRTIMER_EXEV2 Alternate2: EXMC_NWE Remap: USART1_TX
VSS_10	120			Default: VSS_10
VDD_10	121			Default: VDD_10
PD6	122	I/O	5VT	Default: PD6 Alternate2: EXMC_NWAIT Remap: USART1_RX
PD7	123	I/O	5VT	Default: PD7 Alternate2: EXMC_NE0, EXMC_NCE1 Remap: USART1_CK
PG9	124	I/O	5VT	Default: PG9 Alternate1: USART5_RX

Pin Name	Pins	Pin Type ⁽¹⁾	I/O Level ⁽²⁾	Functions description ⁽³⁾
				Alternate2: EXMC_NE1, EXMC_NCE2
PG10	125	I/O	5VT	Default: PG10 Alternate1: SHRTIMER_FLT4 Alternate2: EXMC_NCE3_0, EXMC_NE2
PG11	126	I/O	5VT	Default: PG11 Alternate1: SHRTIMER_EXEV3 Alternate2: EXMC_NCE3_1
PG12	127	I/O	5VT	Default: PG12 Alternate1: SHRTIMER_EXEV4 Alternate2: EXMC_NE3
PG13	128	I/O	5VT	Default: PG13 Alternate1: SHRTIMER_EXEV9 Alternate2: EXMC_A24
PG14	129	I/O	5VT	Default: PG14 Alternate1: USART5_TX Alternate2: EXMC_A25
VSS_11	130	P		Default: VSS_11
VDD_11	131	P		Default: VDD_11
PG15	132	I/O	5VT	Default: PG15
PB3	133	I/O	5VT	Default: JTDO Alternate1: SHRTIMER_SCOUT, SHRTIMER_EXEV8 Alternate2: SPI2_SCK, I2S2_CK Remap: TIMER1_CH1, PB3, SPI0_SCK, TRACESWO
PB4	134	I/O	5VT	Default: NJTRST Alternate1: SHRTIMER_EXEV6, I2C2_SDA, I2S2_ADD_SD Alternate2: SPI2_MISO, I2C0_TXFRAME Remap: TIMER2_CH0, PB4, SPI0_MISO
PB5	135	I/O		Default: PB5 Alternate1: USBHS_ULPI_D7, SHRTIMER_EXEV5, I2C2_SCL Alternate2: I2C0_SMBA, SPI2_MOSI, I2S2_SD, ETH_MII_PPS_OUT, ETH_RMII_PPS_OUT, WKUP5 Remap: TIMER2_CH1, SPI0_MOSI, CAN1_RX
PB6	136	I/O	5VT	Default: PB6 Alternate1: SHRTIMER_SCIN, SHRTIMER_EXEV3 Alternate2: I2C0_SCL, TIMER3_CH0 Remap: USART0_TX, CAN1_TX, SPI0_IO2
PB7	137	I/O	5VT	Default: PB7 Alternate1: SHRTIMER_EXEV2 Alternate2: I2C0_SDA, TIMER3_CH1, EXMC_NADV Remap: USART0_RX, SPI0_IO3
BOOT0	138	I		Default: BOOT0

Pin Name	Pins	Pin Type ⁽¹⁾	I/O Level ⁽²⁾	Functions description ⁽³⁾
PB8	139	I/O	5VT	Default: PB8 Alternate1: SHRTIMER_EXEV7, I2C2_SDA Alternate2: TIMER3_CH2, TIMER9_CH0, ETH_MII_TXD3 Remap: I2C0_SCL, CAN0_RX
PB9	140	I/O	5VT	Default: PB9 Alternate1: CMP1_OUT, SHRTIMER_EXEV4 Alternate2: TIMER3_CH3, TIMER10_CH0 Remap: I2C0_SDA, CAN0_TX
PE0	141	I/O	5VT	Default: PE0 Alternate1: CAN2_RX, SHRTIMER_SCIN Alternate2: TIMER3_ETI, EXMC_NBL0
PE1	142	I/O	5VT	Default: PE1 Alternate1: CAN2_TX, SHRTIMER_SCOUT Alternate2: EXMC_NBL1
VSS_3	143	P		Default: VSS_3
VDD_3	144	P		Default: VDD_3

Notes:

(1) Type: I = input, O = output, P = power.

(2) I/O Level: 5VT = 5 V tolerant.

(3) Alternate1: The specified function can be mapped to the specific pin by configuring AFIO_PCFA ~ AFIO_PCFG registers.

Alternate2: These functions can be enabled with correct GPIO and function module mode configurations.

Remap: A group of the specified module functions can be mapped to the specified pins by configuring AFIO_PCF0 ~ AFIO_PCF1 registers.

2.6.2. GD32A508Vx LQFP100 pin definitions

Table 2-4. GD32A508Vx LQFP100 pin definitions

Pin Name	Pins	Pin Type ⁽¹⁾	I/O Level ⁽²⁾	Functions description ⁽³⁾
PE2	1	I/O	5VT	Default: PE2 Alternate2: EXMC_A23
PE3	2	I/O	5VT	Default: PE3 Alternate2: EXMC_A19
PE4	3	I/O	5VT	Default: PE4 Alternate2: EXMC_A20
PE5	4	I/O	5VT	Default: PE5 Alternate2: EXMC_A21 Remap: TIMER8_CH0
PE6	5	I/O	5VT	Default: PE6 Alternate2: EXMC_A22, WKUP2 Remap: TIMER8_CH1
VBAT	6	P		Default: VBAT
PC13- TAMPER- RTC	7	I/O		Default: PC13 Alternate2: TAMPER-RTC, WKUP1
PC14- OSC32IN	8	I/O		Default: PC14 Alternate2: OSC32IN
PC15- OSC32OUT	9	I/O		Default: PC15 Alternate2: OSC32OUT
VSS_5	10	P		Default: VSS_5
VDD_5	11	P		Default: VDD_5
OSCIN-PD0	12	I		Default: OSCIN Remap: PD0
OSCOUT- PD1	13	O		Default: OSCOUT Remap: PD1
NRST	14	I/O		Default: NRST
PC0	15	I/O		Default: PC0 Alternate1: USBHS_ULPI_STP Alternate2: ADC01_IN10
PC1	16	I/O		Default: PC1 Alternate2: ADC01_IN11, ETH_MII_MDC, ETH_RMII_MDC
PC2	17	I/O		Default: PC2 Alternate1: USBHS_ULPI_DIR, I2S1_ADD_SD Alternate2: ADC01_IN12, ETH_MII_TXD2
PC3	18	I/O		Default: PC3 Alternate1: USBHS_ULPI_NXT Alternate2: ADC01_IN13, ETH_MII_TX_CLK

Pin Name	Pins	Pin Type ⁽¹⁾	I/O Level ⁽²⁾	Functions description ⁽³⁾
VSSA	19	P		Default: VSSA
VREFN	20	P		Default: VREFN
VREFP	21	P		Default: VREFP
VDDA	22	P		Default: VDDA
PA0-WKUP	23	I/O		Default: PA0 Alternate2: WKUP0, USART1_CTS, ADC01_IN0, TIMER1_CH0, TIMER1_ETI, TIMER4_CH0, TIMER7_ETI, ETH_MII_CRS
PA1	24	I/O		Default: PA1 Alternate2: USART1_RTS, ADC01_IN1, TIMER4_CH1, TIMER1_CH1, ETH_MII_RX_CLK, ETH_RMII_REF_CLK
PA2	25	I/O		Default: PA2 Alternate1: CMP1_OUT Alternate2: USART1_TX, TIMER4_CH2, ADC01_IN2, TIMER8_CH0, TIMER1_CH2, ETH_MII_MDIO, ETH_RMII_MDIO, SPI0_IO2, WKUP3, CMP1_IM6
PA3	26	I/O		Default: PA3 Alternate1: USBHS_ULPI_D0 Alternate2: USART1_RX, TIMER4_CH3, ADC01_IN3, TIMER1_CH3, TIMER8_CH1, ETH_MII_COL, SPI0_IO3
VSS_4	27	P		Default: VSS_4
VDD_4	28	P		Default: VDD_4
PA4	29	I/O		Default: PA4 Alternate2: SPI0_NSS, USART1_CK, DAC0_OUT0, ADC01_IN4, CMP1_IM4, CMP3_IM4, CMP5_IM4 Remap: SPI2_NSS, I2S2_WS
PA5	30	I/O		Default: PA5 Alternate1: USBHS_ULPI_CK Alternate2: SPI0_SCK, ADC01_IN5, DAC0_OUT1, CMP1_IM5, CMP3_IM5, CMP5_IM5
PA6	31	I/O		Default: PA6 Alternate2: SPI0_MISO, TIMER7_BRKIN, ADC01_IN6, TIMER2_CH0, TIMER12_CH0 Remap: TIMER0_BRKIN
PA7	32	I/O		Default: PA7 Alternate2: SPI0_MOSI, TIMER7_CH0_ON, ADC01_IN7, TIMER2_CH1, TIMER13_CH0, ETH_MII_RX_DV, ETH_RMII_CRS_DV, CMP1_IP Remap: TIMER0_CH0_ON
PC4	33	I/O		Default: PC4 Alternate2: ADC01_IN14, ETH_MII_RXD0, ETH_RMII_RXD0
PC5	34	I/O		Default: PC5

Pin Name	Pins	Pin Type ⁽¹⁾	I/O Level ⁽²⁾	Functions description ⁽³⁾
				Alternate2: ADC01_IN15, ETH_MII_RXD1, ETH_RMII_RXD1, WKUP4
PB0	35	I/O		Default: PB0 Alternate1: USBHS_ULPI_D1 Alternate2: ADC01_IN8, TIMER2_CH2, TIMER7_CH1_ON, ETH_MII_RXD2, CMP3_IP Remap: TIMER0_CH1_ON
PB1	36	I/O		Default: PB1 Alternate1: CMP3_OUT, USBHS_ULPI_D2, SHRTIMER_SCOU Alternate2: ADC01_IN9, TIMER2_CH3, TIMER7_CH2_ON, ETH_MII_RXD3 Remap: TIMER0_CH2_ON
PB2	37	I/O	5VT	Default: PB2, BOOT1 Alternate1: USBHS_ULPI_D4, SHRTIMER_SCIN Alternate2: CMP3_IM7
PE7	38	I/O	5VT	Default: PE7 Alternate2: EXMC_D4 Remap: TIMER0_ETI
PE8	39	I/O	5VT	Default: PE8 Alternate1: CMP1_OUT Alternate2: EXMC_D5 Remap: TIMER0_CH0_ON
PE9	40	I/O	5VT	Default: PE9 Alternate1: CMP3_OUT Alternate2: EXMC_D6 Remap: TIMER0_CH0
PE10	41	I/O	5VT	Default: PE10 Alternate1: CMP5_OUT Alternate2: EXMC_D7 Remap: TIMER0_CH1_ON
PE11	42	I/O	5VT	Default: PE11 Alternate1: CMP5_OUT Alternate2: EXMC_D8 Remap: TIMER0_CH1
PE12	43	I/O	5VT	Default: PE12 Alternate1: CMP3_OUT Alternate2: EXMC_D9 Remap: TIMER0_CH2_ON
PE13	44	I/O	5VT	Default: PE13 Alternate1: CMP1_OUT Alternate2: EXMC_D10 Remap: TIMER0_CH2
PE14	45	I/O	5VT	Default: PE14

Pin Name	Pins	Pin Type ⁽¹⁾	I/O Level ⁽²⁾	Functions description ⁽³⁾
				Alternate2: EXMC_D11 Remap: TIMER0_CH3
PE15	46	I/O	5VT	Default: PE15 Alternate2: EXMC_D12 Remap: TIMER0_BRKIN
PB10	47	I/O	5VT	Default: PB10 Alternate1: CAN2_RX, USBHS_ULPI_D3, SHRTIMER_FLT2 Alternate2: I2C1_SCL, USART2_TX, ETH_MII_RX_ER Remap: TIMER1_CH2
PB11	48	I/O	5VT	Default: PB11 Alternate1: CAN2_TX, USBHS_ULPI_D4, SHRTIMER_FLT3 Alternate2: I2C1_SDA, USART2_RX, ETH_MII_TX_EN, ETH_RMII_TX_EN, CMP5_IP Remap: TIMER1_CH3
VSS_1	49	P		Default: VSS_1
VDD_1	50	P		Default: VDD_1
PB12	51	I/O	5VT	Default: PB12 Alternate1: USBHS_ULPI_D5, SHRTIMER_ST2CH0 Alternate2: SPI1_NSS, I2S1_WS, I2C1_SMBA, USART2_CK, TIMER0_BRKIN, CAN1_RX, ETH_MII_TXD0, ETH_RMII_TXD0
PB13	52	I/O	5VT	Default: PB13 Alternate1: USBHS_ULPI_D6, SHRTIMER_ST2CH1 Alternate2: SPI1_SCK, I2S1_CK, USART2_CTS, TIMER0_CH0_ON, CAN1_TX, ETH_MII_TXD1, ETH_RMII_TXD1, I2C1_TXFRAME
PB14	53	I/O	5VT	Default: PB14 Alternate1: SHRTIMER_ST3CH0, I2S1_ADD_SD Alternate2: SPI1_MISO, USART2_RTS, TIMER0_CH1_ON, TIMER11_CH0
PB15	54	I/O	5VT	Default: PB15 Alternate1: SHRTIMER_ST3CH1 Alternate2: SPI1_MOSI, TIMER0_CH2_ON, I2S1_SD, TIMER11_CH1, WKUP6, CMP5_IM7
PD8	55	I/O	5VT	Default: PD8 Alternate2: EXMC_D13 Remap: USART2_TX, ETH_MII_RX_DV, ETH_RMII_CRS_DV
PD9	56	I/O	5VT	Default: PD9 Alternate2: EXMC_D14 Remap: USART2_RX, ETH_MII_RXD0,

Pin Name	Pins	Pin Type ⁽¹⁾	I/O Level ⁽²⁾	Functions description ⁽³⁾
				ETH_RMII_RXD0
PD10	57	I/O	5VT	Default: PD10 Alternate2: EXMC_D15 Remap: USART2_CK, ETH_MII_RXD1, ETH_RMII_RXD1
PD11	58	I/O	5VT	Default: PD11 Alternate2: EXMC_A16/EXMC_CLE Remap: USART2_CTS, ETH_MII_RXD2
PD12	59	I/O	5VT	Default: PD12 Alternate2: EXMC_A17/EXMC_ALE Remap: TIMER3_CH0, USART2_RTS, ETH_MII_RXD3
PD13	60	I/O	5VT	Default: PD13 Alternate2: EXMC_A18 Remap: TIMER3_CH1
PD14	61	I/O	5VT	Default: PD14 Alternate2: EXMC_D0 Remap: TIMER3_CH2
PD15	62	I/O	5VT	Default: PD15 Alternate2: EXMC_D1 Remap: TIMER3_CH3, CTC_SYNC
PC6	63	I/O	5VT	Default: PC6 Alternate1: SHRTIMER_EXEV9, CMP5_OUT, USART5_TX Alternate2: I2S1_MCK, TIMER7_CH0 Remap: TIMER2_CH0
PC7	64	I/O	5VT	Default: PC7 Alternate1: SHRTIMER_FLT4, USART5_RX Alternate2: I2S2_MCK, TIMER7_CH1 Remap: TIMER2_CH1
PC8	65	I/O	5VT	Default: PC8 Alternate1: SHRTIMER_ST4CH0, USART5_CK Alternate2: TIMER7_CH2 Remap: TIMER2_CH2
PC9	66	I/O	5VT	Default: PC9 Alternate1: SHRTIMER_ST4CH1, I2C2_SDA Alternate2: TIMER7_CH3 Remap: TIMER2_CH3
PA8	67	I/O	5VT	Default: PA8 Alternate1: SHRTIMER_ST0CH0, I2C2_SCL Alternate2: USART0_CK, TIMER0_CH0, CK_OUT, USBHS_SOF, CTC_SYNC
PA9	68	I/O	5VT	Default: PA9 Alternate1: CAN2_RX, SHRTIMER_ST0CH1, I2C2_SMBA

Pin Name	Pins	Pin Type ⁽¹⁾	I/O Level ⁽²⁾	Functions description ⁽³⁾
				Alternate2: USART0_TX, TIMER0_CH1, USBHS_VBUS
PA10	69	I/O	5VT	Default: PA10 Alternate1: CAN2_TX, CMP5_OUT, SHRTIMER_ST1CH0 Alternate2: USART0_RX, TIMER0_CH2, USBHS_ID
PA11	70	I/O		Default: PA11 Alternate1: SHRTIMER_ST1CH1, USART5_TX Alternate2: USART0_CTS, CAN0_RX, TIMER0_CH3, USBHS_DM
PA12	71	I/O		Default: PA12 Alternate1: CMP1_OUT, SHRTIMER_FLT0, USART5_RX Alternate2: USART0_RTS, CAN0_TX, TIMER0_ETI, USBHS_DP
PA13	72	I/O	5VT	Default: JTMS, SWDIO Remap: PA13
NC	73			-
VSS_2	74	P		Default: VSS_2
VDD_2	75	P		Default: VDD_2
PA14	76	I/O	5VT	Default: JTCK, SWCLK Remap: PA14
PA15	77	I/O	5VT	Default: JTDI Alternate1: SHRTIMER_FLT1 Alternate2: SPI2_NSS, I2S2_WS Remap: TIMER1_CH0, TIMER1_ETI, PA15, SPI0_NSS
PC10	78	I/O	5VT	Default: PC10 Alternate1: I2C2_SCL Alternate2: UART3_TX Remap: USART2_TX, SPI2_SCK, I2S2_CK
PC11	79	I/O	5VT	Default: PC11 Alternate1: SHRTIMER_EXEV1, I2S2_ADD_SD Alternate2: UART3_RX Remap: USART2_RX, SPI2_MISO
PC12	80	I/O	5VT	Default: PC12 Alternate1: SHRTIMER_EXEV0 Alternate2: UART4_TX Remap: USART2_CK, SPI2_MOSI, I2S2_SD
PD0	81	I/O	5VT	Default: PD0 Alternate2: EXMC_D2 Remap: CAN0_RX
PD1	82	I/O	5VT	Default: PD1 Alternate2: EXMC_D3 Remap: CAN0_TX

Pin Name	Pins	Pin Type ⁽¹⁾	I/O Level ⁽²⁾	Functions description ⁽³⁾
PD2	83	I/O	5VT	Default: PD2 Alternate2: TIMER2_ETI, UART4_RX
PD3	84	I/O	5VT	Default: PD3 Alternate2: EXMC_CLK Remap: USART1_CTS
PD4	85	I/O	5VT	Default: PD4 Alternate1: SHRTIMER_FLT2 Alternate2: EXMC_NOE Remap: USART1_RTS
PD5	86	I/O	5VT	Default: PD5 Alternate1: SHRTIMER_EXEV2 Alternate2: EXMC_NWE Remap: USART1_TX
PD6	87	I/O	5VT	Default: PD6 Alternate2: EXMC_NWAIT Remap: USART1_RX
PD7	88	I/O	5VT	Default: PD7 Alternate2: EXMC_NE0, EXMC_NCE1 Remap: USART1_CK
PB3	89	I/O	5VT	Default: JTDO Alternate1: SHRTIMER_SCOUT, SHRTIMER_EXEV8 Alternate2: SPI2_SCK, I2S2_CK Remap: TIMER1_CH1, PB3, SPI0_SCK, TRACESWO
PB4	90	I/O	5VT	Default: NJTRST Alternate1: SHRTIMER_EXEV6, I2C2_SDA, I2S2_ADD_SD Alternate2: SPI2_MISO, I2C0_TXFRAME Remap: TIMER2_CH0, PB4, SPI0_MISO
PB5	91	I/O		Default: PB5 Alternate1: USBHS_ULPI_D7, SHRTIMER_EXEV5, I2C2_SCL Alternate2: I2C0_SMBA, SPI2_MOSI, I2S2_SD, ETH_MII_PPS_OUT, ETH_RMII_PPS_OUT, WKUP5 Remap: TIMER2_CH1, SPI0_MOSI, CAN1_RX
PB6	92	I/O	5VT	Default: PB6 Alternate1: SHRTIMER_SCIN, SHRTIMER_EXEV3 Alternate2: I2C0_SCL, TIMER3_CH0 Remap: USART0_TX, CAN1_TX, SPI0_IO2
PB7	93	I/O	5VT	Default: PB7 Alternate1: SHRTIMER_EXEV2 Alternate2: I2C0_SDA, TIMER3_CH1, EXMC_NADV Remap: USART0_RX, SPI0_IO3
BOOT0	94	I		Default: BOOT0

Pin Name	Pins	Pin Type ⁽¹⁾	I/O Level ⁽²⁾	Functions description ⁽³⁾
PB8	95	I/O	5VT	Default: PB8 Alternate1: SHRTIMER_EXEV7, I2C2_SDA Alternate2: TIMER3_CH2, TIMER9_CH0, ETH_MII_TXD3 Remap: I2C0_SCL, CAN0_RX
PB9	96	I/O	5VT	Default: PB9 Alternate1: CMP1_OUT, SHRTIMER_EXEV4 Alternate2: TIMER3_CH3, TIMER10_CH0 Remap: I2C0_SDA, CAN0_TX
PE0	97	I/O	5VT	Default: PE0 Alternate1: CAN2_RX, SHRTIMER_SCIN Alternate2: TIMER3_ETI, EXMC_NBL0
PE1	98	I/O	5VT	Default: PE1 Alternate1: CAN2_TX, SHRTIMER_SCOUT Alternate2: EXMC_NBL1
VSS_3	99	P		Default: VSS_3
VDD_3	100	P		Default: VDD_3

Notes:

(1) Type: I = input, O = output, P = power.

(2) I/O Level: 5VT = 5 V tolerant.

(3) Alternate1: The specified function can be mapped to the specific pin by configuring AFIO_PCFA ~ AFIO_PCFG registers.

Alternate2: These functions can be enabled with correct GPIO and function module mode configurations.

Remap: A group of the specified module functions can be mapped to the specified pins by configuring AFIO_PCF0 ~ AFIO_PCF1 registers.

3. Functional description

3.1. Arm® Cortex®-M33 core

The Cortex®-M33 processor is a 32-bit processor that possesses low interrupt latency and low-cost debug. The characteristics of integrated and advanced make the Cortex®-M33 processor suitable for market products that require microcontrollers with high performance and low power consumption.

32-bit Arm® Cortex®-M33 processor core

- Up to 180 MHz operation frequency
- Ultra-low power, energy-efficient operation
- Integrated Nested Vectored Interrupt Controller (NVIC)
- 24-bit SysTick timer

The Cortex®-M33 processor is based on the ARMv8 architecture and supports both Thumb and Thumb-2 instruction sets. Some system peripherals listed below are also provided by Cortex®-M33:

- Internal Bus Matrix connected with Code bus, System bus, and Private Peripheral Bus (PPB) and debug accesses
- Nested Vectored Interrupt Controller (NVIC)
- Breakpoint Unit (BPU)
- Data Watchpoint and Trace (DWT)
- Instrumentation Trace Macrocell (ITM)
- Serial Wire JTAG Debug Port (SWJ-DP)
- Trace Port Interface Unit (TPIU)
- Memory Protection Unit (MPU)
- Floating Point Unit (FPU)
- DSP Extension (DSP)

3.2. Embedded memory

- Up to 512 Kbytes of Flash memory
- Up to 128 Kbytes of SRAM

512 Kbytes of inner Flash and 128 Kbytes of inner SRAM at most is available for storing programs and data, and Flash is accessed (Read) at CPU clock speed with 0~4 waiting time.

[Table 2-2. GD32A508xx memory map](#) shows the memory map of the GD32A508xx series of devices, including code, SRAM, peripheral, and other pre-defined regions.

3.3. Clock, reset and supply management

- Internal 8 MHz factory-trimmed RC and external 4 to 32 MHz crystal oscillator
- Internal 48 MHz RC oscillator
- Internal 40 KHz RC calibrated oscillator and external 32.768 KHz crystal oscillator
- Integrated system clock PLL
- 1.71 to 3.63 V application supply and I/Os
- Supply Supervisor: POR (Power On Reset), PDR (Power Down Reset), and low voltage detector (LVD)

The Clock Control Unit (CCU) provides a range of oscillator and clock functions. These include speed internal RC oscillator and external crystal oscillator, high speed and low speed two types. Several prescalers allow the frequency configuration of the AHB and two APB domains. The maximum frequency of the AHB, APB2 and APB1 domains is 180 MHz/180 MHz/90 MHz. See [Figure 2-4. GD32A508xx clock tree](#) for details on the clock tree.

The Reset Control Unit (RCU) controls three kinds of reset: system reset resets the processor core and peripheral IP components. Power-on reset (POR) and power-down reset (PDR) are always active, and ensures proper operation starting from 1.56 V and down to 1.52V. The device remains in reset mode when V_{DD} is below a specified threshold. The embedded low voltage detector (LVD) monitors the power supply, compares it to the voltage threshold and generates an interrupt as a warning message for leading the MCU into security.

Power supply schemes:

- V_{DD} range: 1.71 to 3.63 V, external power supply for I/Os and the internal regulator. Provided externally through V_{DD} pins.
- V_{SSA} , V_{DDA} range: 1.71 to 3.63 V, external analog power supplies for ADC, reset blocks, RCs and PLL.
- V_{BAK} range: 1.71 to 3.63 V, power supply for RTC, external clock 32 kHz oscillator and backup registers (through power switch) when V_{DD} is not present.

3.4. Boot modes

At startup, boot pins are used to select one of three boot options:

- Boot from main Flash memory (default)
- Boot from system memory
- Boot from on-chip SRAM

In default condition, boot from main Flash memory is selected. The boot loader is located in the internal boot ROM memory (system memory). It is used to reprogram the Flash memory by using USART0 (PA9 and PA10) or USART1 (PD5 and PD6) or USB (PA9, PA11 and PA12).

3.5. Power saving modes

The MCU supports five kinds of power saving modes to achieve even lower power consumption. They are Sleep, Deep-sleep, Deep-sleep 1, Deep-sleep 2 and Standby mode. These operating modes reduce the power consumption and allow the application to achieve the best balance between the CPU operating time, speed and power consumption.

- **Sleep mode**

In sleep mode, only the clock of CPU core is off. All peripherals continue to operate and any interrupt/event can wake up the system.

- **Deep-sleep mode**

In Deep-sleep mode, all clocks in the V_{CORE} domain are off, and all of IRC8M, IRC48M, HXTAL and PLLs are disabled. The contents of SRAM and registers are preserved. Any interrupt or wakeup event from EXTI lines can wake up the system from the deep-sleep mode including the 16 external lines, the RTC alarm, LVD output, USB wakeup, Ethernet wakeup, I2C2 wakeup and USART5 wakeup. When exiting the deep-sleep mode, the IRC8M is selected as the system clock.

- **Deep-sleep 1 mode**

In Deep-sleep 1 mode, all clocks in the V_{CORE} domain are off, and all of IRC8M, IRC48M, HXTAL and PLLs are disabled. The power of COREOFF1 domain is cut off. The contents of registers in COREOFF1 domain are lost. Any interrupt or wakeup event from EXTI lines can wake up the system from the deep-sleep 1 mode including the 16 external lines, the RTC alarm, LVD output, USB wakeup, Ethernet wakeup, I2C2 wakeup and USART5 wakeup. Waking up from Deep-sleep 1 mode needs an additional delay to power on COREOFF1 domain. When exiting the deep-sleep 1 mode, the IRC8M is selected as the system clock.

- **Deep-sleep 2 mode**

In Deep-sleep 2 mode, all clocks in the V_{CORE} domain are off, and all of IRC8M, IRC48M, HXTAL and PLLs are disabled. The power of COREOFF0/COREOFF1 domain is cut off. The contents of SRAM except for the first 32K and registers in COREOFF0/COREOFF1 domain are lost. Any interrupt or wakeup event from EXTI lines can wake up the system from the deep-sleep mode including the 16 external lines, the RTC alarm, LVD output, USB wakeup, Ethernet wakeup, I2C2 wakeup and USART5 wakeup. Waking up from Deep-sleep 2 mode needs an additional delay to power on COREOFF1 domain. Waking up from Deep-sleep 2 mode needs an additional delay to power on COREOFF0/COREOFF1 domain. When exiting the deep-sleep 2 mode, the IRC8M is selected as the system clock.

- **Standby mode**

In Standby mode, the whole V_{CORE} domain is power off, the LDO is shut down, and all of IRC8M, IRC48M, HXTAL and PLL are disabled. There are four wakeup sources for the Standby mode, including the external reset from NRST pin, the RTC alarm, the FWDGT reset, and the rising edge on WKUP pins.

3.6. Analog to digital converter (ADC)

- 12-bit SAR ADC's conversion rate is up to 2.5 MSPS
- 12-bit, 10-bit, 8-bit or 6-bit configurable resolution
- Hardware oversampling ratio adjustable from 2 to 256x improves resolution to 16-bit
- Input voltage range: V_{REF-} to V_{REF+}
- Temperature sensor

Two 12-bit 2.5 MSPS multi-channel ADCs are integrated in the device. It has a total of 18 multiplexed channels: up to 16 external channels, 1 channel for internal temperature sensor (V_{SENSE}) and 1 channel for internal reference voltage (V_{REFINT}). The input voltage range is between V_{REF-} and V_{REF+} . An on-chip hardware oversampling scheme improves performance while off-loading the related computational burden from the CPU. The analog watchdog allows the application to detect whether the input voltage goes outside the user-defined higher or lower thresholds. A configurable channel management block can be used to perform conversions in single, continuous, scan or discontinuous mode to support more advanced use.

The ADC can be triggered from the events generated by the general level 0 timers (TIMERx), the advanced timers (TIMER0 and TIMER7) and SHRTIMER with internal connection. The temperature sensor can be used to generate a voltage that varies linearly with temperature. It is internally connected to the ADC_IN16 input channel which is used to convert the sensor output voltage in a digital value.

To ensure a high accuracy on ADC and DAC, the ADC/DAC independent external reference voltage should be connected to V_{REF+}/V_{REF-} pins. According to the different packages, V_{REF+} pin can be connected to V_{DDA} pin, or external reference voltage, V_{REF-} pin must be connected to V_{SSA} pin. The V_{REF+} pin is only available on no less than 100-pin packages, or else the V_{REF+} pin is not available and internally connected to V_{DDA} . The V_{REF-} pin is only available on no less than 100-pin packages, or else the V_{REF-} pin is not available and internally connected to V_{SSA} .

3.7. Digital to analog converter (DAC)

- Two 12-bit DACs with independent output channels
- 8-bit or 12-bit mode in conjunction with the DMA controller

The 12-bit buffered DAC is used to generate variable analog outputs. The DAC channels can be triggered by the timer, SHRTIMER or EXTI with DMA support. In dual DAC channel operation, conversions could be done independently or simultaneously. The maximum output value of the DAC is V_{REF+} .

3.8. DMA

- 7 channels for DMA0 controller and 5 channels for DMA1 controller

- Peripherals supported: Timers, SHRTIMER, ADCs, DACs, SPIs, I2Cs, USARTs and I2S

The flexible general-purpose DMA controllers provide a hardware method of transferring data between peripherals and/or memory without intervention from the CPU, thereby freeing up bandwidth for other system functions. Three types of access method are supported: peripheral to memory, memory to peripheral, memory to memory.

Each channel is connected to fixed hardware DMA requests. The priorities of DMA channel requests are determined by software configuration and hardware channel number. Transfer size of source and destination are independent and configurable.

3.9. General-purpose inputs/outputs (GPIOs)

- Up to 112 fast GPIOs, all mappable on 16 external interrupt lines
- Analog input/output configurable
- Alternate function input/output configurable

There are up to 112 general purpose I/O pins (GPIO) in GD32A508xx, named PA0 ~ PA15, PB0 ~ PB15, PC0 ~ PC15, PD0 ~ PD15, PE0 ~ PE15, PF0 ~ PF15 and PG0 ~ PG15 to implement logic input/output functions. Each of the GPIO ports has related control and configuration registers to satisfy the requirements of specific applications. The external interrupts on the GPIO pins of the device have related control and configuration registers in the Interrupt/event controller (EXTI). The GPIO ports are pin-shared with other alternative functions (AFs) to obtain maximum flexibility on the package pins. Each of the GPIO pins can be configured by software as output (push-pull or open-drain), input, peripheral alternate function or analog mode. Most of the GPIO pins are shared with digital or analog alternate functions.

3.10. Timers and PWM generation

- Two 16-bit advanced timer (TIMER0, TIMER7), one 32-bit general timer (TIMER1), up to nine 16-bit general timers (TIMER2 ~ TIMER4, TIMER8 ~ TIMER13), and two 16-bit basic timer (TIMER5, TIMER6)
- Up to 4 independent channels of PWM, output compare or input capture for each general timer and external trigger input
- 16-bit, motor control PWM advanced timer with programmable dead-time generation for output match
- Encoder interface controller with two inputs using quadrature decoder
- 24-bit SysTick timer down counter
- 2 watchdog timers (free watchdog timer and window watchdog timer)

The advanced timer (TIMER0, TIMER7) can be used as a three-phase PWM multiplexed on 6 channels. It has complementary PWM outputs with programmable dead-time generation. It can also be used as a complete general timer. The 4 independent channels can be used for input capture, output compare, PWM generation (edge- or center- aligned counting modes)

and single pulse mode output. If configured as a general 16-bit timer, it has the same functions as the TIMEx timer. It can be synchronized with external signals or to interconnect with other general timers together which have the same architecture and features.

The general timer can be used for a variety of purposes including general time, input signal pulse width measurement or output waveform generation such as a single pulse generation or PWM output, up to 4 independent channels for input capture/output compare. TIMER1 is based on a 32-bit auto-reload up/down counter and a 16-bit prescaler. TIMER2 ~ TIMER4 is based on a 16-bit auto-reload up/down counter and a 16-bit prescaler. TIMER8 ~ TIMER13 is based on a 16-bit auto-reload up counter and a 16-bit prescaler. The general timer also supports an encoder interface with two inputs using quadrature decoder.

The basic timer, known as TIMER5 &TIMER6, are mainly used for DAC trigger generation. They can also be used as a simple 16-bit time base.

The GD32A508xx have two watchdog peripherals, free watchdog timer and window watchdog timer. They offer a combination of high safety level, flexibility of use and timing accuracy.

The free watchdog timer includes a 12-bit down-counting counter and an 8-stage prescaler. It is clocked from an independent 40 KHz internal RC and as it operates independently of the main clock, it can operate in deep-sleep, deep-sleep 1, deep-sleep 2 and standby modes. It can be used either as a watchdog to reset the device when a problem occurs, or as a free-running timer for application timeout management.

The window watchdog is based on a 7-bit down counter that can be set as free-running. It can be used as a watchdog to reset the device when a problem occurs. It is clocked from the main clock. It has an early wakeup interrupt capability and the counter can be frozen in debug mode.

The SysTick timer is dedicated for OS, but could also be used as a standard down counter. The features are shown below:

- A 24-bit down counter
- Auto reload capability
- Maskable system interrupt generation when the counter reaches 0
- Programmable clock source

3.11. Real time clock (RTC)

- 32-bit programmable counter with a programmable 20-bit prescaler
- Alarm function
- Interrupt and wakeup event

The real time clock is an independent timer which provides a set of continuously running counters in backup registers to provide a real calendar function, and provides an alarm interrupt or an expected interrupt. The RTC features a 32-bit programmable counter for long-term measurement using the compare register to generate an alarm. A 20-bit prescaler is used for the time base clock and is by default configured to generate a time base of 1 second

from a clock at 32.768 KHz from external crystal oscillator.

3.12. Inter-integrated circuit (I2C)

I2C0 and I2C1:

- Support both master and slave mode with a frequency up to 1 MHz (Fast mode plus)
- Provide arbitration function, optional PEC (packet error checking) generation and checking
- Supports 7-bit and 10-bit addressing mode and general call addressing mode
- SMBus 2.0 and PMBus compatible
- Supports SAM_V mode

I2C2:

- Support both master and slave mode with a frequency up to 1 MHz (Fast mode plus)
- Provide arbitration function, optional PEC (packet error checking) generation and checking
- Supports 7-bit and 10-bit addressing mode and general call addressing mode
- SMBus 3.0 and PMBus 1.3 compatible
- Wakeup from Deep-sleep mode on address match

The I2C interface is an internal circuit allowing communication with an external I2C interface which is an industry standard two line serial interface used for connection to external hardware. These two serial lines are known as a serial data line (SDA) and a serial clock line (SCL). The I2C module provides different data transfer rates: up to 100 KHz in standard mode, up to 400 KHz in the fast mode and up to 1 MHz in the fast mode plus. The I2C module also has an arbitration detect function to prevent the situation where more than one master attempts to transmit data to the I2C bus at the same time. A CRC-8 calculator is also provided in I2C interface to perform packet error checking for I2C data.

3.13. Serial peripheral interface (SPI)

- Up to three SPI interfaces
- Support both master and slave mode
- Hardware CRC calculation and transmit automatic CRC error checking
- Quad-SPI configuration available in master mode (only in SPI0)

The SPI interface uses 4 pins, among which are the serial data input and output lines (MISO & MOSI), the clock line (SCK) and the slave select line (NSS). All SPIs can be served by the DMA controller. The SPI interface may be used for a variety of purposes, including simplex synchronous transfers on two lines with a possible bidirectional data line or reliable communication using CRC checking. Quad-SPI master mode is also supported in SPI0.

3.14. Universal synchronous asynchronous receiver transmitter (USART)

USART0~2, UART3~4:

- Maximum speed up to 22.5 MBits/s for USART0
- Maximum speed up to 11.25 MBits/s for USART1~2, UART3~4
- Supports both asynchronous and clocked synchronous serial communication modes
- IrDA SIR encoder and decoder support
- LIN break generation and detection
- ISO 7816-3 compliant smart card interface

USART5:

- Maximum speed up to 22.5 MBits/s
- Supports both asynchronous and clocked synchronous serial communication modes
- IrDA SIR encoder and decoder support
- LIN break generation and detection
- ISO 7816-3 compliant smart card interface
- Dual clock domain
- Wake up from Deep-sleep mode

The USART (USART0, USART1, USART2, USART5) are used to translate data between parallel and serial interfaces, provides a flexible full duplex data exchange using synchronous or asynchronous transfer. It is also commonly used for RS-232 standard communication. The USART includes a programmable baud rate generator which is capable of dividing the system clock to produce a dedicated clock for the USART transmitter and receiver. The USART also supports DMA function for high speed data communication.

3.15. Inter-IC sound (I2S)

- Two I2S bus Interfaces with sampling frequency from 8 KHz to 192 KHz
- Support either master or slave mode

The Inter-IC sound (I2S) bus provides a standard communication interface for digital audio applications by 4-wire serial lines. GD32A508xx contain an I2S-bus interface that can be operated with 16/32 bit resolution in master or slave mode, pin multiplexed with SPI1 and SPI2. The audio sampling frequency from 8 KHz to 192 KHz is supported.

3.16. Universal serial bus High-Speed interface (USBHS)

- One USB device/host/OTG high-speed interface with frequency up to 480Mbit/s.
- Include a USB PHY with OTG protocol supported

USB High-Speed (USBHS) controller provides a USB-connection solution for portable devices. USBHS supports both host and device modes, as well as OTG mode with HNP (Host

Negotiation Protocol) and SRP (Session Request Protocol). USBHS contains an embedded USB PHY internal which can be configured as High-Speed or Full-Speed. USBHS supports all the four types of transfer (control, bulk, Interrupt and isochronous) defined in USB 2.0 protocol. There is also a DMA engine operating as an AHB bus master in USBHS to speed up the data transfer between USBHS and system. For Full-Speed operation, battery charging detection (BCD), attach detection protocol (ADP), and link power management (LPM) are also supported.

3.17. Controller area network (CAN)

- Three CAN interfaces supports the CAN protocols version 2.0A and B, ISO11891-1:2015 and BOSCH CAN FD specification with baud rates up to 1 Mbit/s when classical frames and 6 Mbit/s when FD frames.
- Supports CAN FD Frame with up to 64 data bytes (ISO11898-1 and Bosch CAN FD specification V1.0).

Controller area network (CAN) is a method for enabling serial communication in field bus. The CAN protocol has been used extensively in industrial automation and automotive applications. It can receive and transmit standard frames with 11-bit identifiers as well as extended frames with 29-bit identifiers. Each CAN has three mailboxes for transmission and two FIFOs of three messages depth for reception. The CAN0 and CAN1 provides 28 scalable/configurable identifier filter banks for selecting the incoming messages needed and discarding the others. The CAN2 independently provides 14 scalable/configurable identifier filter banks in GD32A508xx.

3.18. Ethernet (ENET)

- IEEE 802.3 compliant media access controller (MAC) for Ethernet LAN
- 10/100 Mbit/s rates with dedicated DMA controller and SRAM
- Support hardware precision time protocol (PTP) with conformity to IEEE 1588

The Ethernet media access controller (MAC) conforms to IEEE 802.3 specifications and fully supports IEEE 1588 standards. The embedded MAC provides the interface to the required external network physical interface (PHY) for LAN bus connection via an internal media independent interface (MII) or a reduced media independent interface (RMII). The number of MII signals provided up to 16 with 25 MHz output and RMII up to 7 with 50 MHz output. The function of 32-bit CRC checking is also available.

3.19. External memory controller (EXMC)

- Supported external memory: SRAM, PSRAM, ROM and NOR-Flash, NAND Flash and PC card
- Up to 16-bit data bus

- Support to interface with Motorola 6800 and Intel 8080 type LCD directly

External memory controller (EXMC) is an abbreviation of external memory controller. It is divided in to several sub-banks for external device support, each sub-bank has its own chip selection signal but at one time, only one bank can be accessed. The EXMC support code execution from external memory except NAND Flash and PC card. The EXMC also can be configured to interface with the most common LCD module of Motorola 6800 and Intel 8080 series and reduce the system cost and complexity.

3.20. Comparators (CMP)

- Three fast rail-to-rail low-power comparators with software configurable
- Programmable reference voltage (internal or external I/O)

Three Comparators (CMP) are implemented within the devices. They can work either standalone (all terminal are available on I/Os) or together with the timers. The internal voltage reference is also connected to ADC_IN17 input channel of the ADC.

3.21. Trigonometric Math Unit (TMU)

- Operation data support IEEE 32-Bit Single Precision Floating-Point Format

The Trigonometric Math Unit (TMU) is a fully configurable block that execute common trigonometric and arithmetic operations. The TMU calculation unit can be used to calculate total 9 kinds of operations. For mode 0 and 1, operation finishes in 4 clock cycles. For others mode, 7 clock cycles is needed.

3.22. Super High-Resolution Timer (SHRTIMER)

- High- precision timing units: Master_TIMER, Slave_TIMERx (x=0..4).
- Synchronization outputs: synchronize external resources as master.
- Synchronization inputs: be synchronized as a slaver.
- Bunch mode controller to handle light-load operation.
- 6 DMA request: Master_TIMER requests, Slave_TIMERx (x=0..4) requests.

SHRTIMER has a high-precision counting clock and can be used for high-precision timing. It can generate 10 high precision and flexible digital signals to control motor or be used for power management applications. It has multiple internal signals connected to the ADC and DAC. It can be used for control and monitoring purposes. It can handle various fault input for safe purposes.

3.23. Serial/Quad Parallel Interface (SQPI)

- SQPI controller support configuring output clock frequency which is divided by HCLK.

- SQPI controller support no address phase and data phase operation which is named special command by the controller.
- SQPI controller support 256MB external memory space.
Logic memory address range: 0xB000_0000 - 0xBFFF_FFFF.
- SQPI controller support 6 types mode for different combination of command, address, waitcycle, and data phase.

Serial/Quad Parallel Interface (SQPI) is a controller for external serial/dual/quad parallel interface memory peripheral. For example: SQPI-PSRAM and SQPI-FLASH. With this controller, users can use external SQPI interface memory as SRAM simply.

3.24. Debug mode

- Serial wire JTAG debug port (SWJ-DP)

The Arm® SWJ-DP Interface is embedded and is a combined JTAG and serial wire debug port that enables either a serial wire debug or a JTAG probe to be connected to the target.

3.25. Package and operation temperature

- LQFP144 (GD32A508Zx) and LQFP100 (GD32A508Vx).
- Operation temperature range: -40°C to +105°C (Automotive level)

4. Electrical characteristics

4.1. Absolute maximum ratings

The maximum ratings are the limits to which the device can be subjected without permanently damaging the device. Note that the device is not guaranteed to operate properly over the maximum ratings. Exposure to the absolute maximum rating conditions for extended periods may affect device reliability.

Table 4-1. Absolute maximum ratings ⁽¹⁾⁽⁴⁾

Symbol	Parameter	Min	Max	Unit
V _{DD}	External voltage range ⁽²⁾	V _{SS} - 0.3	V _{SS} + 3.63	V
V _{DDA}	External analog supply voltage	V _{SSA} - 0.3	V _{SSA} + 3.63	V
V _{BAT}	External battery supply voltage	V _{SS} - 0.3	V _{SS} + 3.63	V
V _{IN}	Input voltage on 5V tolerant pin ⁽³⁾	V _{SS} - 0.3	V _{DD} + 3.63	V
	Input voltage on other I/O	V _{SS} - 0.3	3.63	V
ΔV _{DDx}	Variations between different VDD power pins	—	50	mV
V _{SSx} - V _{SS}	Variations between different ground pins	—	50	mV
I _{IO}	Maximum current for GPIO pins	—	±25	mA
I _{IOS}	Maximum current for multiple IO ⁽⁵⁾	—	100	mA
T _A	Operating temperature range	-40	+105	°C
P _D	Power dissipation at T _A = 105°C of LQFP144	—	410	mW
	Power dissipation at T _A = 105°C of LQFP100	—	407	
T _{STG}	Storage temperature range	-65	+150	°C
T _J	Maximum junction temperature	—	125	°C

(1) Guaranteed by design, not tested in production.

(2) All main power and ground pins should be connected to an external power source within the allowable range.

(3) V_{IN} maximum value cannot exceed 5.5 V.

(4) It is recommended that V_{DD} and V_{DDA} are powered by the same source. The maximum difference between V_{DD} and V_{DDA} does not exceed 300 mV during power-up and operation.

(5) T_J = 110°C.

4.2. Operating conditions characteristics

Table 4-2. DC operating conditions

Symbol	Parameter	Conditions	Min ⁽¹⁾	Typ	Max ⁽¹⁾	Unit
V _{DD}	Supply voltage	—	1.71	3.3	3.63	V
V _{DDA}	Analog supply voltage, f _{ADCMAX} = 35 MHz	—	2.4	3.3	3.63	V
	Analog supply voltage, f _{ADCMAX} = 14 MHz		1.71	—	3.63	
V _{BAT}	Battery supply voltage	—	1.71 ⁽²⁾	—	3.63	V
V _{CORE}	Core logic supply voltage powered by internal voltage regulator	—	—	1.1	—	V

(1) Based on characterization, not tested in production.

- (2) In the application which V_{BAT} supply the backup domains, if the V_{BAT} voltage drops below the minimum value, when V_{DD} is powered on again, it is necessary to refresh the registers of backup domains and enable LXTAL again.

Figure 4-1. Recommended power supply decoupling capacitors ⁽¹⁾⁽²⁾

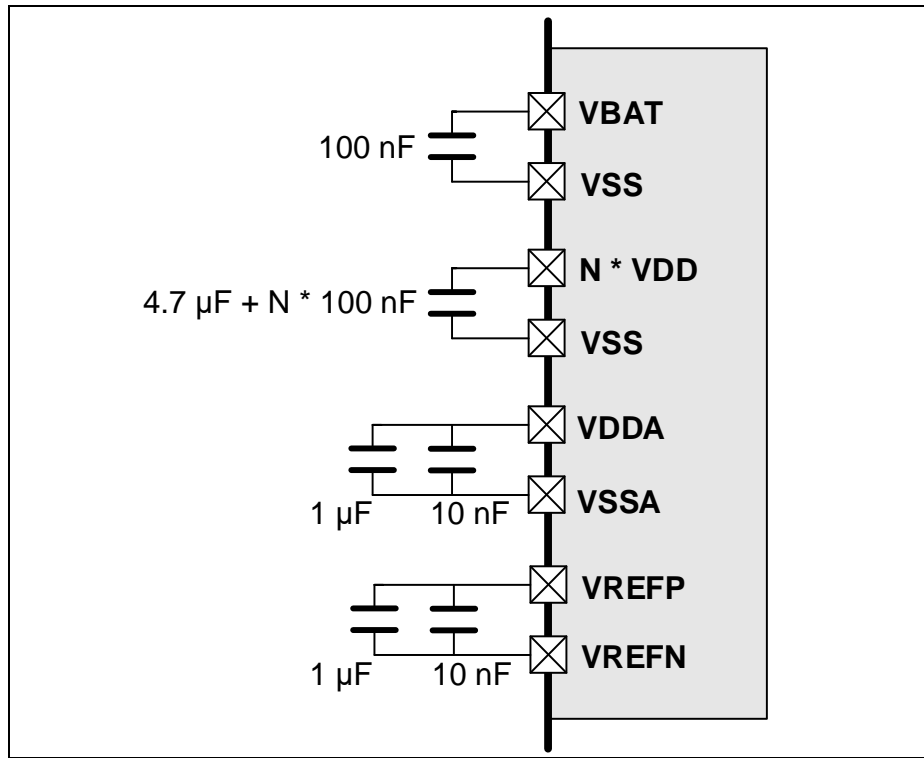

- (1) The VREFP and VREFN pins are only available on no less than 100-pin packages, or else the VREFP and VREFN pins are not available and internally connected to VDDA and VSSA pins.
 (2) All decoupling capacitors need to be as close as possible to the pins on the PCB board.

Table 4-3. Clock frequency ⁽¹⁾

Symbol	Parameter	Conditions	Min	Max	Unit
f_{HCLK}	AHB clock frequency	—	—	180	MHz
f_{APB1}	APB1 clock frequency	—	—	90	MHz
f_{APB2}	APB2 clock frequency	—	—	180	MHz

- (1) Guaranteed by design, not tested in production.

Table 4-4. Operating conditions at Power up/ Power down ⁽¹⁾

Symbol	Parameter	Conditions	Min	Max	Unit
t_{VDD}	V_{DD} rise time rate	—	0	∞	$\mu\text{s}/\text{V}$
	V_{DD} fall time rate		50	∞	

- (1) Guaranteed by design, not tested in production.

Table 4-5. Start-up timings of Operating conditions ⁽¹⁾⁽²⁾⁽³⁾

Symbol	Parameter	Conditions	Typ	Unit
$t_{start-up}$	Start-up time	Clock source from HXTAL	608	μs
		Clock source from IRC8M	74	

- (1) Based on characterization, not tested in production.
 (2) After power-up, the start-up time is the time between the rising edge of NRST high and the first I/O instruction conversion in SystemInit function.
 (3) PLL is off.

Table 4-6. Power saving mode wakeup timings characteristics ⁽¹⁾⁽²⁾

Symbol	Parameter	Typ	Unit
t_{Sleep}	Wakeup from Sleep mode	1.7	μs
$t_{\text{Deep-sleep}}$	Wakeup from Deep-sleep mode (LDO On)	3.1	
	Wakeup from Deep-sleep mode (LDO in low power mode)	3.1	
	Wakeup from Deep-sleep mode1 (LDO in low power and low driver mode)	4.3	
	Wakeup from Deep-sleep mode2 (LDO in low power and low driver mode)	11.7	
t_{Standby}	Wakeup from Standby mode	77.2	

(1) Based on characterization, not tested in production.

(2) The wakeup time is measured from the wakeup event to the point at which the application code reads the first instruction under the below conditions: $V_{\text{DD}} = V_{\text{DDA}} = 3.3 \text{ V}$, IRC8M = System clock = 8 MHz.

4.3. Power consumption

The power measurements specified in the tables represent that code with data executing from on-chip Flash with the following specifications.

Table 4-7. Power consumption characteristics ⁽²⁾⁽³⁾⁽⁴⁾⁽⁵⁾⁽⁶⁾

Symbol	Parameter	Conditions	Min	Typ ⁽¹⁾	Max	Unit
$I_{\text{DD}}+I_{\text{DDA}}$	Supply current (Run mode)	$V_{\text{DD}} = V_{\text{DDA}} = 3.3 \text{ V}$, HXTAL = 25 MHz, System clock = 180 MHz, All peripherals enabled	—	59.8	—	mA
		$V_{\text{DD}} = V_{\text{DDA}} = 3.3 \text{ V}$, HXTAL = 25 MHz, System clock = 180 MHz, All peripherals disabled	—	26.1	—	mA
		$V_{\text{DD}} = V_{\text{DDA}} = 3.3 \text{ V}$, HXTAL = 25 MHz, System clock = 160 MHz, All peripherals enabled	—	53.6	—	mA
		$V_{\text{DD}} = V_{\text{DDA}} = 3.3 \text{ V}$, HXTAL = 25 MHz, System clock = 160 MHz, All peripherals disabled	—	23.5	—	mA
		$V_{\text{DD}} = V_{\text{DDA}} = 3.3 \text{ V}$, HXTAL = 25 MHz, System clock = 120 MHz, All peripherals enabled	—	41	—	mA
		$V_{\text{DD}} = V_{\text{DDA}} = 3.3 \text{ V}$, HXTAL = 25 MHz, System clock = 120 MHz, All peripherals disabled	—	18.2	—	mA
		$V_{\text{DD}} = V_{\text{DDA}} = 3.3 \text{ V}$, HXTAL = 25 MHz, System clock = 108 MHz, All peripherals enabled	—	37.2	—	mA
		$V_{\text{DD}} = V_{\text{DDA}} = 3.3 \text{ V}$, HXTAL = 25 MHz, System clock = 108 MHz, All peripherals disabled	—	16.6	—	mA

Symbol	Parameter	Conditions	Min	Typ ⁽¹⁾	Max	Unit
		disabled				
		V _{DD} = V _{DDA} = 3.3 V, HXTAL = 25 MHz, System clock = 96 MHz, All peripherals enabled	—	33.4	—	mA
		V _{DD} = V _{DDA} = 3.3 V, HXTAL = 25 MHz, System clock = 96 MHz, All peripherals disabled	—	15	—	mA
		V _{DD} = V _{DDA} = 3.3 V, HXTAL = 25 MHz, System clock = 72 MHz, All peripherals enabled	—	25.7	—	mA
		V _{DD} = V _{DDA} = 3.3 V, HXTAL = 25 MHz, System clock = 72 MHz, All peripherals disabled	—	11.8	—	mA
		V _{DD} = V _{DDA} = 3.3 V, HXTAL = 25 MHz, System clock = 48 MHz, All peripherals enabled	—	18	—	mA
		V _{DD} = V _{DDA} = 3.3 V, HXTAL = 25 MHz, System clock = 48 MHz, All peripherals disabled	—	7.96	—	mA
		V _{DD} = V _{DDA} = 3.3 V, HXTAL = 25 MHz, System clock = 36 MHz, All peripherals enabled	—	14	—	mA
		V _{DD} = V _{DDA} = 3.3 V, HXTAL = 25 MHz, System clock = 36 MHz, All peripherals disabled	—	6.49	—	mA
		V _{DD} = V _{DDA} = 3.3 V, HXTAL = 25 MHz, System clock = 24 MHz, All peripherals enabled	—	9.73	—	mA
		V _{DD} = V _{DDA} = 3.3 V, HXTAL = 25 MHz, System clock = 24 MHz, All peripherals disabled	—	4.83	—	mA
		V _{DD} = V _{DDA} = 3.3 V, HXTAL = 25 MHz, System clock = 16 MHz, All peripherals enabled	—	7.2	—	mA
		V _{DD} = V _{DDA} = 3.3 V, HXTAL = 25 MHz, System clock = 16 MHz, All peripherals disabled	—	3.9	—	mA
		V _{DD} = V _{DDA} = 3.3 V, HXTAL = 25 MHz, System clock = 8 MHz, All peripherals enabled	—	4.62	—	mA
		V _{DD} = V _{DDA} = 3.3 V, HXTAL = 25 MHz, System clock = 8 MHz, All peripherals disabled	—	2.9	—	mA

Symbol	Parameter	Conditions	Min	Typ ⁽¹⁾	Max	Unit
		V _{DD} = V _{DDA} = 3.3 V, IRC = 8 MHz, System clock = 8 MHz, All peripherals enabled	—	3.1	—	mA
		V _{DD} = V _{DDA} = 3.3 V, IRC = 8 MHz, System clock = 8 MHz, All peripherals disabled	—	1.7	—	mA
	Supply current (Sleep mode)	V _{DD} = V _{DDA} = 3.3 V, HXTAL = 25 MHz, System Clock = 180 MHz, CPU clock off, All peripherals enabled	—	47.8	—	mA
		V _{DD} = V _{DDA} = 3.3 V, HXTAL = 25 MHz, System Clock = 180 MHz, CPU clock off, All peripherals disabled	—	9.5	—	mA
		V _{DD} = V _{DDA} = 3.3 V, HXTAL = 25 MHz, System Clock = 160 MHz, CPU clock off, All peripherals enabled	—	42.8	—	mA
		V _{DD} = V _{DDA} = 3.3 V, HXTAL = 25 MHz, System Clock = 160 MHz, CPU clock off, All peripherals disabled	—	8.7	—	mA
		V _{DD} = V _{DDA} = 3.3 V, HXTAL = 25 MHz, System Clock = 120 MHz, CPU clock off, All peripherals enabled	—	32.8	—	mA
		V _{DD} = V _{DDA} = 3.3 V, HXTAL = 25 MHz, System Clock = 120 MHz, CPU clock off, All peripherals disabled	—	7.07	—	mA
		V _{DD} = V _{DDA} = 3.3 V, HXTAL = 25 MHz, System Clock = 108 MHz, CPU clock off, All peripherals enabled	—	29.8	—	mA
		V _{DD} = V _{DDA} = 3.3 V, HXTAL = 25 MHz, System Clock = 108 MHz, CPU clock off, All peripherals disabled	—	6.57	—	mA
		V _{DD} = V _{DDA} = 3.3 V, HXTAL = 25 MHz, System Clock = 96 MHz, CPU clock off, All peripherals enabled	—	26.7	—	mA
		V _{DD} = V _{DDA} = 3.3 V, HXTAL = 25 MHz, System Clock = 96 MHz, CPU clock off, All peripherals disabled	—	6.1	—	mA
		V _{DD} = V _{DDA} = 3.3 V, HXTAL = 25 MHz, System Clock = 72 MHz, CPU clock off, All peripherals enabled	—	20.7	—	mA
		V _{DD} = V _{DDA} = 3.3 V, HXTAL = 25 MHz, System Clock = 72 MHz, CPU clock off, All peripherals disabled	—	5.1	—	mA
		V _{DD} = V _{DDA} = 3.3 V, HXTAL = 25 MHz, System Clock = 48 MHz, CPU clock off, All peripherals enabled	—	14.5	—	mA

Symbol	Parameter	Conditions	Min	Typ ⁽¹⁾	Max	Unit
		V _{DD} = V _{DDA} = 3.3 V, HXTAL = 25 MHz, System Clock = 48 MHz, CPU clock off, All peripherals disabled	—	4.1	—	mA
		V _{DD} = V _{DDA} = 3.3 V, HXTAL = 25 MHz, System Clock = 36 MHz, CPU clock off, All peripherals enabled	—	11.4	—	mA
		V _{DD} = V _{DDA} = 3.3 V, HXTAL = 25 MHz, System Clock = 36 MHz, CPU clock off, All peripherals disabled	—	3.6	—	mA
		V _{DD} = V _{DDA} = 3.3 V, HXTAL = 25 MHz, System Clock = 24 MHz, CPU clock off, All peripherals enabled	—	8.3	—	mA
		V _{DD} = V _{DDA} = 3.3 V, HXTAL = 25 MHz, System Clock = 24 MHz, CPU clock off, All peripherals disabled	—	3.1	—	mA
		V _{DD} = V _{DDA} = 3.3 V, HXTAL = 25 MHz, System Clock = 16 MHz, CPU clock off, All peripherals enabled	—	6.2	—	mA
		V _{DD} = V _{DDA} = 3.3 V, HXTAL = 25 MHz, System Clock = 16 MHz, CPU clock off, All peripherals disabled	—	2.7	—	mA
		V _{DD} = V _{DDA} = 3.3 V, HXTAL = 25 MHz, System Clock = 8 MHz, CPU clock off, All peripherals enabled	—	4.2	—	mA
		V _{DD} = V _{DDA} = 3.3 V, HXTAL = 25 MHz, System Clock = 8 MHz, CPU clock off, All peripherals disabled	—	2.4	—	mA
		V _{DD} = V _{DDA} = 3.3 V, IRC = 8 MHz, System Clock = 8 MHz, CPU clock off, All peripherals enabled	—	2.8	—	mA
		V _{DD} = V _{DDA} = 3.3 V, IRC = 8 MHz, System Clock = 8 MHz, CPU clock off, All peripherals disabled	—	1.1	—	mA
	Supply current (Deep-Sleep mode)	V _{DD} = V _{DDA} = 3.3 V, LDO in normal power and normal driver mode, IRC40K off, RTC off	—	461.33	—	μA
		V _{DD} = V _{DDA} = 3.3 V, LDO in low power and normal driver mode, IRC40K off, RTC off	—	413.00	—	μA
		V _{DD} = V _{DDA} = 3.3 V, LDO in normal power and low driver mode, IRC40K off, RTC off	—	258.00	—	μA
		V _{DD} = V _{DDA} = 3.3 V, LDO in low power and low driver mode, IRC40K off, RTC off, All GPIOs analog mode	—	210.67	—	μA

Symbol	Parameter	Conditions	Min	Typ ⁽¹⁾	Max	Unit
	Supply current (Deep-Sleep 1 mode)	$V_{DD} = V_{DDA} = 3.3\text{ V}$, LDO in low power and low driver mode, IRC40K off, RTC off	—	163.33	—	μA
	Supply current (Deep-Sleep 2 mode)	$V_{DD} = V_{DDA} = 3.3\text{ V}$, LDO in low power and low driver mode, IRC40K off, RTC off	—	68.00	—	μA
	Supply current (Standby mode)	$V_{DD} = V_{DDA} = 3.3\text{ V}$, LXTAL off, IRC40K on, RTC on	—	3.79	—	μA
		$V_{DD} = V_{DDA} = 3.3\text{ V}$, LXTAL off, IRC40K on, RTC off	—	3.58	—	μA
		$V_{DD} = V_{DDA} = 3.3\text{ V}$, LXTAL off, IRC40K off, RTC off	—	3.08	—	μA
I_{BAT}	Battery supply current (Backup mode)	V_{DD} off, V_{DDA} off, $V_{BAT} = 3.63\text{ V}$, LXTAL on with external crystal, RTC on, LXTAL High driving	—	1.95	—	μA
		V_{DD} off, V_{DDA} off, $V_{BAT} = 3.3\text{ V}$, LXTAL on with external crystal, RTC on, LXTAL High driving	—	1.82	—	μA
		V_{DD} off, V_{DDA} off, $V_{BAT} = 2.5\text{ V}$, LXTAL on with external crystal, RTC on, LXTAL High driving	—	1.67	—	μA
		V_{DD} off, V_{DDA} off, $V_{BAT} = 1.71\text{ V}$, LXTAL on with external crystal, RTC on, LXTAL High driving	—	1.59	—	μA
		V_{DD} off, V_{DDA} off, $V_{BAT} = 3.63\text{ V}$, LXTAL on with external crystal, RTC on, LXTAL Medium High driving	—	1.53	—	μA
		V_{DD} off, V_{DDA} off, $V_{BAT} = 3.3\text{ V}$, LXTAL on with external crystal, RTC on, LXTAL Medium High driving	—	1.40	—	μA
		V_{DD} off, V_{DDA} off, $V_{BAT} = 2.5\text{ V}$, LXTAL on with external crystal, RTC on, LXTAL Medium High driving	—	1.25	—	μA
		V_{DD} off, V_{DDA} off, $V_{BAT} = 1.71\text{ V}$, LXTAL on with external crystal, RTC on, LXTAL Medium High driving	—	1.18	—	μA
		V_{DD} off, V_{DDA} off, $V_{BAT} = 3.63\text{ V}$, LXTAL on with external crystal, RTC on, LXTAL Medium Low driving	—	1.12	—	μA
		V_{DD} off, V_{DDA} off, $V_{BAT} = 3.3\text{ V}$, LXTAL on with external crystal, RTC on, LXTAL	—	0.99	—	μA

Symbol	Parameter	Conditions	Min	Typ ⁽¹⁾	Max	Unit
		Medium Low driving				
		V _{DD} off, V _{DDA} off, V _{BAT} = 2.5 V, LXTAL on with external crystal, RTC on, LXTAL Medium Low driving	—	0.84	—	μA
		V _{DD} off, V _{DDA} off, V _{BAT} = 1.71 V, LXTAL on with external crystal, RTC on, LXTAL Medium Low driving	—	0.77	—	μA
		V _{DD} off, V _{DDA} off, V _{BAT} = 3.63 V, LXTAL on with external crystal, RTC on, LXTAL Low driving	—	1.00	—	μA
		V _{DD} off, V _{DDA} off, V _{BAT} = 3.3 V, LXTAL on with external crystal, RTC on, LXTAL Low driving	—	0.87	—	μA
		V _{DD} off, V _{DDA} off, V _{BAT} = 2.5 V, LXTAL on with external crystal, RTC on, LXTAL Low driving	—	0.72	—	μA
		V _{DD} off, V _{DDA} off, V _{BAT} = 1.71 V, LXTAL on with external crystal, RTC on, LXTAL Low driving	—	0.63	—	μA

- (1) Based on characterization, not tested in production.
- (2) Unless otherwise specified, all values given for T_A = 25 °C and test result is mean value.
- (3) When System Clock is less than 4 MHz, an external source is used, and the HXTAL bypass function is needed, no PLL.
- (4) When System Clock is greater than 8 MHz, a crystal 25 MHz is used, and the HXTAL bypass function is closed, using PLL.
- (5) When analog peripheral blocks such as ADCs, DACs, HXTAL, LXTAL, IRC8M, or IRC40K are ON, an additional power consumption should be considered.
- (6) All GPIOs are configured as analog mode except standby mode.

Figure 4-2. Typical supply current consumption in Run mode

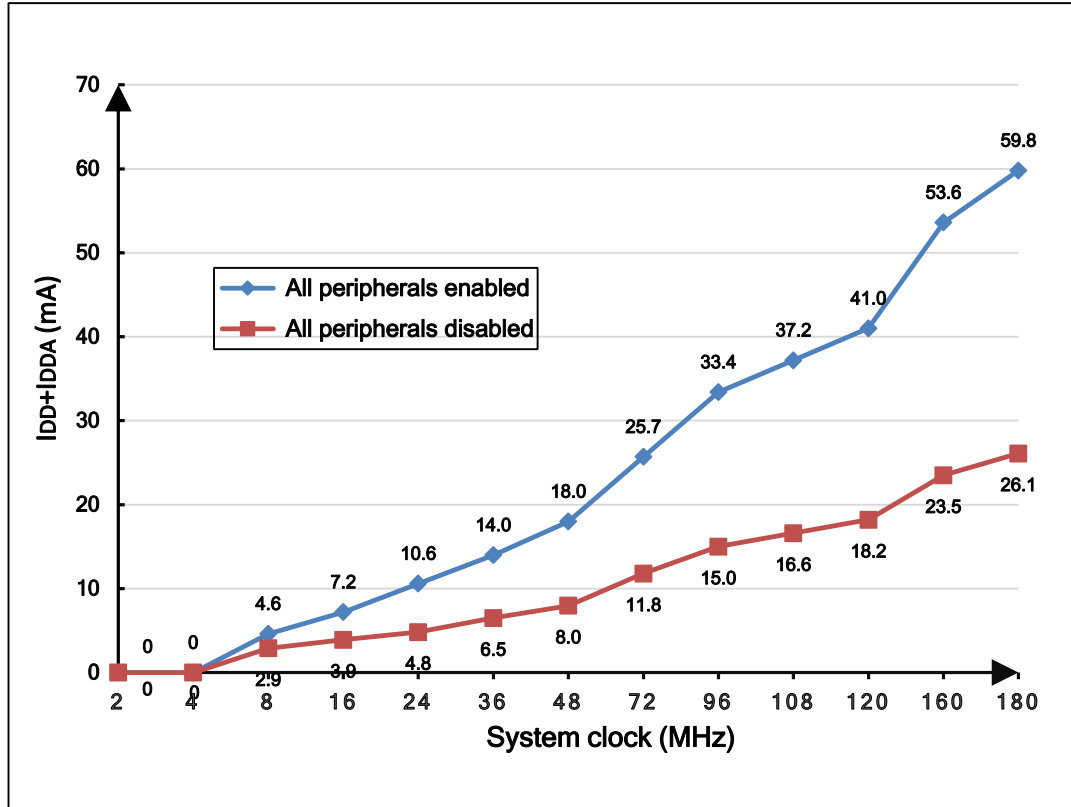
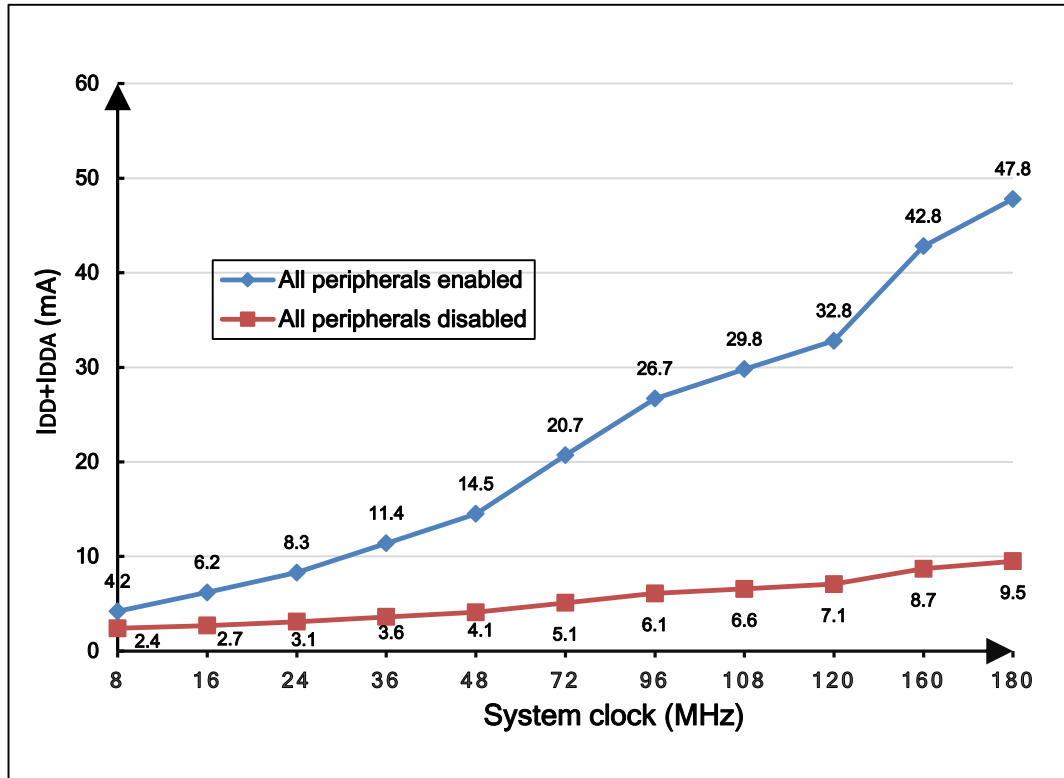

Figure 4-3. Typical supply current consumption in Sleep mode



4.4. EMC characteristics

EMI (Electromagnetic Interference) emission test result is given in the [Table 4-8. EMI characteristics^{\(1\)}](#). The electromagnetic field emitted by the device are monitored while an application, executing EEMBC code, is running. The test is compliant with SAE J1752-3:2017 standard which specifies the test board and the pin loading.

Table 4-8. EMI characteristics⁽¹⁾

Symbol	Parameter	Conditions	Tested frequency band	Max vs.	Unit
				[f _{HXTAL} /f _{HCLK}] 8/180 MHz	
S _{EMI}	Peak level	V _{DD} = 3.6 V, T _A = +23 °C, LQFP144, f _{HCLK} = 180 MHz, conforms to SAE J1752-3:2017	0.15 MHz to 30 MHz	-7.58	dBμV
			30 MHz to 130 MHz	3.35	
			130 MHz to 1 GHz	4.25	

(1) Based on characterization, not tested in production.

4.5. Power supply supervisor characteristics

Table 4-9. Power supply supervisor characteristics

Symbol	Parameter	Conditions	Min	Typ	Max	Unit
V _{LVD} ⁽¹⁾	Low voltage Detector level selection	LVDT<2:0> = 000(rising edge)	—	2.19	—	V
		LVDT<2:0> = 000(falling edge)	—	2.08	—	
		LVDT<2:0> = 001(rising edge)	—	2.33	—	
		LVDT<2:0> = 001(falling edge)	—	2.22	—	
		LVDT<2:0> = 010(rising edge)	—	2.48	—	
		LVDT<2:0> = 010(falling edge)	—	2.36	—	
		LVDT<2:0> = 011(rising edge)	—	2.62	—	
		LVDT<2:0> = 011(falling edge)	—	2.51	—	
		LVDT<2:0> = 100(rising edge)	—	2.75	—	
		LVDT<2:0> = 100(falling edge)	—	2.65	—	
		LVDT<2:0> = 101(rising edge)	—	2.9	—	
		LVDT<2:0> = 101(falling edge)	—	2.79	—	
		LVDT<2:0> = 110(rising edge)	—	3.04	—	
		LVDT<2:0> = 110(falling edge)	—	2.93	—	
LVDT<2:0> = 111(rising edge)	—	3.19	—			

Symbol	Parameter	Conditions	Min	Typ	Max	Unit
		LVDT<2:0> = 111(falling edge)	—	3.07	—	
V _{LVDhyst} ⁽²⁾	LVD hysteresis	—	—	100	—	mV
V _{POR} ⁽¹⁾	Power on reset threshold	—	—	1.56	—	V
V _{PDR} ⁽¹⁾	Power down reset threshold	—	—	1.52	—	V
V _{PDRhyst} ⁽²⁾	PDR hysteresis	—	—	40	—	mV
V _{BOR3} ⁽²⁾	Brownout level 3 threshold	Falling edge	—	2.8	—	V
		Rising edge	—	2.9	—	V
V _{BOR2} ⁽²⁾	Brownout level 2 threshold	Falling edge	—	2.5	—	V
		Rising edge	—	2.6	—	V
V _{BOR1} ⁽²⁾	Brownout level 1 threshold	Falling edge	—	2.2	—	V
		Rising edge	—	2.3	—	V
V _{BORhyst} ⁽²⁾	BOR hysteresis	—	—	100	—	mV
t _{RSTTEMPO} ⁽²⁾	Reset temporization	—	—	2.88	—	ms

(1) Based on characterization, not tested in production.

(2) Guaranteed by design, not tested in production.

4.6. Electrical sensitivity

The device is strained in order to determine its performance in terms of electrical sensitivity. Electrostatic discharges (ESD) are applied directly to the pins of the sample. Static latch-up (LU) test is based on the two measurement methods.

Table 4-10. ESD and static latch-up characteristics^{(1) (2) (3)}

Symbol	Parameter	Conditions	Level/Class	Min	Typ	Max	Unit
V _{ESD(HBM)} ⁽⁴⁾	Electrostatic discharge voltage (human body model)	T _A = 25 °C, LQFP144, Zap 3 pulse, Zap Interval = 500 ms	Class 2	—	—	±2000	V
V _{ESD(CDM)} ⁽⁵⁾	Electrostatic discharge voltage (charge device model)	All pins except the corner pins	Class C2A	—	—	±500	V
		Corner pins only		—	—	±750	V
LU ⁽⁶⁾	I-test	T _A = 125 °C, LQFP144	Class II A	—	—	±200	mA
	V _{supply} over voltage			—	—	5.4	V

(1) All ESD testing are in conformity with AEC-Q100 Stress Test Qualification for Automotive Grade Integrated Circuits.

(2) Device failure is defined as: "If after exposure to ESD pulses, the device does not meet the device specification requirements, which include the complete DC parametric and functional testing at room temperature and hot

temperature”.

- (3) Based on characterization, not tested in production.
- (4) This parameter is tested in conformity with AEC-Q100-002E.
- (5) This parameter is tested in conformity with AEC-Q100-011D.
- (6) This parameter is tested in conformity with AEC-Q100-004D.

4.7. External clock characteristics

Table 4-11. High speed external clock (HXTAL) generated from a crystal/ceramic characteristics

Symbol	Parameter	Conditions	Min	Typ	Max	Unit
$f_{\text{HXTAL}}^{(1)}$	Crystal or ceramic frequency	$1.71 \text{ V} \leq V_{\text{DD}} \leq 3.63 \text{ V}$	4	8	32	MHz
$R_{\text{F}}^{(2)}$	Feedback resistor	$V_{\text{DD}} = 3.3 \text{ V}$	—	400	—	k Ω
$C_{\text{HXTAL}}^{(2)(3)}$	Recommended load capacitance on OSCIN and OSCOUT	—	—	20	30	pF
$\text{Ducy}_{(\text{HXTAL})}^{(2)}$	Crystal or ceramic duty cycle	—	30	50	70	%
$g_{\text{m}}^{(2)}$	Oscillator transconductance	Startup	—	25	—	mA/V
$I_{\text{DDHXTAL}}^{(1)}$	Crystal or ceramic operating current	$V_{\text{DD}} = 3.3 \text{ V}$, $f_{\text{HCLK}} = f_{\text{IRC8M}} = 8 \text{ MHz}$ $T_{\text{A}} = 25 \text{ }^{\circ}\text{C}$	—	0.42	—	mA
$t_{\text{SUHXTAL}}^{(1)}$	Crystal or ceramic startup time	$V_{\text{DD}} = 3.3 \text{ V}$, $f_{\text{HCLK}} = f_{\text{IRC8M}} = 8 \text{ MHz}$ $T_{\text{A}} = 25 \text{ }^{\circ}\text{C}$	—	2	—	ms

- (1) Based on characterization, not tested in production.
- (2) Guaranteed by design, not tested in production.
- (3) $C_{\text{HXTAL1}} = C_{\text{HXTAL2}} = 2 \times (C_{\text{LOAD}} - C_{\text{S}})$, For C_{HXTAL1} and C_{HXTAL2} , it is recommended matching capacitance on OSCIN and OSCOUT. For C_{LOAD} , it is crystal/ceramic load capacitance, provided by the crystal or ceramic manufacturer. For C_{S} , it is PCB and MCU pin stray capacitance.

Table 4-12. High speed external clock characteristics (HXTAL in bypass mode)

Symbol	Parameter	Conditions	Min	Typ	Max	Unit
$f_{\text{HXTAL_ext}}^{(1)}$	External clock source or oscillator frequency	$1.71 \text{ V} \leq V_{\text{DD}} \leq 3.63 \text{ V}$	1	—	50	MHz
$V_{\text{HXTALH}}^{(2)}$	OSCIN input pin high level voltage	$V_{\text{DD}} = 3.3 \text{ V}$	$0.7 V_{\text{DD}}$	—	V_{DD}	V
$V_{\text{HXTALL}}^{(2)}$	OSCIN input pin low level voltage		V_{SS}	—	$0.3 V_{\text{DD}}$	V
$t_{\text{H/L(HXTAL)}}^{(2)}$	OSCIN high or low time	—	5	—	—	ns
$t_{\text{R/F(HXTAL)}}^{(2)}$	OSCIN rise or fall time	—	—	—	10	ns
$C_{\text{IN}}^{(2)}$	OSCIN input capacitance	—	—	5	—	pF
$\text{Ducy}_{(\text{HXTAL})}^{(2)}$	Duty cycle	—	40	—	60	%

- (1) Based on characterization, not tested in production.
- (2) Guaranteed by design, not tested in production.

Table 4-13. Low speed external clock (LXTAL) generated from a crystal/ceramic

characteristics

Symbol	Parameter	Conditions	Min	Typ	Max	Unit
$f_{LXTAL}^{(1)}$	Crystal or ceramic frequency	$V_{DD} = 3.3\text{ V}$	—	32.768	—	kHz
$C_{LXTAL}^{(2)(3)}$	Recommended matching capacitance on OSC32IN and OSC32OUT	—	—	10	—	pF
$D_{cyc(LXTAL)}^{(2)}$	Crystal or ceramic duty cycle	—	30	—	70	%
$g_m^{(2)}$	Oscillator transconductance	Lower driving capability	—	4	—	$\mu\text{A/V}$
		Medium low driving capability	—	6	—	
		Medium high driving capability	—	12	—	
		Higher driving capability	—	18	—	
$I_{DDLXTAL}^{(1)}$	Crystal or ceramic operating current	LXTALDRI[1:0] = 00	—	0.7	—	μA
		LXTALDRI[1:0] = 01	—	0.8	—	
		LXTALDRI[1:0] = 10	—	1.2	—	
		LXTALDRI[1:0] = 11	—	1.6	—	
$t_{SULXTAL}^{(1)(4)}$	Crystal or ceramic startup time	—	—	2	—	s

(1) Based on characterization, not tested in production.

(2) Guaranteed by design, not tested in production.

(3) $C_{LXTAL1} = C_{LXTAL2} = 2 * (C_{LOAD} - C_s)$, For C_{LXTAL1} and C_{LXTAL2} , it is recommended matching capacitance on SC32IN and OSC32OUT. For C_{LOAD} , it is crystal/ceramic load capacitance, provided by the crystal or ceramic manufacturer. For C_s , it is PCB and MCU pin stray capacitance.

(4) $t_{SULXTAL}$ is the startup time measured from the moment it is enabled (by software) to the 32.768 kHz oscillator stabilization flags is SET. This value varies significantly with the crystal manufacturer.

Table 4-14. Low speed external user clock characteristics (LXTAL in bypass mode)

Symbol	Parameter	Conditions	Min	Typ	Max	Unit
$f_{LXTAL_ext}^{(1)}$	External clock source or oscillator frequency	$V_{DD} = 3.3\text{ V}$	—	32.768	1000	kHz
$V_{LXTALH}^{(2)}$	OSC32IN input pin high level voltage	—	$0.7 V_{DD}$	—	V_{DD}	V
$V_{LXTALL}^{(2)}$	OSC32IN input pin low level voltage	—	V_{SS}	—	$0.3 V_{DD}$	
$t_{H/L(LXTAL)}^{(2)}$	OSC32IN high or low time	—	450	—	—	ns
$t_{R/F(LXTAL)}^{(2)}$	OSC32IN rise or fall time	—	—	—	50	
$C_{IN}^{(2)}$	OSC32IN input capacitance	—	—	5	—	pF
$D_{cyc(LXTAL)}^{(2)}$	Duty cycle	—	30	50	70	%

(1) Based on characterization, not tested in production.

(2) Guaranteed by design, not tested in production.

4.8. Internal clock characteristics

Table 4-15. High speed internal clock (IRC8M) characteristics

Symbol	Parameter	Conditions	Min	Typ	Max	Unit
f_{IRC8M}	High Speed Internal Oscillator (IRC8M) frequency	$V_{DD} = V_{DDA} = 3.3\text{ V}$	—	8	—	MHz
ACC_{IRC8M}	IRC8M oscillator Frequency accuracy, Factory-trimmed	$V_{DD} = V_{DDA} = 3.3\text{ V}$, $T_A = -40\text{ °C} \sim +105\text{ °C}^{(1)}$	—	-1.338 to 0.887	—	%
		$V_{DD} = V_{DDA} = 3.3\text{ V}$, $T_A = 25\text{ °C}$	-1.0	—	+1.0	%
	IRC8M oscillator Frequency accuracy, User trimming step ⁽¹⁾	—	—	0.5	—	%
$Ducy_{IRC8M}^{(2)}$	IRC8M oscillator duty cycle	$V_{DD} = V_{DDA} = 3.3\text{ V}$	45	50	55	%
$I_{DDAIRC8M}^{(1)}$	IRC8M oscillator operating current	$V_{DD} = V_{DDA} = 3.3\text{ V}$,	—	80	—	μA
$t_{SUIRC8M}^{(1)}$	IRC8M oscillator startup time	$V_{DD} = V_{DDA} = 3.3\text{ V}$,	—	1.5	—	μs

(1) Based on characterization, not tested in production.

(2) Guaranteed by design, not tested in production.

Table 4-16. Low speed internal clock (IRC40K) characteristics

Symbol	Parameter	Conditions	Min	Typ	Max	Unit
$f_{IRC40K}^{(1)}$	Low Speed Internal oscillator (IRC40K) frequency	$V_{DD} = V_{DDA} = 3.3\text{ V}$, $T_A = -40\text{ °C} \sim +85\text{ °C}$	20	40	45	kHz
$I_{DDAIRC40K}^{(2)}$	IRC40K oscillator operating current	$V_{DD} = V_{DDA} = 3.3\text{ V}$, $f_{HCLK} = f_{HXTAL_PLL} = 180\text{ MHz}$ $T_A = 25\text{ °C}$	—	0.4	—	μA
$t_{SUIRC40K}^{(2)}$	IRC40K oscillator startup time	$V_{DD} = V_{DDA} = 3.3\text{ V}$, $f_{HCLK} = f_{HXTAL_PLL} = 180\text{ MHz}$ $T_A = 25\text{ °C}$	—	80	—	μs

(1) Guaranteed by design, not tested in production.

(2) Based on characterization, not tested in production.

Table 4-17. High speed internal clock (IRC48M) characteristics

Symbol	Parameter	Conditions	Min	Typ	Max	Unit
f_{IRC48M}	High Speed Internal Oscillator (IRC48M) frequency	$V_{DD} = 3.3\text{ V}$	—	48	—	MHz
ACC_{IRC48M}	IRC48M oscillator Frequency accuracy, Factory-trimmed	$V_{DD} = V_{DDA} = 3.3\text{ V}$, $T_A = -40\text{ }^{\circ}\text{C} \sim +105\text{ }^{\circ}\text{C}^{(1)}$	—	-2.871 to 1.023	—	%
		$V_{DD} = V_{DDA} = 3.3\text{ V}$, $T_A = 25\text{ }^{\circ}\text{C}$	-2.0	—	+2.0	%
	IRC48M oscillator Frequency accuracy, User trimming step ⁽¹⁾	—	—	0.12	—	%
$D_{IRC48M}^{(2)}$	IRC48M oscillator duty cycle	$V_{DD} = V_{DDA} = 3.3\text{ V}$	45	50	55	%
$I_{DDAIRC48M}^{(1)}$	IRC48M oscillator operating current	$V_{DD} = V_{DDA} = 3.3\text{ V}$, $f_{HCLK} = f_{HXTAL_PLL} = 180\text{ MHz}$	—	286.9	—	μA
$t_{SUIIRC48M}^{(1)}$	IRC48M oscillator startup time	$V_{DD} = V_{DDA} = 3.3\text{ V}$, $f_{HCLK} = f_{HXTAL_PLL} = 180\text{ MHz}$	—	3.68	—	μs

(1) Based on characterization, not tested in production.

(2) Guaranteed by design, not tested in production.

4.9. PLL characteristics

Table 4-18. PLL characteristics

Symbol	Parameter	Conditions	Min	Typ	Max	Unit
$f_{PLLIN}^{(1)}$	PLL input clock frequency	—	2	—	16	MHz
$f_{PLLOUT}^{(2)}$	PLL output clock frequency	—	16	—	180	MHz
$f_{VCO}^{(2)}$	PLL VCO output clock frequency	—	32	—	360	MHz
$t_{LOCK}^{(2)}$	PLL lock time	—	—	—	300	μs
$I_{DDA}^{(1)(3)}$	Current consumption on V_{DDA}	VCO freq = 360 MHz	—	700	—	μA
$I_{DD}^{(1)(3)}$	Current consumption on V_{DD}	VCO freq = 360 MHz	—	500	—	μA
$Jitter_{PLL}^{(1)(4)}$	Cycle to cycle Jitter (rms)	System clock	—	40	—	ps
	Cycle to cycle Jitter (peak to peak)		—	400	—	

(1) Based on characterization, not tested in production.

(2) Guaranteed by design, not tested in production.

(3) System clock = IRC8M = 8 MHz, PLL clock source = IRC8M/2 = 4 MHz, $f_{PLLOUT} = 180\text{ MHz}$.

(4) Value given with main PLL running.

Table 4-19. PLL1 characteristics

Symbol	Parameter	Conditions	Min	Typ	Max	Unit
$f_{PLLIN}^{(1)}$	PLL input clock frequency	—	2	—	16	MHz
$f_{PLLOUT}^{(2)}$	PLL output clock frequency	—	16	—	100	MHz
$f_{VCO}^{(2)}$	PLL VCO output clock frequency	—	32	—	180	MHz
$t_{LOCK}^{(2)}$	PLL lock time	—	—	—	300	μ s
$I_{DDA}^{(1)}$	Current consumption on V_{DDA}	VCO freq = 180 MHz	—	400	—	μ A
$I_{DD}^{(1)}$	Current consumption on V_{DD}	VCO freq = 180 MHz	—	250	—	μ A
$Jitter_{PLL}^{(1)}$	Cycle to cycle Jitter	—	—	40	—	ps

(1) Based on characterization, not tested in production.

(2) Guaranteed by design, not tested in production.

Table 4-20. PLL2 characteristics

Symbol	Parameter	Conditions	Min	Typ	Max	Unit
$f_{PLLIN}^{(1)}$	PLL input clock frequency	—	2	—	16	MHz
$f_{PLLOUT}^{(2)}$	PLL output clock frequency	—	16	—	180	MHz
$f_{VCO}^{(2)}$	PLL VCO output clock frequency	—	32	—	360	MHz
$t_{LOCK}^{(2)}$	PLL lock time	—	—	—	300	μ s
$I_{DDA}^{(1)}$	Current consumption on V_{DDA}	VCO freq = 360 MHz	—	700	—	μ A
$I_{DD}^{(1)}$	Current consumption on V_{DD}	VCO freq = 360 MHz	—	500	—	μ A
$Jitter_{PLL}^{(1)}$	Cycle to cycle Jitter	—	—	40	—	ps

(1) Based on characterization, not tested in production.

(2) Guaranteed by design, not tested in production.

Table 4-21. PLLUSB characteristics

Symbol	Parameter	Conditions	Min	Typ	Max	Unit
$f_{PLLIN}^{(1)}$	PLL input clock frequency	—	4	—	30	MHz
$f_{PLLOUT}^{(2)}$	PLL output clock frequency	—	—	480	—	MHz
$t_{LOCK}^{(2)}$	PLL lock time	—	—	100	150	μ s
$Jitter_{PLL}^{(2)}$	Cycle to cycle Jitter	System clock	—	40	—	ps
	Cycle to cycle Jitter (peak to peak)		—	400	—	

(1) Based on characterization, not tested in production.

(2) Guaranteed by design, not tested in production.

Table 4-22. PLL spread spectrum clock generation (SSCG) characteristics ⁽¹⁾

Symbol	Parameter	Conditions	Min	Typ	Max	Unit
f_{mod}	Modulation frequency	—	—	—	10	KHz
mdamp	Peak modulation amplitude	—	—	—	2	%
MODCNT*	—	—	—	—	$2^{15}-1$	—
MODSTEP	—	—	—	—	—	—

(1) Guaranteed by design, not tested in production.

Equation 1: SSCG configuration equation:

$$MODCNT = \text{round}(f_{PLLIN}/4/f_{mod})$$

$$\text{MODSTEP} = \text{round}(\text{mdamp} * \text{PLLN} * 2^{15} / (\text{MODCNT} * 100))$$

The formula above ([Equation 1](#)) is SSCG configuration equation.

4.10. Memory characteristics

Table 4-23. Flash memory characteristics

Symbol	Parameter	Conditions	Min ⁽¹⁾	Typ ⁽¹⁾	Max	Unit
PE _{CYC}	Number of guaranteed program /erase cycles before failure (Endurance)	T _A = -40 °C ~ +105 °C	10	—	—	kcycles
t _{RET}	Data retention time	T _A = -40 °C ~ +105 °C	10	—	—	years
t _{PROG}	Word programming time	T _A = -40 °C ~ +105 °C	—	37.5	—	μs
t _{ERASE}	Page erase time	T _A = -40 °C ~ +105 °C	—	11	—	ms
t _{MERASE}	Mass erase time	T _A = -40 °C ~ +105 °C	—	12	—	ms

(1) Based on characterization, not tested in production.

4.11. NRST pin characteristics

Table 4-24. NRST pin characteristics

Symbol	Parameter	Conditions	Min	Typ	Max	Unit
V _{IL(NRST)} ⁽¹⁾	NRST Input low level voltage	V _{DD} = V _{DDA} = 1.71 V	—	—	0.35 V _{DD}	V
V _{IH(NRST)} ⁽¹⁾	NRST Input high level voltage		0.65 V _{DD}	—	—	
V _{hyst} ⁽¹⁾	Schmidt trigger Voltage hysteresis		—	120	—	
V _{IL(NRST)} ⁽¹⁾	NRST Input low level voltage	V _{DD} = V _{DDA} = 3.3 V	—	—	0.35 V _{DD}	V
V _{IH(NRST)} ⁽¹⁾	NRST Input high level voltage		0.65 V _{DD}	—	—	
V _{hyst} ⁽¹⁾	Schmidt trigger Voltage hysteresis		—	180	—	
V _{IL(NRST)} ⁽¹⁾	NRST Input low level voltage	V _{DD} = V _{DDA} = 3.63 V	—	—	0.35 V _{DD}	V
V _{IH(NRST)} ⁽¹⁾	NRST Input high level voltage		0.65 V _{DD}	—	—	
V _{hyst} ⁽¹⁾	Schmidt trigger Voltage hysteresis		—	200	—	
R _{pu} ⁽²⁾	Pull-up equivalent resistor	—	—	40	—	kΩ

(1) Based on characterization, not tested in production.

(2) Guaranteed by design, not tested in production.

Figure 4-4. Recommended external NRST pin circuit⁽¹⁾

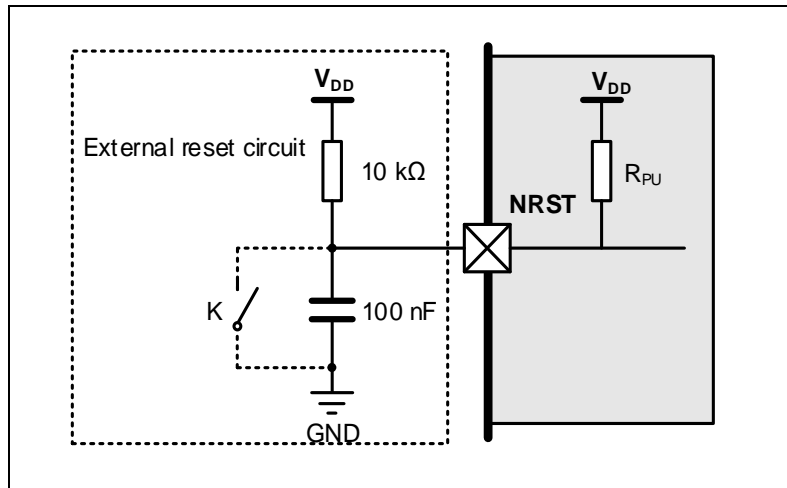

(1) Unless the voltage on NRST pin go below $V_{IL(NRST)}$ level, the device would not generate a reliable reset.

4.12. GPIO characteristics

Table 4-25. I/O port DC characteristics ⁽¹⁾⁽³⁾

Symbol	Parameter	Conditions	Min	Typ	Max	Unit
V_{IL}	Standard IO Low level input voltage	$1.71\text{ V} \leq V_{DD} = V_{DDA} \leq 3.63\text{ V}$	—	—	$0.35 V_{DD}$	V
	5V-tolerant IO Low level input voltage	$1.71\text{ V} \leq V_{DD} = V_{DDA} \leq 3.63\text{ V}$	—	—	$0.35 V_{DD}$	V
V_{IH}	Standard IO High level input voltage	$1.71\text{ V} \leq V_{DD} = V_{DDA} \leq 3.63\text{ V}$	0.65 V_{DD}	—	—	V
	5V-tolerant IO High level input voltage	$1.71\text{ V} \leq V_{DD} = V_{DDA} \leq 3.63\text{ V}$	0.65 V_{DD}	—	—	V
V_{OL}	Low level output voltage for an IO Pin ($I_{IO} = +8\text{ mA}$)	$V_{DD} = 1.71\text{V}$	—	—	0.19	V
		$V_{DD} = 3.3\text{ V}$	—	—	0.12	
		$V_{DD} = 3.63\text{V}$	—	—	0.11	
V_{OL}	Low level output voltage for an IO Pin ($I_{IO} = +20\text{ mA}$)	$V_{DD} = 1.71\text{V}$	—	—	0.61	V
		$V_{DD} = 3.3\text{ V}$	—	—	0.3	
		$V_{DD} = 3.63\text{V}$	—	—	0.29	
V_{OH}	High level output voltage for an IO Pin ($I_{IO} = +8\text{ mA}$)	$V_{DD} = 1.71\text{V}$	1.48	—	—	V
		$V_{DD} = 3.3\text{ V}$	3.17	—	—	
		$V_{DD} = 3.63\text{V}$	3.47	—	—	
V_{OH}	High level output voltage for an IO Pin ($I_{IO} = +20\text{ mA}$)	$V_{DD} = 1.71\text{V}$	—	—	—	V
		$V_{DD} = 3.3\text{ V}$	2.96	—	—	
		$V_{DD} = 3.63\text{V}$	3.26	—	—	
$R_{PU}^{(2)}$	Internal pull-up resistor	All pins	—	—	40	kΩ
		PA10	—	—	10	
$R_{PD}^{(2)}$	Internal pull-down resistor	All pins	—	—	40	kΩ
		PA10	—	—	10	

- (1) Based on characterization, not tested in production.
- (2) Guaranteed by design, not tested in production.
- (3) All pins except PC13 / PC14 / PC15. Since PC13 to PC15 are supplied through the Power Switch, which can only be obtained by a small current(typical source capability:3 mA shared between these IOs, but sink capability is same as other IO), the speed of GPIOs PC13 to PC15 should not exceed 2 MHz when they are in output mode(maximum load: 30 pF).

Table 4-26. I/O port AC characteristics ⁽¹⁾⁽²⁾⁽⁴⁾

GPIOx_MDy[1:0] bit value ⁽³⁾	Parameter	Conditions	Max	Unit
GPIOx_CTL->MDy[1:0]=10 (IO_Speed = 2 MHz)	Maximum frequency	1.8 ≤ V _{DD} ≤ 3.63 V, C _L = 10 pF	4	MHz
		1.8 ≤ V _{DD} ≤ 3.63 V, C _L = 30 pF	3	
		1.8 ≤ V _{DD} ≤ 3.63 V, C _L = 50 pF	2	
GPIOx_CTL->MDy[1:0] = 01 (IO_Speed = 10 MHz)	Maximum frequency	1.8 ≤ V _{DD} ≤ 3.63 V, C _L = 10 pF	60	MHz
		1.8 ≤ V _{DD} ≤ 3.63 V, C _L = 30 pF	30	
		1.8 ≤ V _{DD} ≤ 3.63 V, C _L = 50 pF	12	
GPIOx_CTL->MDy[1:0]=11 (IO_Speed = 50 MHz)	Maximum frequency	1.8 ≤ V _{DD} ≤ 3.63 V, C _L = 10 pF	100	MHz
		1.8 ≤ V _{DD} ≤ 3.63 V, C _L = 30 pF	80	
		1.8 ≤ V _{DD} ≤ 3.63 V, C _L = 50 pF	60	
GPIOx_CTL->MDy[1:0]=11 and GPIOx_SPDy=1 (IO_Speed = MAX)	Maximum frequency	1.8 ≤ V _{DD} ≤ 3.63 V, C _L = 10 pF	120	MHz
		1.8 ≤ V _{DD} ≤ 3.63 V, C _L = 30 pF	100	
		1.8 ≤ V _{DD} ≤ 3.63 V, C _L = 50 pF	80	

- (1) Based on characterization, not tested in production.
- (2) Unless otherwise specified, all test results given for T_A = 25 °C.
- (3) The I/O speed is configured using the GPIOx_CTL -> MDy[1:0] bits. Refer to the GD32A508xx user manual which is selected to set the GPIO port output speed.
- (4) Only for reference, Depending on user's design.

4.13. Temperature sensor characteristics

Table 4-27. Temperature sensor characteristics ⁽¹⁾

Symbol	Parameter	Min	Typ	Max	Unit
V _{DD}	Supply voltage	1.8	—	3.63	V
V _{DDA}	Analog supply voltage	1.8	—	3.63	
V _{REFP}	Positive Reference Voltage	1.8	—	V _{DDA}	
V _{REFN}	Negative Reference Voltage	—	V _{SSA}	—	
T _L	VSENSE linearity with temperature	—	±1.5	—	°C
Avg_Slope	Average slope	—	4.1	—	mV/°C
V ₂₅	Voltage at 25 °C	—	1.45	—	V
t _{S_temp} ⁽²⁾	ADC sampling time when reading the temperature	—	17.1	—	µs

- (1) Based on characterization, not tested in production.
- (2) Shortest sampling time can be determined in the application by multiple iterations.

4.14. ADC characteristics

Table 4-28. ADC characteristics

Symbol	Parameter	Conditions	Min	Typ	Max	Unit
V _{DDA} ⁽¹⁾	Operating voltage	—	1.71	3.3	3.63	V
V _{IN} ⁽¹⁾	ADC input voltage range	—	0	—	V _{REFP}	V
V _{REFP} ⁽²⁾⁽³⁾	Positive Reference Voltage	—	1.71	—	V _{DDA}	V
V _{REFN} ⁽²⁾	Negative Reference Voltage	—	—	V _{SSA}	—	V
f _{ADC} ⁽¹⁾	ADC clock	V _{DDA} = 1.71 V to 2.4 V	0.1	—	14	MHz
		V _{DDA} = 2.4 V to 3.63 V	0.1	—	35	MHz
f _s ⁽¹⁾	Sampling rate	12-bit	0.007	—	2.5	MSP
		10-bit	0.008	—	2.92	
		8-bit	0.01	—	3.5	S
		6-bit	0.013	—	4.38	
V _{AIN} ⁽¹⁾	Analog input voltage	16 external; 2 internal	0	—	V _{DDA}	V
R _{AIN} ⁽²⁾	External input impedance	See Equation 2	—	—	175.8	kΩ
R _{ADC} ⁽²⁾	Input sampling switch resistance	—	—	—	0.5	kΩ
C _{ADC} ⁽²⁾	Input sampling capacitance	No pin/pad capacitance included	—	—	4	pF
t _{CAL} ⁽²⁾	Calibration time	f _{ADC} = 35 MHz	—	15.94	—	μs
t _s ⁽²⁾	Sampling time	f _{ADC} = 35 MHz	0.043	—	6.84	μs
t _{CONV} ⁽²⁾	Total conversion time(including sampling time)	12-bit	—	14	—	1/ f _{ADC}
		10-bit	—	12	—	
		8-bit	—	10	—	
		6-bit	—	8	—	
t _{SU} ⁽²⁾	Startup time	—	—	—	1	μs

(1) Based on characterization, not tested in production.

(2) Guaranteed by design, not tested in production.

(3) V_{REFP} should always be equal to or less than V_{DDA}, especially during power up.

Equation 2:

$$R_{AIN \max} \text{ formula } R_{AIN} < \frac{T_s}{f_{ADC} * C_{ADC} * \ln(2^{N+2})} - R_{ADC}$$

The formula above (Equation 2) is used to determine the maximum external impedance allowed for an error below 1/4 of LSB. Here N = 12 (from 12-bit resolution).

Table 4-29. ADC R_{AIN} max for f_{ADC} = 35 MHz

T _s (cycles)	t _s (μs)	R _{AIN} max (kΩ)
1.5	0.043	0.6
7.5	0.21	5.0
13.5	0.39	9.4
28.5	0.81	20.5

T_s (cycles)	t_s (μ s)	$R_{AIN\ max}$ (k Ω)
41.5	1.19	30.0
55.5	1.59	40.0
71.5	2.04	52.0
239.5	6.84	175.8

Table 4-30. ADC dynamic accuracy at $f_{ADC} = 14$ MHz $V_{DDA} = 1.8$ V⁽¹⁾

Symbol	Parameter	Test conditions	Min	Typ	Max	Unit	
ENOB	Effective number of bits	$f_{ADC} = 14$ MHz $V_{DDA} = V_{REFP} = 1.8$ V Input Frequency = 20 kHz Temperature = 25 °C	Single ended	10.4	10.8	—	bits
			Differential	10.9	11.3	—	
SNDR	Signal-to-noise and distortion ratio		Single ended	64.4	66.8	—	dB
			Differential	67.5	69.9	—	
SNR	Signal-to-noise ratio		Single ended	64.5	66.9	—	
			Differential	67.6	70.2	—	
THD	Total harmonic distortion		Single ended	—	-81	-78	
			Differential	—	-82	-79	

(1) Based on characterization, not tested in production.

Table 4-31. ADC dynamic accuracy at $f_{ADC} = 35$ MHz $V_{DDA} = 3.3$ V⁽¹⁾

Symbol	Parameter	Test conditions	Min	Typ	Max	Unit	
ENOB	Effective number of bits	$f_{ADC} = 35$ MHz $V_{DDA} = V_{REFP} = 3.3$ V Input Frequency = 20 kHz Temperature = 25 °C	Single ended	10.7	11.1	—	bits
			Differential	11	11.4	—	
SNDR	Signal-to-noise and distortion ratio		Single ended	66.2	68.6	—	dB
			Differential	68.2	70.6	—	
SNR	Signal-to-noise ratio		Single ended	66	68.8	—	
			Differential	68	71	—	
THD	Total harmonic distortion		Single ended	—	-82	-78	
			Differential	—	-83	-79	

(1) Based on characterization, not tested in production.

Table 4-32. ADC dynamic accuracy at $f_{ADC} = 35$ MHz $V_{DDA} = 2.4$ V⁽¹⁾

Symbol	Parameter	Test conditions	Min	Typ	Max	Unit	
ENOB	Effective number of bits	$f_{ADC} = 35$ MHz $V_{DDA} = V_{REFP} = 2.4$ V Input Frequency = 20 kHz Temperature = 25 °C	Single ended	10.6	11	—	bits
			Differential	11	11.4	—	
SNDR	Signal-to-noise and distortion ratio		Single ended	66	68.3	—	dB
			Differential	68	70.4	—	
SNR	Signal-to-noise ratio		Single ended	65	68.5	—	
			Differential	67	70.8	—	
THD	Total harmonic distortion		Single ended	—	-82	-78	
			Differential	—	-83	-79	

(1) Based on characterization, not tested in production.

Table 4-33. ADC static accuracy at $f_{ADC} = 14$ MHz $V_{DDA} = 1.8$ V⁽¹⁾

Symbol	Parameter	Test conditions	Typ	Max	Unit	
Offset	Offset error	$f_{ADC} = 14$ MHz $V_{DDA} = V_{REFP} = 1.8$ V	Single ended	± 0.5	± 1	LSB
			Differential	± 0.5	± 1	

DNL	Differential linearity error	Temperature = 25 °C	Single ended	±0.5	±1	
			Differential	±0.6	±1	
INL	Integral linearity error		Single ended	±0.6	±1	
			Differential	±0.8	±1.5	

(1) Based on characterization, not tested in production.

Table 4-34. ADC static accuracy at $f_{ADC} = 35$ MHz $V_{DDA} = 3.3$ V ⁽¹⁾

Symbol	Parameter	Test conditions	Typ	Max	Unit	
Offset	Offset error	$f_{ADC} = 35$ MHz $V_{DDA} = V_{REFP} = 3.3$ V Temperature = 25 °C	Single ended	±0.5	±1	LSB
			Differential	±0.5	±1	
DNL	Differential linearity error		Single ended	±0.5	±0.8	
			Differential	±0.7	±1	
INL	Integral linearity error		Single ended	±0.7	±1	
			Differential	±0.9	±1.5	

(1) Based on characterization, not tested in production.

Table 4-35. ADC static accuracy at $f_{ADC} = 35$ MHz $V_{DDA} = 2.4$ V ⁽¹⁾

Symbol	Parameter	Test conditions	Typ	Max	Unit	
Offset	Offset error	$f_{ADC} = 35$ MHz $V_{DDA} = V_{REFP} = 2.4$ V Temperature = 25 °C	Single ended	±0.5	±1	LSB
			Differential	±0.5	±1	
DNL	Differential linearity error		Single ended	±0.5	±0.8	
			Differential	±0.6	±1	
INL	Integral linearity error		Single ended	±0.6	±1	
			Differential	±0.8	±1.5	

(1) Based on characterization, not tested in production.

4.15. DAC characteristics

Table 4-36. DAC characteristics

Symbol	Parameter	Conditions	Min	Typ	Max	Unit
V _{DDA} ⁽¹⁾	Operating voltage	—	1.8	3.3	3.63	V
V _{REFP} ⁽²⁾	Positive Reference Voltage	—	1.8	—	V _{DDA}	V
V _{REFN} ⁽²⁾	Negative Reference Voltage	—	—	V _{SSA}	—	V
R _{LOAD} ⁽²⁾	Load resistance	Resistive load with buffer ON	5	—	—	kΩ
R _o ⁽²⁾	Impedance output with buffer OFF	—	—	—	15	kΩ
C _{LOAD} ⁽²⁾	Load capacitance	No pin/pad capacitance included	—	—	50	pF
DAC_OUT min ⁽²⁾	Lower DAC_OUT voltage with buffer ON	—	0.2	—	—	V
DAC_OUT max ⁽²⁾	Higher DAC_OUT voltage with buffer ON	—	—	—	V _{DDA} -0.2	V
DAC_OUT min ⁽²⁾	Lower DAC_OUT voltage with buffer OFF	—	—	0.5	—	mV
DAC_OUT max ⁽²⁾	Higher DAC_OUT voltage with buffer OFF	—	—	—	V _{REF} -1LSB	V
I _{DDA} ⁽¹⁾	DAC current consumption in quiescent mode	With no load, middle code(0x800) on the input, V _{REFP} = 3.63 V	—	400	—	μA
		With no load, worst code(0xF1C) on the input, V _{REFP} = 3.63 V	—	450	—	μA
I _{DDVREFP} ⁽¹⁾	DAC current consumption in quiescent mode	With no load, middle code(0x800) on the input, V _{REFP} = 3.63 V	—	100	—	μA
		With no load, worst code(0xF1C) on the input, V _{REFP} = 3.63 V	—	150	—	μA
DNL ⁽¹⁾	Differential non-linearity error	DAC in 12-bit mode	—	—	±2	LSB
INL ⁽¹⁾	Integral non-linearity	DAC in 12-bit mode	—	—	±4	LSB
Offset ⁽¹⁾	Offset error	DAC in 12-bit mode	—	—	10	LSB
GE ⁽¹⁾	Gain error	DAC in 12-bit mode	—	—	0.5	%
T _{setting} ⁽¹⁾	Settling time	C _{LOAD} ≤ 50 pF, R _{LOAD} ≥ 5 kΩ	—	—	0.5	μs
T _{wakeup} ⁽²⁾	Wakeup from off state	—	—	—	5	μs
Update rate ⁽²⁾	Max frequency for a correct DAC_OUT change from code i to i±1LSBs	C _{LOAD} ≤ 50 pF, R _{LOAD} ≥ 5 kΩ	—	—	4	MS/s
PSRR ⁽²⁾	Power supply rejection ratio	—	55	80	—	dB

Symbol	Parameter	Conditions	Min	Typ	Max	Unit
	(to V _{DDA})					

- (1) Based on characterization, not tested in production.
(2) Guaranteed by design, not tested in production.

4.16. Comparators characteristics

Table 4-37. CMP characteristics ⁽¹⁾

Symbol	Parameter	Conditions	Min	Typ	Max	Unit
t _{SU}	Setup Time	—	—	5.5	—	μs
V _{OS}	Offset Voltage	—	—	2	—	mV
t _D	Propagation delay	V _{STEP} = 200 mV	—	24	—	ns
		Full Range	—	30	—	
I _{VDD}	Current consumption	—	—	360	—	μA
I _{LEAK}	Leakage Current	—	—	1	—	nA

- (1) Guaranteed by design, not tested in production.

4.17. Trigonometric Math Unit (TMU) characteristics

The TMU unit has 9 different operation modes.

Table 4-38. TMU supported instructions characteristics ⁽¹⁾

Mode Number	Operation	Cycles
0	R0 = x * 2π	4
1	R0 = x/2π	4
2	R0 = √x	7
3	R0 = sin(x)	7
4	R0 = cos(x)	7
5	R0 = arctan(x)	7
6	R0 = Ratio of X & Y, R1 = Quadrant value (0.0, ±0.25, ±0.5)	7
7	R0 = x/y	7
8	R0 = √x ² +y ²	7

- (1) Guaranteed by design, not tested in production.

4.18. I2C characteristics

Table 4-39. I2C characteristics ⁽¹⁾⁽²⁾⁽³⁾

Symbol	Parameter	Conditions	Standard mode		Fast mode		Fast mode plus		Unit
			Min	Max	Min	Max	Min	Max	
$t_{SCL(H)}$	SCL clock high time	—	4.0	—	0.6	—	0.2	—	μ s
$t_{SCL(L)}$	SCL clock low time	—	4.7	—	1.3	—	0.5	—	μ s
$t_{su(SDA)}$	SDA setup time	—	2	—	0.8	—	0.1	—	ns
$t_h(SDA)$	SDA data hold time	—	0	—	0	—	0	—	ns
$t_r(SDA/SCL)$	SDA and SCL rise time	—	—	1000	20	300	—	120	ns
$t_f(SDA/SCL)$	SDA and SCL fall time	—	—	300	—	300	—	120	ns
$t_h(STA)$	Start condition hold time	—	4.0	—	0.6	—	0.26	—	μ s

- (1) Guaranteed by design, not tested in production.
- (2) To ensure the standard mode I2C frequency, f_{PCLK1} must be at least 2 MHz, To ensure the fast mode I2C frequency, f_{PCLK1} must be at least 4 MHz. To ensure the fast mode plus I2C frequency, f_{PCLK1} must be at least a multiple of 10 MHz.
- (3) The device should provide a data hold time of 300 ns at least in order to bridge the undefined region of the falling edge of SCL.

Figure 4-5. I2C bus timing diagram

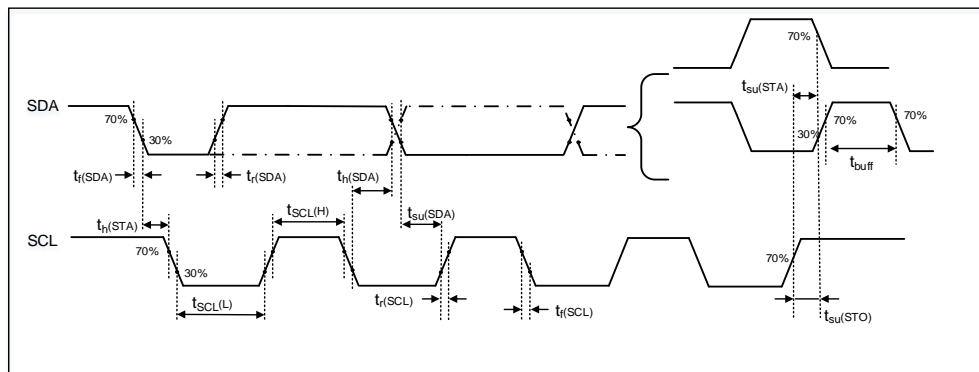

Table 4-40. I2C analog filter delay characteristics⁽¹⁾

Symbol	Parameter	Conditions	Min	Typ	Max	Unit
t_{AF}	Analog filter delay time	—	50	75	160	ns

- (1) Guaranteed by design, not tested in production.

4.19. SPI characteristics

Table 4-41. Standard SPI characteristics ⁽¹⁾

Symbol	Parameter	Conditions	Min	Typ	Max	Unit
--------	-----------	------------	-----	-----	-----	------

f_{SCK}	SCK clock frequency	—	—	—	22.5	MHz
$t_{SCK(H)}$	SCK clock high time	Master mode, $f_{PCLKX} = 90$ MHz, presc = 4	—	22.2	—	ns
$t_{SCK(L)}$	SCK clock low time	Master mode, $f_{PCLKX} = 90$ MHz, presc = 4	—	22.2	—	ns
SPI master mode						
$t_{V(MO)}$	Data output valid time	—	—	—	10	ns
$t_{SU(MI)}$	Data input setup time	—	1	—	—	ns
$t_{H(MI)}$	Data input hold time	—	0	—	—	ns
SPI slave mode						
$t_{SU(NSS)}$	NSS enable setup time	—	0	—	—	ns
$t_{H(NSS)}$	NSS enable hold time	—	1	—	—	ns
$t_{A(SO)}$	Data output access time	—	—	10	—	ns
$t_{DIS(SO)}$	Data output disable time	—	—	11	—	ns
$t_{V(SO)}$	Data output valid time	—	—	11	—	ns
$t_{SU(SI)}$	Data input setup time	—	0	—	—	ns
$t_{H(SI)}$	Data input hold time	—	1	—	—	ns

(1) Based on characterization, not tested in production.

Figure 4-6. SPI timing diagram - master mode

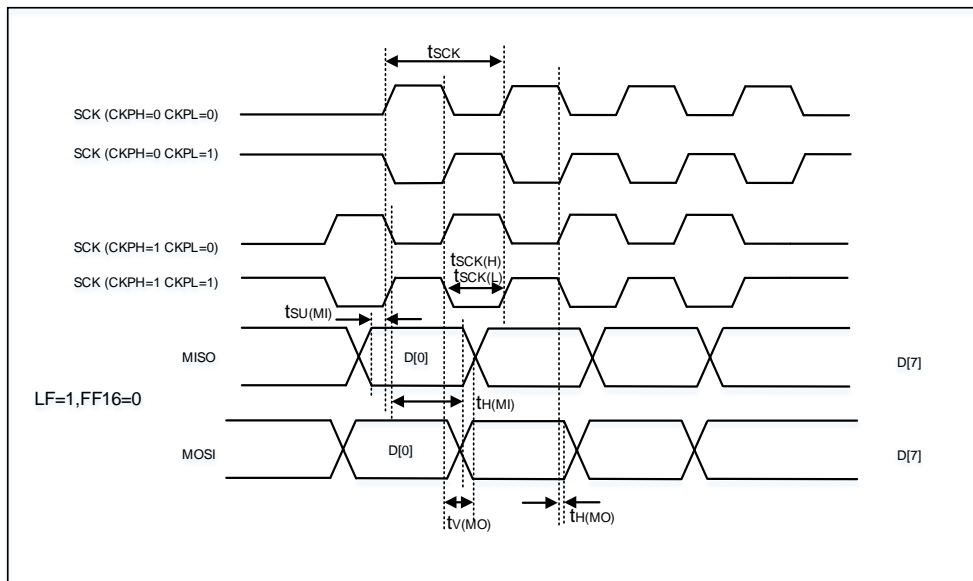
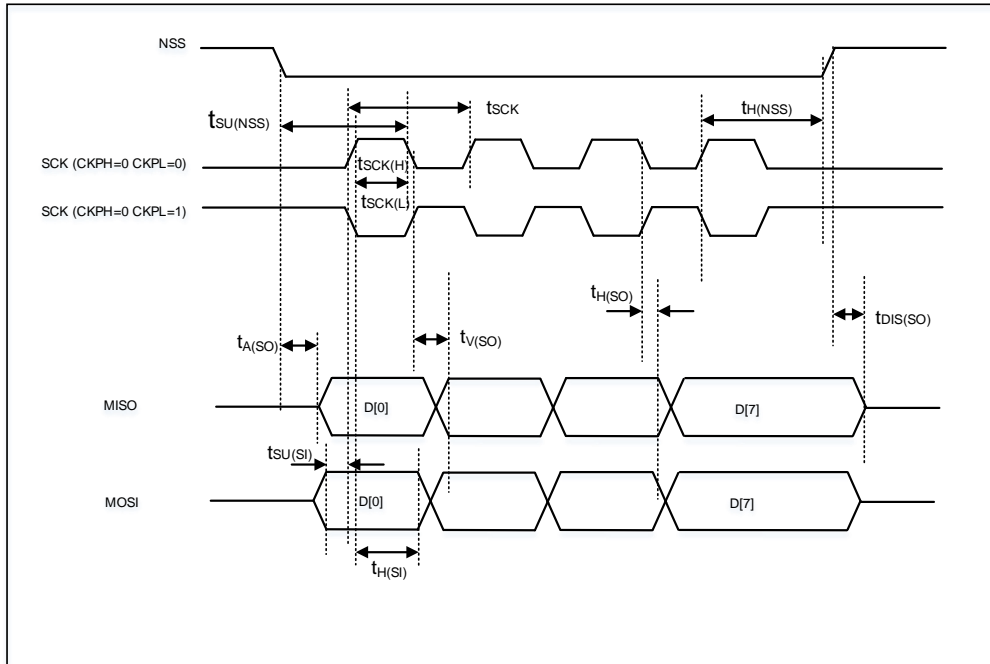

Figure 4-7. SPI timing diagram - slave mode



4.20. I2S characteristics

Table 4-42. I2S characteristics ⁽¹⁾⁽²⁾

Symbol	Parameter	Conditions	Min	Typ	Max	Unit
f _{CK}	Clock frequency	Master mode (data: 32 bits, Audio frequency = 96 kHz)	—	6.21	—	MHz
		Slave mode	—	—	12.5	
t _H	Clock high time	—	—	81	—	ns
t _L	Clock low time		—	81	—	ns
t _{V(WS)}	WS valid time	Master mode	—	3	—	ns
t _{H(WS)}	WS hold time	Master mode	—	3	—	ns
t _{SU(WS)}	WS setup time	Slave mode	0	—	—	ns
t _{H(WS)}	WS hold time	Slave mode	2	—	—	ns
Ducy _(SCK)	I2S slave input clock duty cycle	Slave mode	—	50	—	%
t _{SU(SD_MR)}	Data input setup time	Master mode	1	—	—	ns
t _{SU(SD_SR)}	Data input setup time	Slave mode	0	—	—	ns
t _{H(SD_MR)}	Data input hold time	Master receiver	0	—	—	ns
t _{H(SD_SR)}		Slave receiver	1	—	—	ns
t _{V(SD_ST)}	Data output valid time	Slave transmitter (after enable edge)	—	—	10	ns
t _{H(SD_ST)}	Data output hold time	Slave transmitter (after enable edge)	3	—	—	ns
t _{V(SD_MT)}	Data output valid time	Master transmitter (after enable edge)	—	—	10	ns
t _{H(SD_MT)}	Data output hold time	Master transmitter (after enable edge)	0	—	—	ns

(1) Guaranteed by design, not tested in production.

(2) Based on characterization, not tested in production

Figure 4-8. I2S timing diagram - master mode

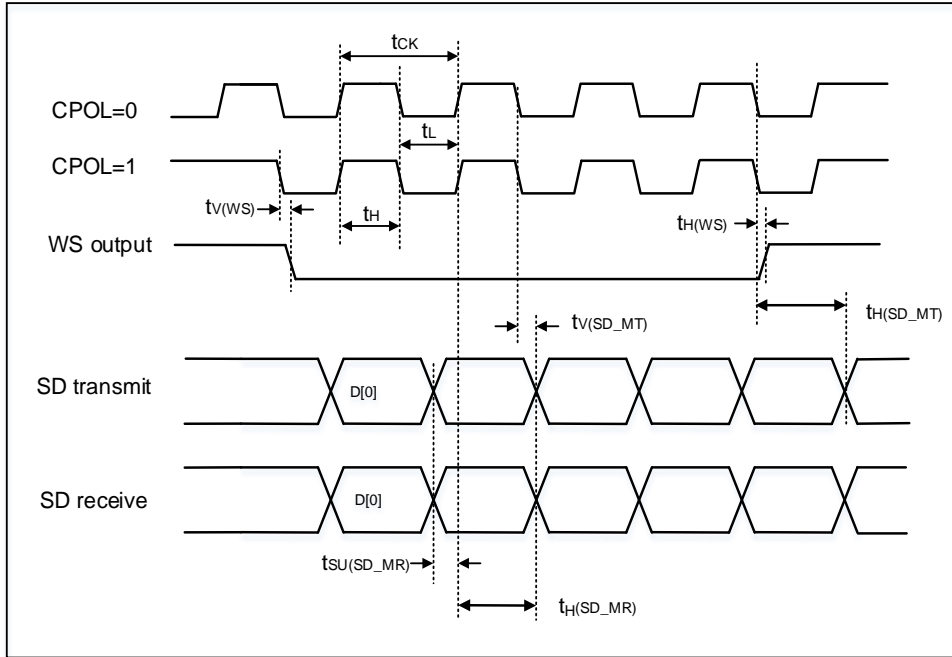
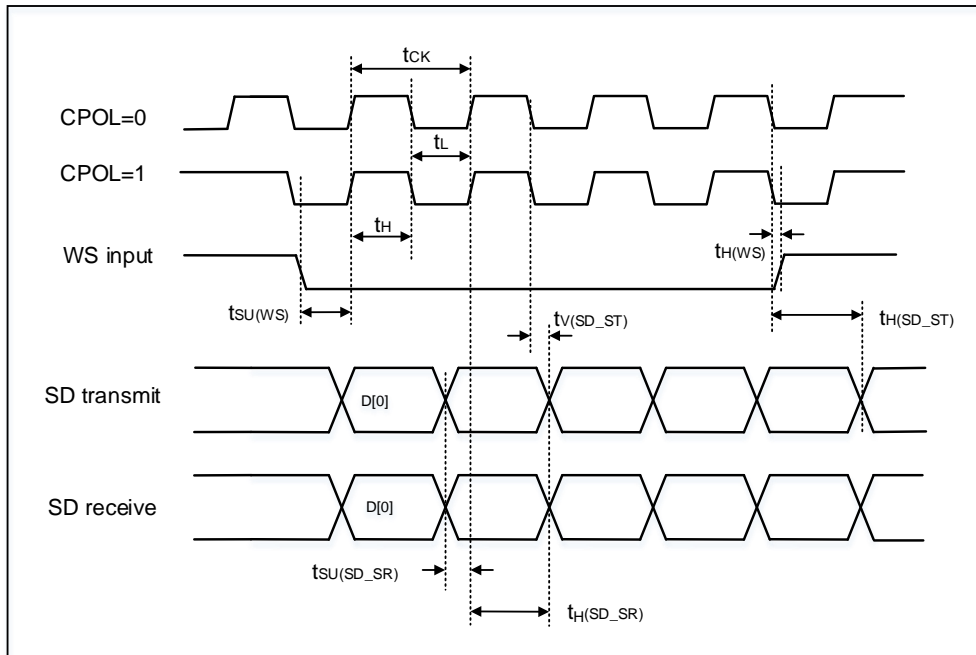

Figure 4-9. I2S timing diagram - slave mode



4.21. USART characteristics

Table 4-43. USART characteristics ⁽¹⁾

Symbol	Parameter	Conditions	Min	Typ	Max	Unit
f _{SCK}	SCK clock frequency	f _{PCLKx} = 180 MHz	—	—	90	MHz
t _{SCK(H)}	SCK clock high time	f _{PCLKx} = 180 MHz	5	—	—	ns
t _{SCK(L)}	SCK clock low time	f _{PCLKx} = 180 MHz	5	—	—	ns

(1) Guaranteed by design, not tested in production.

4.22. CAN characteristics

Refer to [Table 4-25. I/O port DC characteristics ^{\(1\)}](#) for more details on the input/output alternate function characteristics (CANTX and CANRX).

4.23. USBHS characteristics

Table 4-44. USBHS DC electrical characteristics

Symbol	Parameter	Conditions	Min	Typ	Max	Unit	
V _{DD} ⁽²⁾	USB operating voltage	—	3	—	3.63	V	
LS/FS FUNCTIONALITY							
Input levels ⁽¹⁾	V _{DIFS}	Differential input sensitivity(FS/LS)	—	0.2	—	V	
	V _{CMFS}	Differential common mode range(FS/LS)	Includes V _{DI} range	0.8	—		2.5
	V _{ILSE}	Single ended receiver low level input voltage (FS/LS)	—	—	—		0.8
	V _{IHSE}	Single ended receiver high level input voltage (FS/LS)	—	2.0	—		—
Output levels ⁽²⁾	V _{OLFS}	Static output level low(FS/LS)	R _L of 1.0 kΩ to 3.63 V	—	—	0.3	V
	V _{OHFS}	Static output level high(FS/LS)	R _L of 15 kΩ to V _{SS}	2.8	3.3	3.63	
R _{PD} ⁽²⁾	PA11, PA12(USBHS_DM/DP)	V _{IN} = V _{DD}	17	21	25	kΩ	
	PA9(USBHS_VBUS)		0.72	0.9	1.1		
R _{PU} ⁽²⁾	PA11, PA12(USBHS_DM/DP)	V _{IN} = V _{SS}	1.2	1.5	1.8		
	PA9(USBHS_VBUS)		0.24	0.3	0.33		
Z _{HSDRV} ⁽¹⁾	Driver Output Impedance	Steady state drive	40.5	45	49.5	Ω	

HS FUNCTIONALITY							
Input levels ⁽¹⁾	V _{DIHS}	Differential input sensitivity(HS)	—	0.1	—	—	V
	V _{CMHS}	Differential common mode range(HS)	—	-50	—	500	mV
	V _{HSSQ}	HS Squelch Detection Threshold	—	100	—	150	mV
	V _{HSDSC}	HS Disconnect Threshold	—	525	—	625	mV
Output levels ⁽¹⁾	V _{OLHS}	High speed low level output voltage	45Ω load	-10	—	10	mV
	V _{OHHS}	High speed high level output voltage	45Ω load	360	400	440	mV

(1) Guaranteed by design, not tested in production.

(2) Based on characterization, not tested in production.

Table 4-45. USBHS dynamic characteristics⁽¹⁾

Symbol	Parameter	Conditions	Min	Typ	Max	Unit
T _{FR}	Rise time(FS/LS)	CL = 50 pF	4	5	20	ns
T _{HSR}	Differential Rise Time(HS)	—	500	600	—	ps
T _{FF}	Fall time(FS/LS)	CL = 50 pF	4	5	20	ns
T _{HSF}	Differential Fall Time(HS)	—	500	600	—	ps
t _{RFM}	Rise/ fall time matching(FS/LS)	t _R / t _F	90	—	110	%
V _{CRS}	Output signal crossover voltage(FS/LS)	—	1.3	—	2.0	V

(1) Guaranteed by design, not tested in production.

Table 4-46. USBHS Charger Detection characteristics⁽¹⁾

Symbol	Parameter	Conditions	Min	Typ	Max	Unit
V _{DAT_SRC}	Data Source Voltage	—	0.5	—	0.7	V
I _{DP_SRC}	Data Connect Current	—	7	—	13	uA
V _{DAT_REF}	Data Detect Voltage	—	0.25	—	0.4	V

(1) Guaranteed by design, not tested in production.

Table 4-47. USBHS clock timing parameters⁽¹⁾

Symbol	Parameter	Min	Typ	Max	Unit
V _{DD}	USBHS operating voltage	3.0	—	3.63	V
f _{HCLK}	f _{HCLK} value to guarantee proper operation of USBHS interface	30	—	—	MHz
F _{START_8BIT}	Frequency (first transition) 8-bit ± 10%	54	60	66	MHz
F _{STEADY}	Frequency (steady state) ±500 ppm	59.97	60	60.63	MHz
D _{START_8BIT}	Duty cycle (first transition) 8-bit ± 10%	40	50	60	%
D _{STEADY}	Duty cycle (steady state) ±500 ppm	49.975	50	50.025	%

(1) Guaranteed by design, not tested in production.

Table 4-48. USB-ULPI Dynamic characteristics⁽¹⁾

Symbol	Parameter	Min	Typ	Max	Unit
t _{SC}	Control in (ULPI_DIR, ULPI_NXT) setup time	—	—	2	ns
t _{HC}	Control in (ULPI_DIR, ULPI_NXT) hold time	0.5	—	—	ns
t _{SD}	Data in setup time	—	—	2	ns
t _{HD}	Data in hold time	0	—	—	ns

(1) Guaranteed by design, not tested in production.

Figure 4-10. USBFS timings: definition of data signal rise and fall time

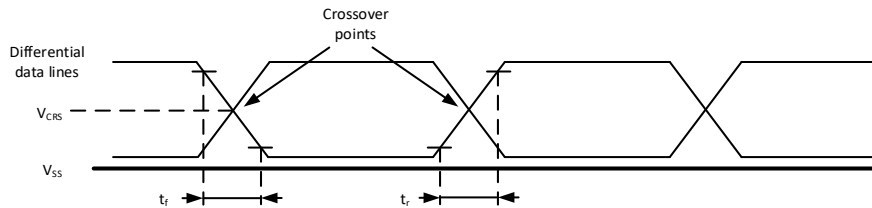

4.24. EXMC characteristics

Table 4-49. Asynchronous non-multiplexed SRAM/PSRAM/NOR read timings ⁽¹⁾⁽²⁾⁽³⁾

Symbol	Parameter	Min	Max	Unit
$t_{w(NE)}$	EXMC_NE low time	27	29	ns
$t_{v(NOENOE)}$	EXMC_NEx low to EXMC_NOE low	0	—	ns
$t_{w(NOENOE)}$	EXMC_NOE low time	27	29	ns
$t_{h(NE_NOENOE)}$	EXMC_NOE high to EXMC_NE high hold time	0	—	ns
$t_{v(A_NE)}$	EXMC_NEx low to EXMC_A valid	0	—	ns
$t_{v(BL_NE)}$	EXMC_NEx low to EXMC_BL valid	0	—	ns
$t_{su(DATA_NE)}$	Data to EXMC_NEx high setup time	21.4	—	ns
$t_{su(DATA_NOENOE)}$	Data to EXMC_NOEx high setup time	21.4	—	ns
$t_{h(DATA_NOENOE)}$	Data hold time after EXMC_NOE high	0	—	ns
$t_{h(DATA_NE)}$	Data hold time after EXMC_NEx high	0	—	ns
$t_{v(NADV_NE)}$	EXMC_NEx low to EXMC_NADV low	0	—	ns
$t_{w(NADV)}$	EXMC_NADV low time	4.6	6.6	ns

(1) $C_L = 30$ pF.

(2) Guaranteed by design, not tested in production.

(3) Based on configure: $f_{HCLK} = 180$ MHz, AddressSetupTime = 0, AddressHoldTime = 1, DataSetupTime = 1.

Table 4-50. Asynchronous non-multiplexed SRAM/PSRAM/NOR write timings ⁽¹⁾⁽²⁾⁽³⁾

Symbol	Parameter	Min	Max	Unit
$t_{w(NE)}$	EXMC_NE low time	15.8	17.8	ns
$t_{v(NWENOE)}$	EXMC_NEx low to EXMC_NWE low	4.6	—	ns
$t_{w(NWENOE)}$	EXMC_NWE low time	4.6	6.6	ns
$t_{h(NE_NWENOE)}$	EXMC_NWE high to EXMC_NE high hold time	4.6	6.6	ns
$t_{v(A_NE)}$	EXMC_NEx low to EXMC_A valid	0	—	ns
$t_{v(NADV_NE)}$	EXMC_NEx low to EXMC_NADV low	0	—	ns
$t_{w(NADV)}$	EXMC_NADV low time	4.6	6.6	ns
$t_{h(AD_NADV)}$	EXMC_AD(address) valid hold time after EXMC_NADV high	10.2	—	ns
$t_{h(A_NWE)}$	Address hold time after EXMC_NWE high	4.6	—	ns
$t_{h(BL_NWE)}$	EXMC_BL hold time after EXMC_NWE high	4.6	—	ns
$t_{v(BL_NE)}$	EXMC_NEx low to EXMC_BL valid	15.8	17.8	ns

$t_{v(DATA_NADV)}$	EXMC_NADV high to DATA valid	4.6	—	ns
$t_{h(DATA_NWE)}$	Data hold time after EXMC_NWE high	4.6	6.6	ns

(1) $C_L = 30$ pF.

(2) Guaranteed by design, not tested in production.

(3) Based on configure: $f_{HCLK} = 180$ MHz, AddressSetupTime = 0, AddressHoldTime = 1, DataSetupTime = 1.

Table 4-51. Asynchronous multiplexed PSRAM/NOR read timings ⁽¹⁾⁽²⁾⁽³⁾

Symbol	Parameter	Min	Max	Unit
$t_{w(NE)}$	EXMC_NE low time	38.2	40.2	ns
$t_{v(NOE_NE)}$	EXMC_NEx low to EXMC_NOE low	15.8	—	ns
$t_{w(NOE)}$	EXMC_NOE low time	21.4	23.4	ns
$t_{h(NE_NOE)}$	EXMC_NOE high to EXMC_NE high hold time	0	—	ns
$t_{v(A_NE)}$	EXMC_NEx low to EXMC_A valid	0	—	ns
$t_{v(A_NOE)}$	Address hold time after EXMC_NOE high	0	—	ns
$t_{v(BL_NE)}$	EXMC_NEx low to EXMC_BL valid	0	—	ns
$t_{h(BL_NOE)}$	EXMC_BL hold time after EXMC_NOE high	0	—	ns
$t_{su(DATA_NE)}$	Data to EXMC_NEx high setup time	22.4	—	ns
$t_{su(DATA_NOE)}$	Data to EXMC_NOEx high setup time	22.4	—	ns
$t_{h(DATA_NOE)}$	Data hold time after EXMC_NOE high	0	—	ns
$t_{h(DATA_NE)}$	Data hold time after EXMC_NEx high	0	—	ns
$t_{v(NADV_NE)}$	EXMC_NEx low to EXMC_NADV low	0	—	ns
$t_{w(NADV)}$	EXMC_NADV low time	4.6	6.6	ns
$T_{h(AD_NADV)}$	EXMC_AD(address) valid hold time after EXMC_NADV high	4.6	6.6	ns

(1) $C_L = 30$ pF.

(2) Guaranteed by design, not tested in production.

(3) Based on configure: $f_{HCLK} = 180$ MHz, AddressSetupTime = 0, AddressHoldTime = 1, DataSetupTime = 1.

Table 4-52. Asynchronous multiplexed PSRAM/NOR write timings ⁽¹⁾⁽²⁾⁽³⁾

Symbol	Parameter	Min	Max	Unit
$t_{w(NE)}$	EXMC_NE low time	27	29	ns
$t_{v(NWE_NE)}$	EXMC_NEx low to EXMC_NWE low	7.3	—	ns
$t_{w(NWE)}$	EXMC_NWE low time	15.8	17.8	ns
$t_{h(NE_NWE)}$	EXMC_NWE high to EXMC_NE high hold time	4.6	—	ns
$t_{v(A_NE)}$	EXMC_NEx low to EXMC_A valid	0	—	ns
$t_{v(NADV_NE)}$	EXMC_NEx low to EXMC_NADV low	0	—	ns
$t_{w(NADV)}$	EXMC_NADV low time	4.6	6.6	ns
$t_{h(AD_NADV)}$	EXMC_AD(address) valid hold time after EXMC_NADV high	4.6	—	ns
$t_{h(A_NWE)}$	Address hold time after EXMC_NWE high	4.6	—	ns
$t_{h(BL_NWE)}$	EXMC_BL hold time after EXMC_NWE high	4.6	—	ns
$t_{v(BL_NE)}$	EXMC_NEx low to EXMC_BL valid	0	—	ns
$t_{v(DATA_NADV)}$	EXMC_NADV high to DATA valid	4.6	—	ns
$t_{h(DATA_NWE)}$	Data hold time after EXMC_NWE high	4.6	—	ns

(1) $C_L = 30$ pF.

(2) Guaranteed by design, not tested in production.

(3) Based on configure: $f_{HCLK} = 180$ MHz, AddressSetupTime = 0, AddressHoldTime = 1, DataSetupTime = 1.

Table 4-53. Synchronous multiplexed PSRAM/NOR read timings ⁽¹⁾⁽²⁾⁽³⁾⁽⁴⁾

Symbol	Parameter	Min	Max	Unit
$t_{w(CLK)}$	EXMC_CLK period	22.4	—	ns
$t_{d(CLKL-NExL)}$	EXMC_CLK low to EXMC_NEx low	0	—	ns
$t_{d(CLKH-NExH)}$	EXMC_CLK high to EXMC_NEx high	10.2	—	ns
$t_{d(CLKL-NADV L)}$	EXMC_CLK low to EXMC_NADV low	0	—	ns
$t_{d(CLKL-NADV H)}$	EXMC_CLK low to EXMC_NADV high	0	—	ns
$t_{d(CLKL-AV)}$	EXMC_CLK low to EXMC_Ax valid	0	—	ns
$t_{d(CLKH-AIV)}$	EXMC_CLK high to EXMC_Ax invalid	10.2	—	ns
$t_{d(CLKL-NOEL)}$	EXMC_CLK low to EXMC_NOE low	0	—	ns
$t_{d(CLKH-NOEH)}$	EXMC_CLK high to EXMC_NOE high	10.2	—	ns
$t_{d(CLKL-ADV)}$	EXMC_CLK low to EXMC_AD valid	0	—	ns
$t_{d(CLKL-ADIV)}$	EXMC_CLK low to EXMC_AD invalid	0	—	ns

(1) $C_L = 30$ pF.

(2) Guaranteed by design, not tested in production.

(3) Based on configure: $f_{HCLK} = 180$ MHz, BurstAccessMode = Enable; Memory Type = PSRAM; WriteBurst = Enable; CLKDivision = 3 (EXMC_CLK is 4 divided by HCLK); Data Latency = 1.

Table 4-54. Synchronous multiplexed PSRAM write timings ⁽¹⁾⁽²⁾⁽³⁾

Symbol	Parameter	Min	Max	Unit
$t_{w(CLK)}$	EXMC_CLK period	22.4	—	ns
$t_{d(CLKL-NExL)}$	EXMC_CLK low to EXMC_NEx low	0	—	ns
$t_{d(CLKH-NExH)}$	EXMC_CLK high to EXMC_NEx high	10.2	—	ns
$t_{d(CLKL-NADV L)}$	EXMC_CLK low to EXMC_NADV low	0	—	ns
$t_{d(CLKL-NADV H)}$	EXMC_CLK low to EXMC_NADV high	0	—	ns
$t_{d(CLKL-AV)}$	EXMC_CLK low to EXMC_Ax valid	0	—	ns
$t_{d(CLKH-AIV)}$	EXMC_CLK high to EXMC_Ax invalid	10.2	—	ns
$t_{d(CLKL-NWEL)}$	EXMC_CLK low to EXMC_NWE low	0	—	ns
$t_{d(CLKH-NWEH)}$	EXMC_CLK high to EXMC_NWE high	10.2	—	ns
$t_{d(CLKL-ADIV)}$	EXMC_CLK low to EXMC_AD invalid	0	—	ns
$t_{d(CLKL-DATA)}$	EXMC_A/D valid data after EXMC_CLK low	0	—	ns
$t_{h(CLKL-NBLH)}$	EXMC_CLK low to EXMC_NBL high	0	—	ns

(1) $C_L = 30$ pF.

(2) Guaranteed by design, not tested in production.

(3) Based on configure: $f_{HCLK} = 180$ MHz, BurstAccessMode = Enable; MemoryType = PSRAM; WriteBurst = Enable; CLKDivision = 3 (EXMC_CLK is 4 divided by HCLK); DataLatency = 1.

Table 4-55. Synchronous non-multiplexed PSRAM/NOR read timings ⁽¹⁾⁽²⁾⁽³⁾

Symbol	Parameter	Min	Max	Unit
$t_{w(\text{CLK})}$	EXMC_CLK period	22.4	—	ns
$t_{d(\text{CLKL-NExL})}$	EXMC_CLK low to EXMC_NEx low	0	—	ns
$t_{d(\text{CLKH-NExH})}$	EXMC_CLK high to EXMC_NEx high	10.2	—	ns
$t_{d(\text{CLKL-NADVl})}$	EXMC_CLK low to EXMC_NADV low	0	—	ns
$t_{d(\text{CLKL-NADVh})}$	EXMC_CLK low to EXMC_NADV high	0	—	ns
$t_{d(\text{CLKL-AV})}$	EXMC_CLK low to EXMC_Ax valid	0	—	ns
$t_{d(\text{CLKH-AIV})}$	EXMC_CLK high to EXMC_Ax invalid	10.2	—	ns
$t_{d(\text{CLKL-NOEL})}$	EXMC_CLK low to EXMC_NOE low	0	—	ns
$t_{d(\text{CLKH-NOEH})}$	EXMC_CLK high to EXMC_NOE high	10.2	—	ns

(1) $C_L = 30$ pF.

(2) Guaranteed by design, not tested in production.

(3) Based on configure: HCLK=180 MHz, BurstAccessMode = Enable; MemoryType = PSRAM; WriteBurst = Enable; CLKDivision = 3 (EXMC_CLK is 4 divided by HCLK); DataLatency = 1.

Table 4-56. Synchronous non-multiplexed PSRAM write timings ⁽¹⁾⁽²⁾⁽³⁾

Symbol	Parameter	Min	Max	Unit
$t_{w(\text{CLK})}$	EXMC_CLK period	22.4	—	ns
$t_{d(\text{CLKL-NExL})}$	EXMC_CLK low to EXMC_NEx low	0	—	ns
$t_{d(\text{CLKH-NExH})}$	EXMC_CLK high to EXMC_NEx high	10.2	—	ns
$t_{d(\text{CLKL-NADVl})}$	EXMC_CLK low to EXMC_NADV low	0	—	ns
$t_{d(\text{CLKL-NADVh})}$	EXMC_CLK low to EXMC_NADV high	0	—	ns
$t_{d(\text{CLKL-AV})}$	EXMC_CLK low to EXMC_Ax valid	0	—	ns
$t_{d(\text{CLKH-AIV})}$	EXMC_CLK high to EXMC_Ax invalid	10.2	—	ns
$t_{d(\text{CLKL-NWEL})}$	EXMC_CLK low to EXMC_NWE low	0	—	ns
$t_{d(\text{CLKH-NWEH})}$	EXMC_CLK high to EXMC_NWE high	10.2	—	ns
$t_{d(\text{CLKL-DATA})}$	EXMC_A/D valid data after EXMC_CLK low	0	—	ns
$t_{h(\text{CLKL-NBLH})}$	EXMC_CLK low to EXMC_NBL high	0	—	ns

(1) $C_L = 30$ pF.

(2) Guaranteed by design, not tested in production.

(3) Based on configure: HCLK = 180 MHz, BurstAccessMode = Enable; MemoryType = PSRAM; WriteBurst = Enable; CLKDivision = 3 (EXMC_CLK is 4 divided by HCLK); DataLatency = 1.

4.25. Serial/Quad Parallel Interface (SQPI) characteristics

Table 4-57. SQPI characteristics

Symbol	Parameter	Min	Typ	Max	Unit
$t_{CLK}^{(2)}$	CLK period	11.0 ⁽⁴⁾	—	—	ns
$t_{CD}^{(2)}$	CLK high level duty for even clock divided	45	50	55	%
	CLK high level duty for odd clock divided	45	—	71	
$t_{KHKL}^{(3)}$	CLK rise or fall time	—	—	3	ns
$t_{CPH}^{(2)}$	CE# high between subsequent burst operations	22.2	—	—	ns
$t_{CEM}^{(2)}$	CE# low pulse width	88.8	—	—	ns
$t_{CSP}^{(2)}$	CE# setup time to CLK rising edge	5.5	—	177.7	ns
$t_{CHD}^{(2)}$	CE# hold time from CLK rising edge	5.5	—	177.7	ns
$t_{SP}^{(2)}$	Setup time to active CLK edge	5.5	—	177.7	ns
$t_{HD}^{(2)}$	Hold time from active CLK edge	5.5	—	177.7	ns
$t_{HZ}^{(2)}$	CE# rise to data output high-Z	—	0	—	ns
$t_{ACK}^{(2)}$	CLK fall to data output valid delay	—	0	—	ns
$t_{KOH}^{(2)}$	Data hold time from CLK falling edge	—	0	—	ns

(1) Based on characterization, not tested in production.

(2) Guaranteed by design, not tested in production.

(3) Output driven mode is 50 MHz. Measured from 10% to 90% of VDD.

(4) This is designed minimal period. The operating minimal clock period is 22.2 ns(45 MHz = 180 MHz/4).

4.26. Super High-resolution Timer (SHRTIMER) characteristics

Table 4-58. SHRTIMER characteristics ⁽¹⁾

Symbol	Parameter	Conditions	Min	Typ	Max	Unit
$f_{SHRTIMER}$	SHRTIMER input clock for DLL	Under T_A conditions	—	180	—	MHz
$t_{SHRTIMER}$			—	5.56	—	ns
$t_{res(SHRTIMER)}$	Timer resolution time	$f_{HPMER} = 180$ MHz	—	86.8	—	ps
$RES_{SHRTIMER}$	Timer resolution	—	—	—	16	bit
t_{DTG}	Dead time generator clock period	—	1/64	—	16	$t_{SHRTIMER}$
		$f_{SHRTIMER} = 180$ MHz	0.0868	—	88.89	ns
$ t_{DTR} / t_{DTF} $	Dead time range (absolute value)	—	—	—	$2^{16}-1$	t_{DTG}
		$f_{SHRTIMER} = 180$ MHz	—	—	5825.41	μ s
f_{CHPFRQ}	Chopper stage clock frequency	—	1/256	—	1/16	$f_{SHRTIMER}$
		$f_{SHRTIMER} = 180$ MHz	0.703	—	11.25	MHz
t_{1STPW}	Chopper first pulse length	—	16	—	256	$t_{SHRTIMER}$
		$f_{SHRTIMER} = 180$ MHz	0.089	—	1.42	μ s

(1) Guaranteed by design, not tested in production.

Table 4-59. SHRTIMER output response to fault protection ⁽¹⁾

Symbol	Parameter	Conditions	Min	Typ	Max ⁽²⁾	Unit
$t_{LAT(DF)}$	Digital fault response latency	Propagation delay from SHRTIMER_FLTx digital input to SHRTIMER_STxCHy output pin	—	—	25	ns
$t_{W(FLT)}$	Minimum fault pulse width	—	11	—	—	
$t_{LAT(AF)}$	Analog fault response latency	Propagation delay from comparator CMPx_IPx input to SHRTIMER_STxCHy output pin	—	—	35	

(1) Guaranteed by design, not tested in production.

(2) Based on characterization, not tested in production.

Table 4-60. SHRTIMER output response to external 1 to 10(Synchronous mode ⁽¹⁾)

Symbol	Parameter	Conditions	Min	Typ	Max ⁽²⁾	Unit
$T_{PROP(SHRTIMER)}$	External event response latency in SHRTIMER	SHRTIMER internal propagation delay ⁽³⁾	5	—	6	$t_{SHRTIMER}^{R(2)}$
$t_{LAT(DEEV)}$	Digital external event response latency	Propagation delay from SHRTIMER_EXEVx digital input to SHRTIMER_STxCHy output pin(30pF load) ⁽³⁾	—	—	48	ns
$t_{W(FLT)}$	Minimum external event pulse width	—	11	—	—	
$t_{LAT(AEEV)}$	Analog external event response latency	Propagation delay from comparator CMPx_IPx input pin to SHRTIMER_STxCHy output pin(30pF load) ⁽³⁾	—	—	60	
$T_{JIT(EEV)}$	External event response jitter	Jitter of the delay from SHRTIMER_EXEVx digital input or CMPx_IPx input pin to SHRTIMER_STxCHy output pin(30pF load)	—	—	1	$t_{SHRTIMER}^{R(2)}$
$T_{JIT(PW)}$	Jitter on output pulse width in response to an external event	—	—	—	0	$t_{SHRTIMER}^{R(2)}$

(1) Guaranteed by design, not tested in production.

(2) Based on characterization, not tested in production.

(3) $t_{SHRTIMER} = 1 / f_{SHRTIMER}$ with $f_{SHRTIMER} = 180$ MHz depending on the clock controller configuration.

(4) This parameter does not take into account latency introduced by GPIO or comparator.

Table 4-61. SHRTIMER synchronization input / output ⁽¹⁾

Symbol	Parameter	Conditions	Min	Typ	Max ⁽²⁾	Unit
$t_{W(SYNCIN)}$	Minimum pulse width on SYNCIN inputs, including SHRTIMER_SCIN	—	2	—	—	$t_{SHRTIMER}$
$t_{LAT(DF)}$	Response time to external synchronization request	—	—	—	1	$t_{SHRTIMER}$
$t_{W(AF)}$	Pulse width on SHRTIMER_SCOUT output	—	—	16	—	$t_{SHRTIMER}$
		$f_{SHRTIMER} = 180 \text{ MHz}$	—	88.89	—	ns

(1) Guaranteed by design, not tested in production.

4.27. TIMER characteristics

Table 4-62. TIMER characteristics ⁽¹⁾

Symbol	Parameter	Conditions	Min	Max	Unit
t_{res}	Timer resolution time	—	1	—	$t_{TIMERxCLK}$
		$f_{TIMERxCLK} = 180 \text{ MHz}$	5.6	—	ns
f_{EXT}	Timer external clock frequency	—	0	$f_{TIMERxCLK}/2$	MHz
		$f_{TIMERxCLK} = 180 \text{ MHz}$	0	90	MHz
RES	Timer resolution	TIMERx (except TIMER1)	—	16	bit
		TIMER1	—	32	
$t_{COUNTER}$	16-bit counter clock period when internal clock is selected	—	1	65536	$t_{TIMERxCLK}$
		$f_{TIMERxCLK} = 180 \text{ MHz}$	0.0056	364.1	μs
	32-bit counter clock period when internal clock is selected (only TIMER1)	—	1	2^{32}	$t_{TIMERxCLK}$
		$f_{TIMERxCLK} = 180 \text{ MHz}$	0.0056	23.86	s
t_{MAX_COUNT}	Maximum possible count (except TIMER1)	—	—	$2^{16} \times 2^{16}$	$t_{TIMERxCLK}$
		$f_{TIMERxCLK} = 180 \text{ MHz}$	—	23.86	s
	Maximum possible count (only TIMER1)	—	—	$2^{16} \times 2^{32}$	$t_{TIMERxCLK}$
		$f_{TIMERxCLK} = 180 \text{ MHz}$	—	$2^{16} \times 23.86$	s

(1) Guaranteed by design, not tested in production.

4.28. WDGT characteristics

Table 4-63. FWDGT min/max timeout period at 40 kHz (IRC40K) ⁽¹⁾

Prescaler divider	PSC[2:0] bits	Min timeout RLD[11:0] = 0x000	Max timeout RLD[11:0] = 0xFFF	Unit
1/4	000	0.025	409.525	ms
1/8	001	0.025	819.025	
1/16	010	0.025	1638.025	
1/32	011	0.025	3276.025	
1/64	100	0.025	6552.025	
1/128	101	0.025	13104.025	
1/256	110 or 111	0.025	26208.025	

(1) Guaranteed by design, not tested in production.

Table 4-64. WWDGT min-max timeout value at 90 MHz (f_{PCLK1}) ⁽¹⁾

Prescaler divider	PSC[1:0]	Min timeout value CNT[6:0] = 0x40	Unit	Max timeout value CNT[6:0] = 0x7F	Unit
1/1	00	45.51	μs	2.91	ms
1/2	01	91.02		5.83	
1/4	10	182.04		11.65	
1/8	11	364.08		23.30	

(1) Guaranteed by design, not tested in production.

4.29. Parameter condition

Unless otherwise specified, all values given for $V_{DD} = V_{DDA} = 3.3\text{ V}$, $T_A = 25\text{ °C}$.

5. Package information

5.1. LQFP144 package outline dimensions

Figure 5-1. LQFP144 package outline

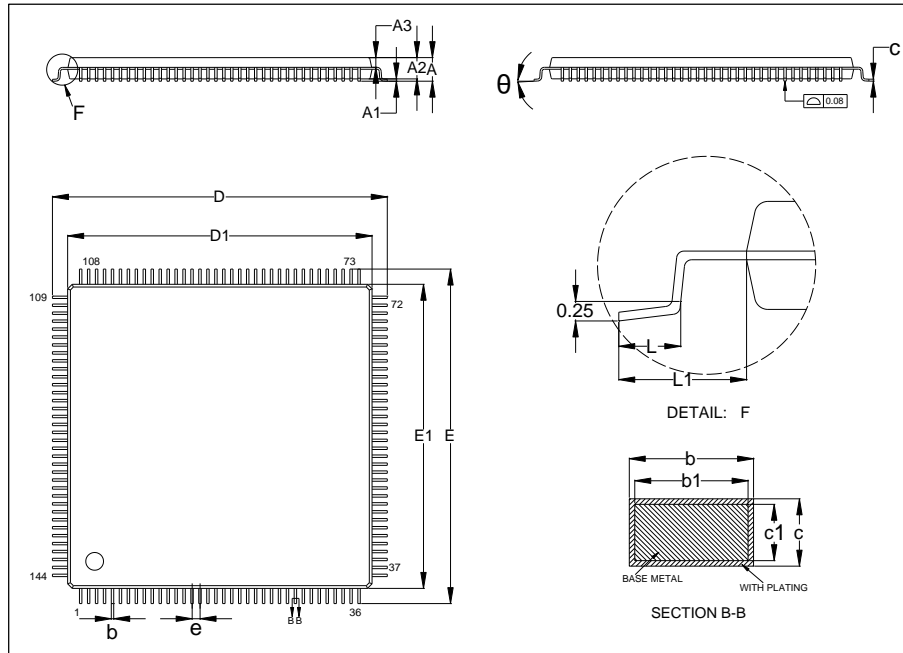
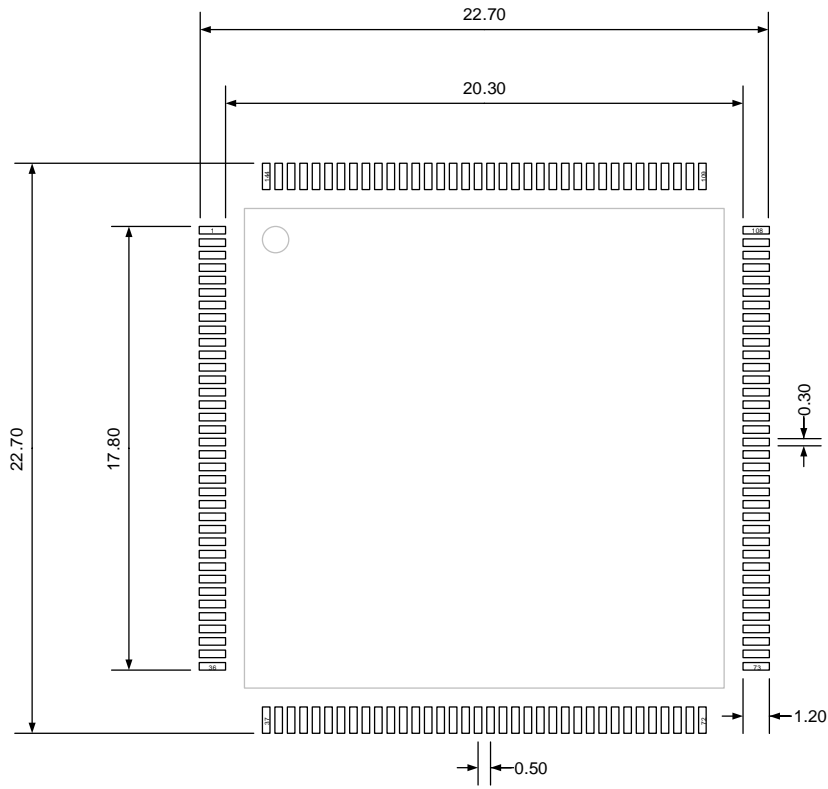

Table 5-1. LQFP144 package dimensions

Symbol	Min	Typ	Max
A	—	—	1.60
A1	0.05	—	0.15
A2	1.35	1.40	1.45
A3	0.59	0.64	0.69
b	0.18	—	0.26
b1	0.17	0.20	0.23
c	0.13	—	0.17
c1	0.12	0.13	0.14
D	21.80	22.00	22.20
D1	19.90	20.00	20.10
E	21.80	22.00	22.20
E1	19.90	20.00	20.10
e	—	0.50	—
L	0.45	—	0.75
L1	—	1.00	—
θ	0°	—	7°

(Original dimensions are in millimeters)

Figure 5-2. LQFP144 recommended footprint



(Original dimensions are in millimeters)

5.2. LQFP100 package outline dimensions

Figure 5-3. LQFP100 package outline

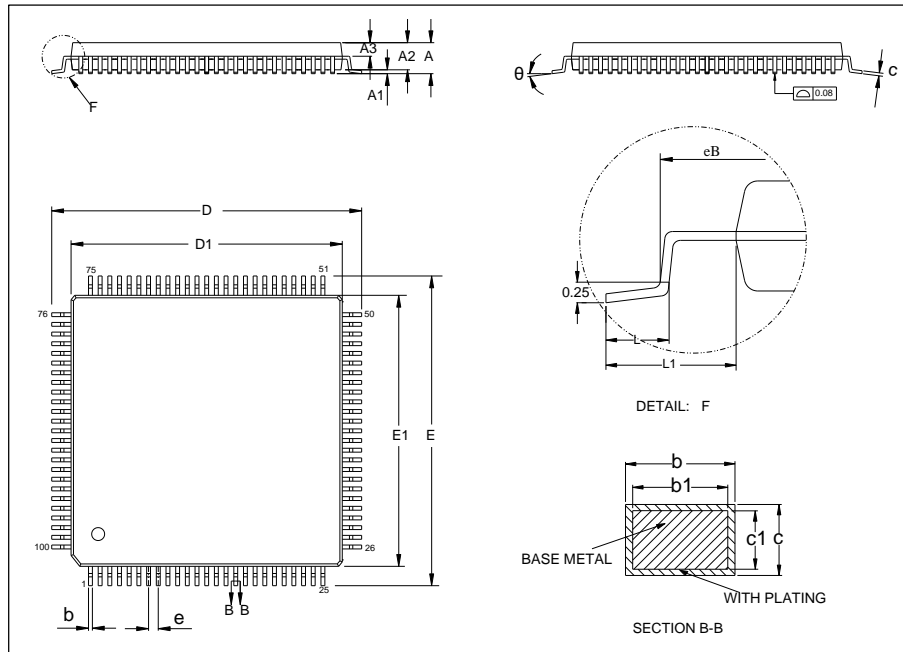
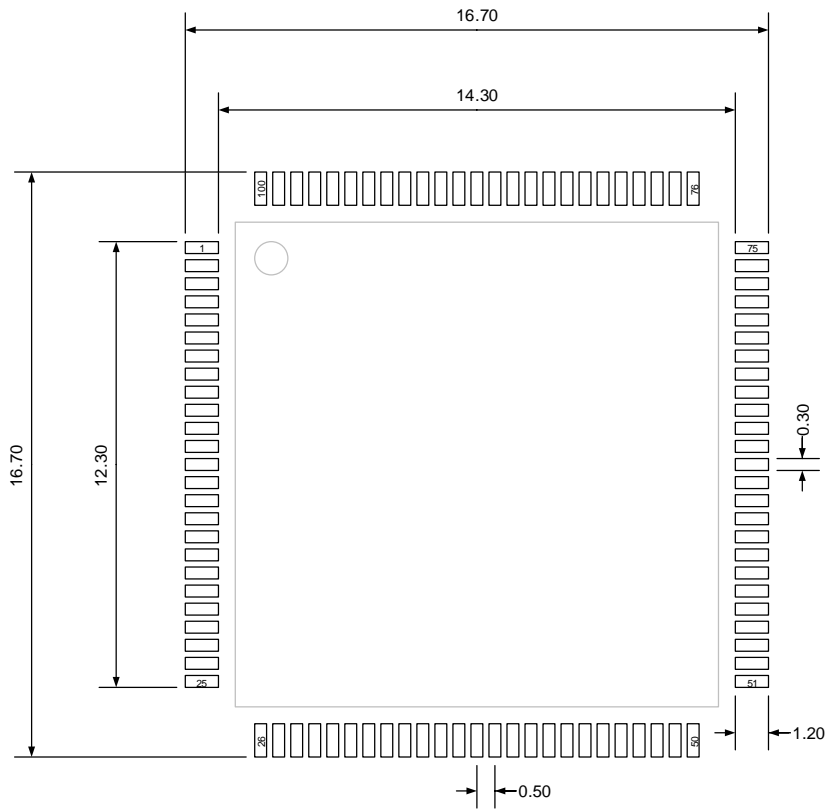

Table 5-2. LQFP100 package dimensions

Symbol	Min	Typ	Max
A	—	—	1.60
A1	0.05	—	0.15
A2	1.35	1.40	1.45
A3	0.59	0.64	0.69
b	0.18	—	0.26
b1	0.17	0.20	0.23
c	0.13	—	0.17
c1	0.12	0.13	0.14
D	15.80	16.00	16.20
D1	13.90	14.00	14.10
E	15.80	16.00	16.20
E1	13.90	14.00	14.10
e	—	0.50	—
eB	15.05	—	15.35
L	0.45	—	0.75
L1	—	1.00	—
θ	0°	—	7°

(Original dimensions are in millimeters)

Figure 5-4. LQFP100 recommended footprint



(Original dimensions are in millimeters)

5.3. Thermal characteristics

Thermal resistance is used to characterize the thermal performance of the package device, which is represented by the Greek letter “ θ ”. For semiconductor devices, thermal resistance represents the steady-state temperature rise of the chip junction due to the heat dissipated on the chip surface.

θ_{JA} : Thermal resistance, junction-to-ambient.

θ_{JB} : Thermal resistance, junction-to-board.

θ_{JC} : Thermal resistance, junction-to-case.

Ψ_{JB} : Thermal characterization parameter, junction-to-board.

Ψ_{JT} : Thermal characterization parameter, junction-to-top center.

$$\theta_{JA}=(T_J-T_A)/P_D \quad (5-1)$$

$$\theta_{JB}=(T_J-T_B)/P_D \quad (5-2)$$

$$\theta_{JC}=(T_J-T_C)/P_D \quad (5-3)$$

Where, T_J = Junction temperature.

T_A = Ambient temperature

T_B = Board temperature

T_C = Case temperature which is monitoring on package surface

P_D = Total power dissipation

θ_{JA} represents the resistance of the heat flows from the heating junction to ambient air. It is an indicator of package heat dissipation capability. Lower θ_{JA} can be considerate as better overall thermal performance. θ_{JA} is generally used to estimate junction temperature.

θ_{JB} is used to measure the heat flow resistance between the chip surface and the PCB board.

θ_{JC} represents the thermal resistance between the chip surface and the package top case. θ_{JC} is mainly used to estimate the heat dissipation of the system (using heat sink or other heat dissipation methods outside the device package).

Table 5-3. Package thermal characteristics⁽¹⁾

Symbol	Condition	Package	Value	Unit
θ_{JA}	Natural convection, 2S2P PCB	LQFP144	48.76	°C/W
		LQFP100	49.18	
θ_{JB}	Cold plate, 2S2P PCB	LQFP144	35.00	°C/W
		LQFP100	22.70	
θ_{JC}	Cold plate, 2S2P PCB	LQFP144	12.03	°C/W
		LQFP100	12.52	
Ψ_{JB}	Natural convection, 2S2P PCB	LQFP144	35.32	°C/W

Symbol	Condition	Package	Value	Unit
		LQFP100	32.85	
Ψ_{JT}	Natural convection, 2S2P PCB	LQFP144	1.86	°C/W
		LQFP100	0.53	

(1) Thermal characteristics are based on simulation, and meet JEDEC specification.

6. Ordering information

Table 6-1. Part ordering code for GD32A508xx devices

Ordering code	Flash (KB)	Package	Package type	Temperature operating range
GD32A508ZET7	512	LQFP144	Green	Automotive -40°C to +105°C
GD32A508VET7	512	LQFP100	Green	Automotive -40°C to +105°C

7. Revision history

Table 7-1. Revision history

Revision No.	Description	Date
1.0	Initial Release	Sep.06, 2024
1.1	1. Chapter 3.14, Respectively added descriptions of the maximum speed for different USART channels.	Dec.27, 2024
1.2	1. Update the Important Notice.	Mar.12, 2025
1.3	<ol style="list-style-type: none"> 1. Update DAC to DAC0 in <u>Figure2-1 block diagram</u>. 2. Changed TIMER characteristics t_{COUNTER}'s unit to 'μs' in <u>Table 4-62 TIMER characteristics</u>. 3. Added V_{CORE} item into <u>Table 4-2. DC operating conditions</u>, the typical value is 1.1V. 4. Added V_{DD} / V_{DDA} / V_{REFP} / V_{REFN} items into <u>Table 4-27 Temperature sensor characteristics</u>. 	Jan.31, 2026

Important Notice

This document is the property of GigaDevice Semiconductor Inc. and its subsidiaries (the "Company"). This document, including any product of the Company described in this document (the "Product"), is owned by the Company according to the laws of the People's Republic of China and other applicable laws. The Company reserves all rights under such laws and no Intellectual Property Rights are transferred (either wholly or partially) or licensed by the Company (either expressly or impliedly) herein. The names and brands of third party referred thereto (if any) are the property of their respective owner and referred to for identification purposes only.

To the maximum extent permitted by applicable law, the Company makes no representations or warranties of any kind, express or implied, with regard to the merchantability and the fitness for a particular purpose of the Product, nor does the Company assume any liability arising out of the application or use of any Product. Any information provided in this document is provided only for reference purposes. It is the sole responsibility of the user of this document to determine whether the Product is suitable and fit for its applications and products planned, and properly design, program, and test the functionality and safety of its applications and products planned using the Product. The Product is designed, developed, and/or manufactured for ordinary business, industrial, personal, and/or household applications only, and the Product is not designed or intended for use in (i) safety critical applications such as weapons systems, nuclear facilities, atomic energy controller, combustion controller, aeronautic or aerospace applications, traffic signal instruments, pollution control or hazardous substance management; (ii) life-support systems, other medical equipment or systems (including life support equipment and surgical implants); (iii) automotive applications or environments, including but not limited to applications for active and passive safety of automobiles (regardless of front market or aftermarket), for example, EPS, braking, ADAS (camera/fusion), EMS, TCU, BMS, BSG, TPMS, Airbag, Suspension, DMS, ICMS, Domain, ESC, DCDC, e-clutch, advanced-lighting, etc.. Automobile herein means a vehicle propelled by a self-contained motor, engine or the like, such as, without limitation, cars, trucks, motorcycles, electric cars, and other transportation devices; and/or (iv) other uses where the failure of the device or the Product can reasonably be expected to result in personal injury, death, or severe property or environmental damage (collectively "Unintended Uses"). Customers shall take any and all actions to ensure the Product meets the applicable laws and regulations. The Company is not liable for, in whole or in part, and customers shall hereby release the Company as well as its suppliers and/or distributors from, any claim, damage, or other liability arising from or related to all Unintended Uses of the Product. Customers shall indemnify and hold the Company, and its officers, employees, subsidiaries, affiliates as well as its suppliers and/or distributors harmless from and against all claims, costs, damages, and other liabilities, including claims for personal injury or death, arising from or related to any Unintended Uses of the Product.

Information in this document is provided solely in connection with the Product. The Company reserves the right to make changes, corrections, modifications or improvements to this document and the Product described herein at any time without notice. The Company shall have no responsibility whatsoever for conflicts or incompatibilities arising from future changes to them. Information in this document supersedes and replaces information previously supplied in any prior versions of this document.